

The Building Bye-Laws (Jersey) 2007

TECHNICAL GUIDANCE DOCUMENT

PART 6 DRAINAGE, SANITATION, HOT WATER SAFETY AND WATER EFFICIENCY

2014
EDITION

Main changes in the 2014 Edition

1. To combine the current approved guidance given in the Approved Document H and the Technical Guidance Document 6, in one single Document.
2. General revisions to reflect changes to British Standards resulting from the move to harmonised European Standards.
3. Updating of guidance to reflect the changes made to the bye-laws that allow on site wastewater treatment systems.
4. Requirements relating to hot water storage amended to limit the temperature of hot water delivered to a bath in a newly created dwelling to 48°C.
5. Guidance added on the use of chemical and composting toilets.
6. New requirement aimed at improving water efficiency in newly constructed dwellings.

Contents

	PAGE		PAGE
Use of guidance	4	Ventilating stacks	26
Technical Guidance Documents	4	Greywater recovery systems	26
Other requirements	4	Other legislation	27
Limitation on requirements	4	Adoption of sewerage facilities	27
Materials and workmanship	4		
Independent Certification Schemes	4	Packaged wastewater treatment works and cesspools – The Requirement 6.2	28
Technical specifications	4		
Foul water drainage – The Requirement 6.1	8	Guidance	29
Guidance	9	Performance	29
Performance	9	Introduction to provisions	29
Introduction to provisions	9	Options	29
Section 1: Sanitary pipework	10	Packaged treatment works	30
Traps	10	Siting	30
Branch discharge pipes	10	Design and construction	30
Discharge stacks	13	Marking	30
Materials for pipes, fittings and joints	14	Drainage fields and drainage mounds	30
Air tightness	15	Siting	30
Alternative approach	15	Ground conditions	31
Section 2: Foul drainage	16	Design and construction	31
Outlets	16	Cesspools	32
Surcharging of drains	16	Siting	32
Layout	16	Design and construction	32
Special protection – rodent control	17	Marking	32
Protection from settlement	17	Greywater and rainwater storage tanks	33
Depth of pipe cover	18	Alternative approach	33
Pipe gradients and sizes	18	Appendix 6.2-A: Maintenance of wastewater treatment systems and cesspools	34
Pumping installations	19	Legislation	34
Materials for pipes and jointing	20	Power to require action	34
Bedding and backfilling	20	Guidance on Maintenance	34
Clearance of blockages	23	Drainage fields and mounds	34
Workmanship	24	Packaged treatment works	34
Testing and inspection	25	Cesspools	34
Alternative approach	25	Rainwater drainage – The Requirement 6.3	35
Appendix 6.1-A: Additional guidance for larger buildings, Greywater systems and other Legislation	26	Guidance	36
Capacity of pipes	26	Performance	36
Traps	26	Introduction to provisions	36
Branch discharge pipes	26		

	PAGE		PAGE
Section 1: Gutters and rainwater pipes	37	Sanitary conveniences and washing facilities – The Requirement 6.4	42
Design rainfall intensities	37	Guidance	43
Gutters	37	Performance	43
Rainwater pipes	37	General	43
Siphonic roof drainage systems	38	Scale of provision and layout in dwellings	43
Eaves drop systems	38	Scale of provision and layout in buildings other than dwellings	44
Rainwater recovery systems	38	Chemical and composting toilets	45
Materials for gutters, rainwater pipes and joints	38	Discharges to drains	45
Alternative approach	38		
Section 2: Surface water drainage	39	Hot water supply and systems – The Requirement 6.5	46
Outlets	39	Guidance	47
Combined systems	39	Performance	47
Design rainfall intensities	39	General	47
Design	39	Design and installation of directly or indirectly heated hot water storage systems	47
Layout	39	Safety devices	49
Depth of pipes	39	Electric water heating	50
Pipe gradients and sizes	39	Solar water heating	50
Materials for pipes and jointing	40	Discharge pipe from safety devices	50
Bedding and backfilling	40	Prevention of excessive temperatures	53
Clearance of blockages	40	Prevention of scalding	53
Workmanship	40	Installation	53
Testing and inspection	40	Commissioning of fixed building services	53
Contaminated runoff	40		
Soakaways and other infiltration drainage systems	40	Water efficiency – The Requirement 6.6	54
Other types of infiltration system	40	Guidance	55
Detention ponds	41	Performance	55
Alternative approach	41	General	55
		Design and Installation	55
		Standards and references	56
		Standards referred to	58
		Other publications referred to	62

	PAGE		PAGE
DIAGRAMS		TABLES	
6.1		6.1	
1. Direct connection of ground floor WC to a drain	10	1. Minimum trap sizes and seal depths	10
2. Branch connection to stacks – crossflow prevention	11	2. Common branch discharge pipes (unventilated)	12
3. Branch connections	12	3. Minimum diameters for discharge stacks	13
4. Branch ventilation pipes	13	4. Materials for sanitary pipework	14
5. Stub stack	14	5. Flow rates from dwellings	19
6. Termination of ventilation stacks or ventilation part of discharge	14	6. Recommended minimum gradients for foul drains	19
7. Pipes penetrating walls	18	7. Materials for below ground gravity drainage	20
8. Pipe runs near buildings	18	8. Limits of cover for class 120 clayware pipes in any width of trench	22
9. Discharge capacities of foul drains running 0.75 proportional depth	18	9. Limits of cover for class M concrete pipes in any width of trench	22
10. Bedding for pipes	21	10. Limits of cover for thermoplastics (nominal ring stiffness SN4) pipes in any width of trench	22
11. Protection for pipes laid at shallow depths (minimum sizes)	23	11. Minimum dimensions for access fittings and inspection chambers	23
12. Joints for concrete encased pipes (minimum sizes)	23	12. Minimum dimensions for manholes	24
6.2		13. Maximum spacing of access points in metres	25
1. Drainage field	31	14. Materials for access points	25
2. Drainage mound	32	A1. Flow rates from dwellings	26
6.3		A2. Flow rates from appliances	26
1. Discharge capacities of rainwater drains running full	39	A3. Minimum trap sizes and seal depths additional to Table 2	26
6.4		6.3	
1. Separation between hand washbasin/WC and food preparation area – single room	44	1. Calculation of drained area	37
2. Separation between hand washbasin/WC and food preparation area – two rooms	44	2. Gutter sizes and outlet sizes	37
6.5		6.5	
1. Typical discharge pipe arrangement	51	1. Sizing of copper discharge pipe 'D2' for common temperature relief valve outlet sizes	52

Use of guidance

TECHNICAL GUIDANCE DOCUMENTS

This document is one of a series that has been approved and issued by the Minister for Planning and Environment for the purpose of providing practical guidance with respect to the requirements of Schedule 2 and Bye-law 7 of the Building Bye-laws (Jersey) 2007.

A list of all Technical Guidance Documents that have been approved and issued by the Planning and Environment Minister for this purpose can be obtained from the department.

Technical Guidance Documents are intended to provide guidance for some of the more common building situations. However, there may well be alternative ways of achieving compliance with the requirements. Thus, there is no obligation to adopt any particular solution contained in a Technical Guidance Document if you prefer to meet the relevant requirement in some other way.

OTHER REQUIREMENTS

The guidance contained in a Technical Guidance Document relates only to the particular requirements of the Bye-laws which the document addresses.

The building work will also have to comply with the requirements of any other relevant parts in Schedule 2 to the Bye-laws. There are Technical Guidance Documents which give guidance on each of the parts of Schedule 2 and on Bye-law 7.

LIMITATION ON REQUIREMENTS

In accordance with Bye-law 8, the requirements in Parts 1 to 7, 10 and 12 (except for requirements 3.6 and 6.2) of the Second Schedule to the Building Byelaws do not require anything to be done except for the purpose of securing reasonable standards of health and safety for persons in or about buildings (and any others who may be affected by buildings or matters connected with buildings).

This is one of the categories of purpose for which Building Bye-laws may be made. Requirements 3.6 and 6.2 are excluded from Bye-law 8 because they deal directly with prevention of the contamination of water. Parts 8 and 9 (which deal, respectively, with access to and use of buildings and resistance to the passage of sound, are excluded from Bye-law 8 because they address the welfare and convenience of building users. Part 11 is excluded from Bye-law 8 because it addresses the conservation of fuel and power. All these matters are amongst the purposes, other than health and safety, that may be addressed by Building Bye-laws.

MATERIALS AND WORKMANSHIP

Any building work which is subject to the requirements imposed by Schedule 2 to the Building Bye-laws should, in accordance with Bye-law 7, be carried out with proper materials and in a workmanlike manner. You may show that you have complied with Bye-law 7 in a number of ways. These include the appropriate use of a product bearing CE marking in accordance with the Construction Products Directive (89/106/EEC) as amended by the CE Marking Directive (93/68/EEC), or a product complying with an appropriate technical specification (as defined in those Directives), a British Standard, or an alternative national technical specification of any state which is a contracting party to the European Economic Area which, in use, is equivalent, or a product covered by a national or European certificate issued by a European Technical Approval issuing body, and the conditions of use are in accordance with the terms of the certificate. You will find further guidance in the Technical Guidance Document supporting Bye-law 7 on materials and workmanship.

INDEPENDENT CERTIFICATION SCHEMES

There are many UK product certification schemes. Such schemes certify compliance with the requirements of a recognised document which is appropriate to the purpose for which the material is to be used. Materials which are not so certified may still conform to a relevant standard.

Many certification bodies which approve such schemes are accredited by UKAS.

TECHNICAL SPECIFICATIONS

Building bye-laws are made for specific purposes including health, safety, welfare, convenience, conservation of fuel and power and prevention of contamination of water. Standards and technical approvals are relevant guidance to the extent that they relate to these considerations. However, they may also address other aspects of performance such as serviceability, or aspects which, although they relate to the purposes listed above, are not covered by the Bye-laws. When a Technical Guidance Document makes reference to a named standard, the relevant version of the standard is the one listed at the end of the publication. However, if this version has been revised or updated by the issuing standards body, the new version should be used as a source of guidance provided it continues to address the relevant requirements of the Bye-laws.

The appropriate use of a product which complies with a European Technical Approval as defined in the Construction Products Directive will meet the relevant requirements. The Department intends to issue periodic amendments to its Technical Guidance Documents to reflect emerging harmonised European Standards. Where a national standard is to be replaced by a harmonised European Standard, there will be a co-existence period during which either standard may be referred to. At the end of the co-existence period the national standard will be withdrawn.

HOW TO USE THIS APPROVED DOCUMENT

In this document the following conventions have been adopted to assist understanding and interpretation:

- a. Texts shown against a blue background are extracts from the Building Bye-laws and set out the legal requirements that relate to compliance with the sanitation, hot water safety and water efficiency requirements of the Building Bye-laws. It should be remembered however that, as noted above, building works must comply with all the other applicable provisions of the Building Bye-laws.
- b. Key terms are defined below and are printed in ***bold italic text***.
- c. Details of technical publications referred to in the text of this document will be given in footnotes and repeated as end notes. A reference to a publication is likely to be made for one of two main reasons. The publication may contain additional or more comprehensive technical detail, which it would be impractical to include in full in this Document but which is needed to fully explain ways of meeting the requirements; or it is a source of more general information. The reason for the reference will be indicated in each case. The reference will be to a specified edition of the document. The Technical Guidance Document may be amended from time to time to include new references or to refer to revised editions where this aids compliance.

Responsibility for compliance

It is important to remember that if you are the person (e.g. designer, builder, installer) carrying out building work to which any requirement of Building Bye-laws applies you have a responsibility to ensure that the work complies with any such requirement. The building owner may also have a responsibility for ensuring compliance with Building Bye-laws requirements and could be served with an enforcement notice in cases of non-compliance.

General guidance

Key terms

The following are key terms used in this document:

Note: Terms shown with * are defined in legislation, either in the Planning and Building (Jersey) Law or the Building Bye-laws 2007, where the definition may be fuller than the definition given here.

***Building** means any permanent or temporary building and retaining walls over 1m high, but not any other kind of structure or erection, and a reference to a building includes a reference to part of a building. This includes dwellings (houses, flats) and public buildings.

***Building work** includes the erection or extension of a **building**, the provision or extension of a **controlled service or fitting** in or in connection with a building, and the **material alteration** of a building, or a controlled service or fitting.

Combined temperature and pressure relief valve means a mechanically operated valve that opens to discharge water when a fixed (factory set) temperature or fixed (factory set) pressure is exceeded.

***Controlled service or fitting** includes a service or fitting subject to Schedule 2 requirements in respect of sanitation, hot water safety, drainage, combustion appliances, fuel storage and conservation of fuel or power.

Direct heating means a method of heating in which the heat source is integral with the hot water vessel. Examples are an electrical immersion heater, or a gas burner with a flue arrangement that passes through the vessel so that the flue transfers heat to the stored water, or the circulation of water from a vessel situated near a burner with a flue arrangement so that the flue transfers heat to the circulating water.

Domestic hot water means water that has been heated for cooking, food preparation, personal washing or cleaning purposes. The term is used irrespective of the type of **building** in which the hot water system is installed.

Earth-closet means a closet having a movable receptacle for the reception of faecal matter and its deodorisation by the use of earth, ashes or chemicals, or by other methods. This will therefore include chemical and composting toilets.

***Exempt buildings and work** means the erection of any building or extension of a kind described in Schedule 1 to the Building Bye-laws 2007; or the carrying out of any work to or in connection with such a building or extension, if after the carrying out of that work it is still a building or extension of a kind described in that Schedule.

Expansion vessel means a vessel to temporarily accommodate the expansion of water from the unvented hot water storage vessel as it is heated.

Greywater is domestic wastewater excluding faecal matter and urine. When appropriately treated this may replace the use of **wholesome water** in

WCs, urinals and garden irrigation.

Harvested rainwater means rainwater harvested from roofs or other suitable surfaces and collected and stored. When appropriately treated, this may replace the use of **wholesome water** in **WCs, urinals**, garden irrigation or washing machines.

Hot water storage system means a vessel for storing:

- heated **wholesome hot water** or **softened wholesome hot water** for subsequent use
- water that is used to heat other water

together with any ancillary safety devices described in paragraphs 1.3 and 1.4 of the guidance given in respect of requirement 6.5 in this Technical Guidance Document and all other applicable operating devices.

Hot water storage system package means a **hot water storage system** having the safety devices described in paragraphs 1.3 to 1.10 of the guidance given in respect of requirement 6.5 of this Technical Guidance Document factory-fitted by the manufacturer, together with a kit containing other applicable devices supplied by the manufacturer to be fitted by the installer.

Hot water storage system unit means a **hot water storage system** having the safety devices described in paragraphs 1.3 to 1.10 of the guidance given in respect of requirement 6.5 of this Technical Guidance Document and all other applicable operating devices factory-fitted by the manufacturer.

Indirect heating means a method of heating stored water through a heat exchanger.

Kitchen means a room or part of a room which contains a **sink** and food preparation facilities

Material alteration means an alteration which results in a **building** or a **controlled service or fitting** not complying with, or being more unsatisfactory than it was before in relation to Schedule 2 requirements in relation to structure, means of warning and escape, internal and external fire spread, fire service access and facilities, and access and use.

Non-self-resetting energy cut-out means a device that will interrupt the supply of heat to a hot water storage vessel when a fixed (factory set) temperature is exceeded. If this protective device is actuated it should only be possible to reset it manually.

Preparation of food means handling, making and cooking of food.

Pressure relief valve means a mechanically operated valve that opens to discharge water when a fixed (factory set) pressure is exceeded.

Primary thermal store means a store of heat energy that can be used to heat **domestic hot water** by means of a heat exchanger. The thermal store can be heated by a variety of heat sources. Primary hot water thermal stores can

be either vented or unvented.

Risk assessment for the purposes of this document means the identification of the hazards associated with a process or activity combined with an assessment of the probability and consequences of each hazard.

***Room for residential purposes** means a room, or a suite of rooms, which is not a dwelling-house or a flat and which is used by one or more persons to live and sleep in, and includes a room in a hostel, a hotel, a boarding house, a hall of residence or a residential home, but does not include a room in a hospital, or other similar establishment, used for patient accommodation.

Sanitary accommodation means a room containing a **WC** or **urinal**, whether or not it also contains other **sanitary appliances**. Sanitary accommodation containing one or more cubicles counts as a single space if there is free circulation of air throughout the space.

Sanitary appliance means **WC, urinal**, bath, shower, washbasin, **sink**, bidet and drinking fountain. It also includes appliances that are not connected to a water supply (e.g. composting toilet) or drain (e.g. waterless **urinal**).

***Sanitary convenience** means closets and **urinals**.

Sink means a receptacle used for holding water (for **preparation of food** or washing up) supplied through a tap and having a wastepipe.

Tundish means a device, installed in the discharge pipe from a valve, that provides an air break allowing discharge to be conducted safely to a place of termination. The tundish also provides a visible indication of a discharge and functions as backflow prevention device.

Temperature relief valve means a mechanically operated valve that opens to discharge water when a fixed (factory set) temperature is exceeded.

Unvented (closed) hot water storage system means a vessel fed with cold water from a supply pipe or dedicated storage cistern (without a vent pipe) and in which water is heated directly or indirectly. Expansion of the water when it is heated is accommodated either internally or externally and the system is fitted with safety devices to prevent water temperatures exceeding 100°C, and other applicable operating devices to control primary flow, prevent backflow, control working pressure and accommodate expansion.

Urinal means an appliance used for reception and disposal of urine.

Vented (open) hot water storage system means a vessel fed with cold water from a dedicated storage cistern. Expansion of the water when it is heated is accommodated through the cold feed pipe. A vent pipe connecting the top of the vessel to a point open to the atmosphere above the cold water storage cistern is provided as a safety device.

***Water-closet (WC)** means a closet that has a separate fixed receptacle connected to a drainage system and separate provision for flushing from a supply of clean water either by

the operation of a mechanism or by automatic action. Water-closets are also referred to as WCs.

Independent schemes of certification and accreditation

Much of the guidance throughout this document is given in terms of performance.

Since the performance of a system, product, component or structure is dependent upon satisfactory site installation, testing and maintenance, independent schemes of certification and accreditation of installers and maintenance firms will provide confidence in the appropriate standard of workmanship being provided.

Confidence that the required level of performance can be achieved will be demonstrated by the use of a system, material, product or structure which is provided under the arrangements of a product conformity certification scheme and an accreditation of installer scheme.

Third party accredited product conformity certification schemes not only provide a means of identifying materials and designs of systems, products and structures which have demonstrated that they reach the requisite performance, but additionally provide confidence that the systems, materials, products and structures are actually provided to the same specification or design as that tested or assessed.

Third party accreditation of installers of systems, materials, products and structures provides a means of ensuring that installations have been conducted by knowledgeable contractors to appropriate standards, thereby increasing the reliability of the anticipated performance.

Many certification bodies that approve such schemes are accredited by the United Kingdom Accreditation Service.

Notice of completion of commissioning

1.1 The Building Bye-laws (bye-law 17 G) require that the person carrying out the work shall give a notice that commissioning has been carried out according to a procedure set out in the relevant technical guidance document.

1.2 The notice of commissioning should normally be given not more than 5 days after the completion of the commissioning work. Where work is carried out by a person registered with a competent person scheme, it must be given not more than 30 days after the completion of work.

1.3 Where the installation of fixed building services which require commissioning is carried out by a person registered with a competent person scheme, the notice of commissioning should be given by that person, at completion of the work, to the person paying for the work.

1.4 Until the Department receives notice of commissioning it is unlikely to be satisfied that Part 6 has been complied with and consequently is unlikely to be able to give a completion certificate.

The Requirement

This Technical Guidance Document, which takes effect on 01 July 2014, deals with the following requirements in the Building Bye-laws (Jersey) 2007, as amended.

<i>Requirement</i>	<i>Limits on application</i>
<p>6.1 Foul water drainage</p> <p>(1) An adequate system of drainage must be provided to carry foul water from appliances within a building to one of the following, listed in order of priority –</p> <ul style="list-style-type: none">(a) a public sewer; or, if that is not reasonably practicable;(b) a private sewer communicating with a public sewer; or, where that is not reasonably practicable;(c) a cesspool or an appropriate packaged wastewater treatment work, the latter being connected to an appropriate drainage field. <p>(2) In sub-paragraph (1) –</p> <ul style="list-style-type: none">(a) ‘foul water’ means waste water that comprises or includes -<ul style="list-style-type: none">(i) waste from a sanitary convenience, bidet or appliance used for washing receptacles for foul waste,(ii) water that has been used for food preparation, cooking or washing, or(iii) trade effluent;(b) ‘packaged wastewater treatment work’ means a wastewater treatment system constructed with minimal site work using prefabricated components, such system being constructed and tested in accordance with standards and specifications in the relevant technical guidance document;(c) ‘drainage field’ means a system of irrigation pipes, either sub-surface or on the surface soil, allowing effluent to percolate into the surrounding soil. <p>(3) For the purposes of sub-paragraph (2)(b) the relevant technical guidance document is one concerning the design and construction requirements for packaged wastewater treatment works.</p>	<p>Sub-paragraph (1) does not apply to the diversion of water that has been used for personal washing or for the washing of clothes, linen or other articles to collection systems for reuse.</p>

Guidance

Performance

In the Minister's view the requirement of 6.1 will be met if a foul water drainage system:

- a. conveys the flow of foul water to a foul water outfall (a foul or combined sewer, an appropriate packaged treatment plant, cesspool or holding tank);
- b. minimises the risk of blockage or leakage;
- c. prevents foul air from the drainage system from entering the building under working conditions;
- d. is ventilated;
- e. is accessible for clearing blockages; and
- f. does not increase the vulnerability of the building to flooding.

Introduction to provisions

0.1 The capacity of the system should be large enough to carry the expected flow at any point.

0.2 The capacity depends on the size and gradient of the pipes. Minimum sizes and gradient limits are given in the text.

0.3 The pipe sizes quoted in this document are nominal sizes used as a numerical designation in convenient round numbers approximately equal to a manufacturer's size. Equivalent pipe sizes for individual pipe standards will be found in the standards listed in Tables 4, 7 and 14.

Section 1: Sanitary pipework

1.1 The provisions in this section are applicable to domestic buildings and small non-domestic buildings. Further guidance on larger buildings is given in Appendix 6.1A. Complex systems in larger buildings should be designed in accordance with BS EN 12056 (see paragraph 1.39).

1.2 The guidance in these provisions is applicable for WCs with major flush volumes of 5 litres or more. Where WCs with major flush volumes less than 5 litres are used, consideration should be given to the increased risk of blockages. Guidance on the design of sanitary pipework suitable for use with WCs with major flush volumes as low as 4 litres can be found in BS EN 12056 (see paragraph 1.39).

Traps

1.3 All points of discharge into the system should be fitted with a trap (e.g. a water seal trap) to prevent foul air from the system entering the building. Under working and test conditions traps should retain a minimum seal of 25mm of water or equivalent.

1.4 Table 1 gives minimum trap sizes and seal depths for the appliances which are most used (for other appliances see Appendix 6.1A paragraph A4).

1.5 Pressure fluctuation – To prevent the water seal from being broken by the pressures which can develop in the system the branch discharge pipes should be designed as described in paragraphs 1.7 to 1.25.

1.6 Access for clearing blockages – If a trap forms part of an appliance the appliance should be removable. All other traps should be fitted directly after the appliance and should be removable or be fitted with a cleaning eye.

Diagram 1 Direct connection of ground floor WC to a drain

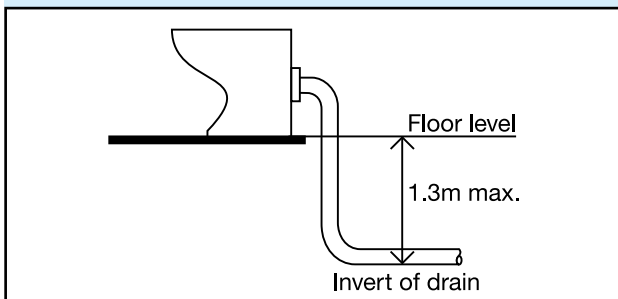

Table 1 Minimum trap sizes and seal depths

Appliance	Diameter of trap (mm)	Depth of seal (mm of water or equivalent)
Washbasin ¹ Bidet	32	75
Bath ² Shower ²	40	50
Food waste disposal unit Urinal bowl Sink Washing machine ² Dishwashing machine ²	40	75
WC pan – outlet <80mm WC pan – outlet >80mm	75 100	50 50

¹ The depth of seal may be reduced to 50mm only with flush grated wastes without plugs on spray tap basins.

² Where these appliances discharge directly to a gully the depth of seal may be reduced to not less than 38mm.

³ Traps used on appliances with flat bottom (trailing waste discharge) and discharging to a gully with a grating may have a reduced water seal of not less than 38mm.

Branch discharge pipes

1.7 Branch pipes should discharge into another branch pipe or a discharge stack unless the appliances discharge to a gully. Gullies are generally at ground floor level, but may be at basement level. Branch pipes should not discharge into open hoppers.

1.8 If the appliances are on the ground floor the pipe(s) may discharge to a stub stack or discharge stack, directly to a drain or (if the pipe carries only wastewater) to a gully. (See paragraphs 1.11 and 1.30.)

1.9 A branch pipe from a ground floor closet should only discharge directly to a drain if the depth from the floor to the drain is 1.3m or less (see Diagram 1).

6.1 SANITARY PIPEWORK

Table 2 Common branch discharge pipes (unventilated)

Appliance	Max. no. to be connected	Max. length of branch pipe (m)	Min. size of pipe (mm)	Gradient limits (mm fall per metre)
WC outlet > 80mm	8	15	100	18 ² to 90
WC outlet < 80mm	1	15	75 ³	18 to 90
Urinal – bowl		3 ¹	50	
Urinal – trough		3 ¹	65	18 to 90
Urinal – slab		3 ¹		
Washbasin or bidet	3	1.7	30	18 to 22
		1.1	30	18 to 44
		0.7	30	18 to 87
		3.0	40	18 to 44
	4	4.0	50	18 to 44

- ¹ Should be as short as possible to prevent deposition.
- ² May be reduced to 9mm on long drain runs where space is restricted, but only if more than one WC is connected.
- ³ Not recommended where disposal of sanitary towels may take place via the WC, as there is an increased risk of blockages.
- ⁴ Slab urinals longer than seven persons should have more than one outlet.

Diagram 3 Branch connections

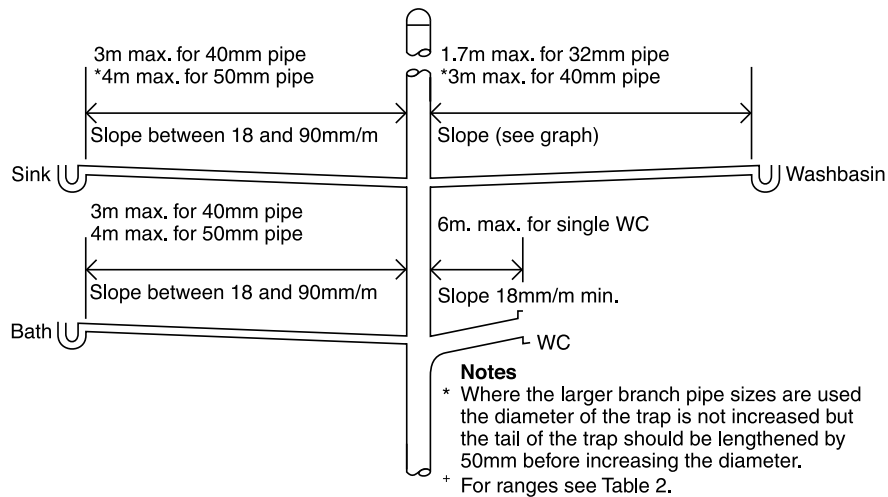

(a) Unvented branch connections to stacks

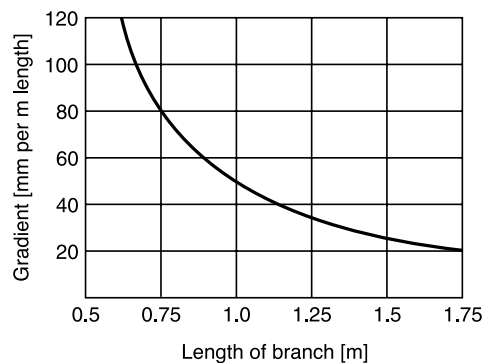

(b) Design curve for 32mm washbasin waste pipes

1.20 If the figures in Table 2 and Diagram 3 are exceeded the branch pipe should be ventilated by a branch ventilating pipe to external air, to a ventilating stack (ventilated branch system) or internally by use of an air admittance valve.

1.21 A separate ventilating stack is only likely to be preferred where the numbers of sanitary appliances and their distance to a discharge stack are large. (See Appendix 6.1A paragraphs A7 to A9.)

1.22 Branch ventilating pipes – should be connected to the discharge pipe within 750mm of the trap and should connect to the ventilating stack or the stack vent, above the highest ‘spillover’ level of the appliances served (see Diagram 4). The ventilating pipe should have a continuous incline from the discharge pipe to the point of connection to the ventilating stack or stack vent.

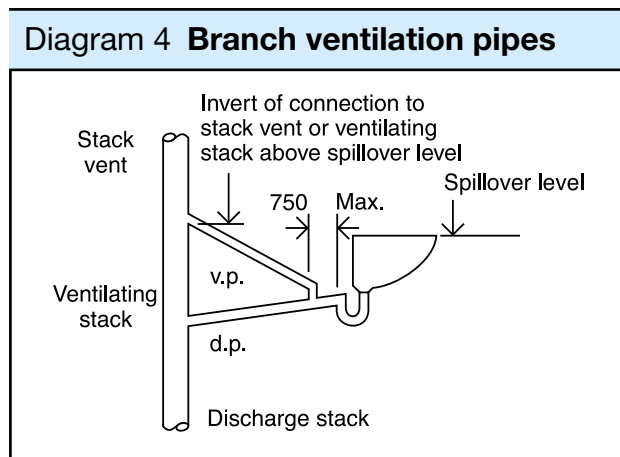

1.23 Branch ventilating pipes which run direct to outside air should finish at least 900mm above any opening into the building nearer than 3m (see Diagram 6 and paragraph 1.31).

1.24 Branch ventilating pipes to branch pipes serving one appliance should be at least 25mm diameter or where the branch is longer than 15m or has more than 5 bends, should be at least 32mm.

1.25 Rodding points should be provided to give access to any lengths of discharge pipe which cannot be reached by removing traps or appliances with internal traps (see paragraph 1.6).

Discharge stacks

1.26 All stacks should discharge to a drain. The bend at the foot of the stack should have as large a radius as possible and at least 200mm at the centre line.

1.27 Offsets in the ‘wet’ portion of a discharge stack should be avoided. If they are unavoidable then in a building of not more than 3 storeys there should be no branch connection within 750mm of the offset. In a building over 3 storeys a ventilation stack may be needed with connections above and below the offset. In buildings over 3 storeys discharge stacks should be located inside the building.

1.28 Sizes of stacks – Stacks should have at least the diameter shown in Table 3 and should not reduce in the direction of flow. Stacks serving urinals should be not less than 50mm, stacks serving closets with outlets less than 80mm should be not less than 75mm and stacks serving closets with outlets greater than 80mm should be not less than 100mm. The internal diameter of the stack should be not less than that of the largest trap or branch discharge pipe. For larger buildings the maximum flow should be checked. (See Appendix 6.1A paragraphs A.1 to A.3.)

Table 3 Minimum diameters for discharge stacks

Stack size (mm)	Max. capacity (litres/sec)
50*	1.2
65*	2.1
75†	3.4
90	5.3
100	7.2

Notes:
 * No WCs.
 † Not more than 1 WC with outlet size <80mm.

1.29 Ventilation of discharge stacks – To prevent water seals in the traps from being lost by pressures which can develop in the system, discharge stacks should be ventilated. Discharge stacks connected to drains liable to surcharging or near an intercepting trap require ventilating pipes of not less than 50mm diameter connected to the base of the stack above the likely flood level.

1.30 Stub stacks – A stub stack may be used if it connects into a ventilated discharge stack or into a ventilated drain not subject to surcharging and no connected water closet has a floor level more than 1.3m and no other branch into the stub stack has a centreline more than 2m to the centre line above the invert of the connection or drain (see Diagram 5).

Diagram 5 Stub stack

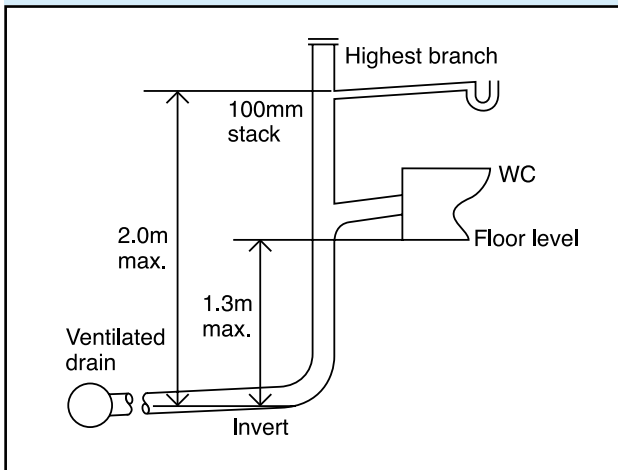

1.31 Ventilating pipes open to outside air should finish at least 900mm above any opening into the building within 3m and should be finished with a wire cage or other perforated cover, fixed to the end of the ventilating pipe, which does not restrict the flow of air (see Diagram 6). In areas where rodent control is a problem (see paragraph 2.22) these should be metallic.

Diagram 6 Termination of ventilation stacks or ventilation part of discharge

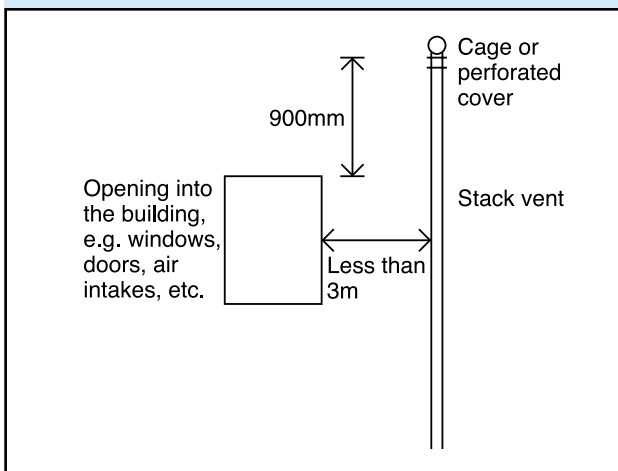

1.32 Sizes of stack ventilation pipes – stack ventilation pipes (the dry part above the highest branch) may be reduced in size in one and two storey houses, but should be not less than 75mm.

1.33 Ventilated discharge stacks may be terminated inside a building when fitted with air admittance valves complying with BS EN 12380:2002. Where these valves are used they should not adversely affect the amount of ventilation necessary for the below ground system which is normally provided by open stacks of the sanitary pipework. Air admittance

valves should be located in areas which have adequate ventilation, should be accessible for maintenance and should be removable to give access for clearance of blockages. Air admittance valves should not be used outside buildings or in dust laden atmospheres. Where there is no open ventilation on a drainage system or through connected drains, alternative arrangements to relieve positive pressures should be considered.

1.34 Access for clearing blockages – rodding points should be provided in discharge stacks to give access to any lengths of pipe which cannot be reached from any other part of the system. All pipes should be reasonably accessible for repair. Rodding points in stacks should be above the spillover level of appliances.

Materials for pipes, fittings and joints

1.35 Any of the materials shown in Table 4 may be used (the references are to British Standard or European Standard Specifications). Where necessary different metals should be separated by non-metallic material to prevent electrolytic corrosion. Care should be taken to ensure continuity of any electrical earth bonding requirements. Pipes should be firmly supported without restricting thermal movement. *Attention is also drawn to the requirement of Part 2 of Schedule 2 to the Building Bye-laws and guidance in the Technical Guidance Document relating to penetration of fire separating elements and fire stopping provisions.*

Table 4 Materials for sanitary pipework

Material	British Standard
Pipes	
Cast iron	BS 416, BS EN 877
Copper	BS EN 1254, BS EN 1057
Galvanised steel	BS 3868
PVC-U	BS EN 1329
Polypropylene (PP)	BS EN 1451
ABS	BS EN 1455
Polyethylene (PE)	BS EN 1519
Styrene copolymer blends (PVC + SAN)	BS EN 1565
PVC-C	BS EN 1566
Traps	
	BS EN 274, BS 3943

Note: Some of these materials may not be suitable for carrying trade effluent or condensate from boilers.

1.36 Sanitary pipework connected to WCs should not allow light to be visible through the pipe wall, as this is believed to encourage damage by rodents.

1.37 Good workmanship is essential. Workmanship should be in accordance with BS 8000 *Workmanship on Building Sites Part 13: Code of practice for above ground drainage*.

Air tightness

1.38 The pipes, fittings and joints should be capable of withstanding an air test of positive pressure of at least 38mm water gauge for at least 3 minutes. Every trap should maintain a water seal of at least 25mm. Smoke testing may be used to identify defects where a water test has failed. Smoke testing is not recommended for PVC-U pipes.

Alternative approach

1.39 The requirement can also be met by following the relevant recommendations of BS EN 12056 *Gravity drainage systems inside buildings*. Relevant clauses are in Part 1: *General and performance requirements*, Clauses 3–6; Part 2 *Sanitary pipework, layout and calculation*, Clauses 3 to 6 and National Annexes NA to NG (System III is traditionally in use in the UK); Part 5 *Installation and testing, instructions for operation, maintenance and use*, Clauses 4–6, 8, 9 and 11. BS EN 12109 *Vacuum Drainage Systems Inside Buildings*.

Section 2: Foul drainage

2.1 This section gives guidance on the construction of underground drains and sewers from buildings to the point of connection to an existing sewer or a cesspool or wastewater treatment system and includes any drains or sewers outside the curtilage of the building.

2.2 Some public sewers may carry foul water and rainwater in the same pipe. Where it is proposed to connect the rainwater drainage system to the public sewer the status of the sewer should be confirmed with the Transport and Technical Services Department and the system should be designed so as to keep the rainwater and foul drainage separate up to a point near the site boundary.

Outlets

2.3 Foul drainage should be connected to a public foul or combined sewer wherever this is reasonably practicable. Where levels do not permit drainage by gravity a pumping installation should be provided (see paragraphs 2.36 to 2.39).

2.4 For larger developments it may be economic to connect to a public sewer even where the sewer is some distance away. Guidance on economic considerations is given in the Planning Department's supplementary guidance advice note relating to the disposal of foul sewage.

2.5 Where it is proposed to connect a drainage system to a public sewer consultation with the Transport and Technical Services Department is required under the Drainage (Jersey) Law 2005.

2.6 Where it is not reasonably practicable to connect to a public sewer, it may be possible to connect to an existing private sewer that connects with a public sewer. The permission of the owner or owners will be required in respect of the private sewer and the Transport and Technical Services Department will need to be consulted about any additional flow to the public sewer. The sewer should be in satisfactory condition and have sufficient capacity to take the additional flows.

2.7 Where none of these options is reasonably practicable, a wastewater treatment system or cesspool should be provided.

Surcharging of drains

2.8 Combined and rainwater sewers are designed to surcharge (i.e. the water level in the manhole rises above the top of the pipe) in heavy rainfall. Some foul sewers also receive rainwater and therefore surcharge. For low-lying sites (where the ground level of the site or the level of a basement is below the ground level at the point where the drainage connects to the public sewer) care should be taken to ensure that the property is not at increased risk of flooding. In all such

cases the Transport and Technical Services Department should be consulted to determine the extent and possible frequency of the likely surcharge.

2.9 For basements containing sanitary appliances, where the risk of flooding due to surcharge of the sewer is considered by the Transport and Technical Services Department to be high, the drainage from the basement should be pumped (see paragraphs 2.36 to 2.40). Where the risk is considered to be low an anti-flooding valve should be installed on the drainage from the basement.

2.10 For other low-lying sites (i.e. not basements) where risk is considered low, sufficient protection for the building may be possible by provision of a gully outside the building at least 75mm below the floor level. This should be positioned so that any flooding from the gully will not damage any buildings. In higher risk areas an anti-flooding valve should be provided, or the drainage system pumped (see paragraph 2.36 to 2.40).

2.11 Anti-flooding valves should preferably be of the double valve type, and should be suitable for foul water and have a manual closure device. They should comply with the requirements of prEN 13564. A single valve should not normally serve more than one building. A notice should be provided inside the building to indicate that the system is drained through such a valve. This notice should also indicate the location of any manual override, and include advice on necessary maintenance.

2.12 All drainage unaffected by surcharge should by-pass the protective measures and discharge by gravity.

Layout

2.13 The layout of the drainage system should be kept simple. Changes of direction and gradient should be minimised and as easy as practicable. Access points should be provided only if blockages could not be cleared without them.

2.14 Connection of drains to other drains or private or public sewers, and of private sewers to public sewers, should be made obliquely, or in the direction of flow.

2.15 Connections should be made using prefabricated components. Where holes are cut in pipes a drilling device should be used to avoid damaging the pipe.

2.16 Where connections made to existing drains or sewers involve removal of pipes and insertion of a junction, repair couplings should be used to ensure a watertight joint and the junction should be carefully packed to avoid differential settlement with adjacent pipes.

2.17 Sewers (serving more than one property) should be kept as far as is practicable away from the point on a building where a future extension is likely (e.g. rear of a house, or side of house where there is room for a side extension). If it is proposed that a new sewer is to be adopted under the provisions of the Drainage (Jersey) Law, no building or structure should be constructed with 5m of the sewer.

2.18 The system should be ventilated by a flow of air. A ventilating pipe should be provided at or near the head of each main drain. An open ventilating pipe (without an air admittance valve) should be provided on any drain fitted with an intercepting trap (particularly on a sealed system), and on any drain subject to surcharge. Ventilated discharge stacks may be used (see paragraphs 1.27 and 1.29). Ventilating pipes should not finish near openings in buildings (see paragraph 1.31).

2.19 Pipes should be laid to even gradients and any change of gradient should be combined with an access point (see paragraph 2.49).

2.20 Pipes should also be laid in straight lines where practicable but may be laid to slight curves if these can still be cleared of blockages. Any bends should be limited to positions in or close to inspection chambers or manholes (see paragraph 2.49) and to the foot of discharge and ventilating stacks. Bends should have as large a radius as practicable.

2.21 Drainage serving kitchens in commercial hot food premises should be fitted with a grease separator complying with BS EN 1825-1:2004 and designed in accordance with BS EN 1825-2:2002 or other effective means of grease removal.

Special protection – rodent control

2.22 Where the site has been previously developed the environmental health officer should be consulted to determine whether any special measures are necessary for control of rodents. Special measures which may be taken include the following.

- a. Sealed drainage – drainage having access covers to the pipework in the inspection chamber instead of an open channel. These should only be used in inspection chambers, where maintenance can be carried out from the surface without personnel entry.
- b. Intercepting traps – These are susceptible to blockage and require frequent maintenance. Intercepting trap stoppers should be of the locking type that can be easily removed from the chamber surface and securely replaced after blockage clearance. It is important that stoppers are replaced after maintenance. These should only be used in inspection chambers where maintenance can be carried out from the surface without personnel entry.

- c. Rodent barriers – a number of rodent barrier devices are used in other countries; these include: enlarged sections on discharge stacks to prevent rats climbing, flexible downward facing fins in the discharge stack, or one way valves in underground drainage.
- d. Metal cages on ventilator stack terminals should also be used to discourage rats from leaving the drainage system (see paragraph 1.31).
- e. Covers and gratings to gullies may be displaced or attacked by rats. Solid plastic covers or metal gratings which can be fixed in place should be used to discourage rats from leaving the system.

Protection from settlement

2.23 A drain may run under a building if at least 100mm of granular or other flexible filling is provided round the pipe. On sites where excessive subsidence is possible additional flexible joints may be advisable or other solutions such as suspended drainage, particularly where the pipe is adjacent to structures or where soil conditions change in the course of the pipe run. Where the crown of the pipe is within 300mm of the underside of the slab, special protection should be provided (see paragraph 2.44).

2.24 At any points where pipes are built into a structure, including an inspection chamber, manhole, footing, ground beam or wall, suitable measures should be taken to prevent damage or misalignment. This may be achieved by either:

- a. building in a length of pipe (as short as possible) with its joints as close as possible to the wall faces (within at most 150mm) and connected on each side of rocker pipes by a length of at most 600mm and flexible joints (see Diagram 7(a)); or
- b. forming an opening to give at least 50mm clearance all round the pipe and the opening masked with rigid sheet material to prevent ingress of fill or vermin. It is important that the void is also filled with a compressible sealant to prevent ingress of gas (see Diagram 7(b)).

2.25 A drain trench should not be excavated lower than the foundations of any building nearby (see Diagram 8) unless either:

- a. where the trench is within 1m of the foundation the trench is filled with concrete up to the lowest level of the foundation; or
- b. where the trench is further than 1m from the building, the trench is filled with concrete to a level below the lowest level for the building equal to the distance from the building, less 150mm.

6.1 FOUL DRAINAGE

Diagram 7 Pipes penetrating walls

(a) Short length of pipe bedded in wall, joints formed within 150mm of either wallface. Adjacent rocker pipes of max. length 600mm with flexible joints

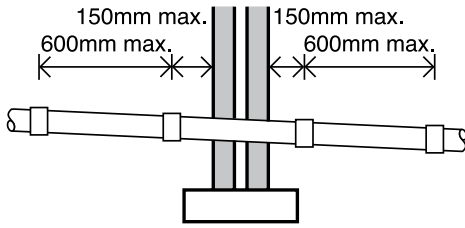

(b) Arch or lintelled opening to give 50mm space all round the pipe

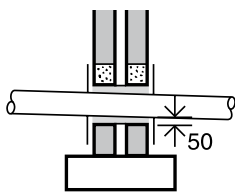

Mask opening both sides with rigid sheet material to prevent entry of fill or vermin

Important Fill void with compressible sealant to prevent entry of gas

Diagram 8 Pipe runs near buildings

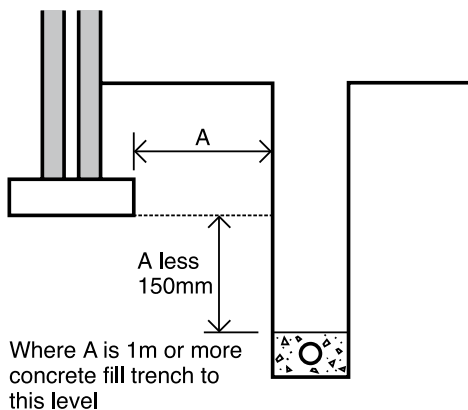
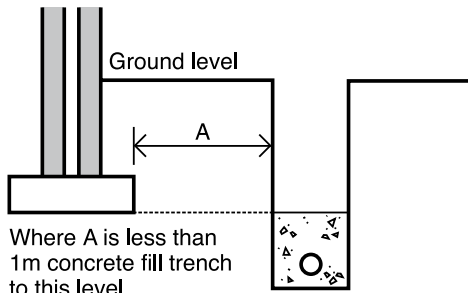

2.26 Where pipes are to be laid on piles or beams or in a common trench, or where the ground may prove unstable particularly where there is a high water table, advice may be found in *TRL A guide to the design loadings for buried rigid pipes*.

Depth of pipe cover

2.27 The depth of cover will usually depend on the levels of the connections to the system, the gradients at which the pipes should be laid and the ground levels.

2.28 Pipes also need to be protected from damage and if the limits of cover are not attainable it may be possible to choose another pipe strength and pipe bedding class combination (Guidance is given in BS EN 1295-1 National Annex NA). Alternatively special protection can be provided (see paragraphs 2.41 to 2.45).

Pipe gradients and sizes

2.29 Drains should have enough capacity to carry the flow. The flow depends on the appliances connected (see paragraphs 0.1–0.3 and Table 5) and the capacity depends on the size and gradient of the pipes (see Diagram 9).

Diagram 9 Discharge capacities of foul drains running 0.75 proportional depth

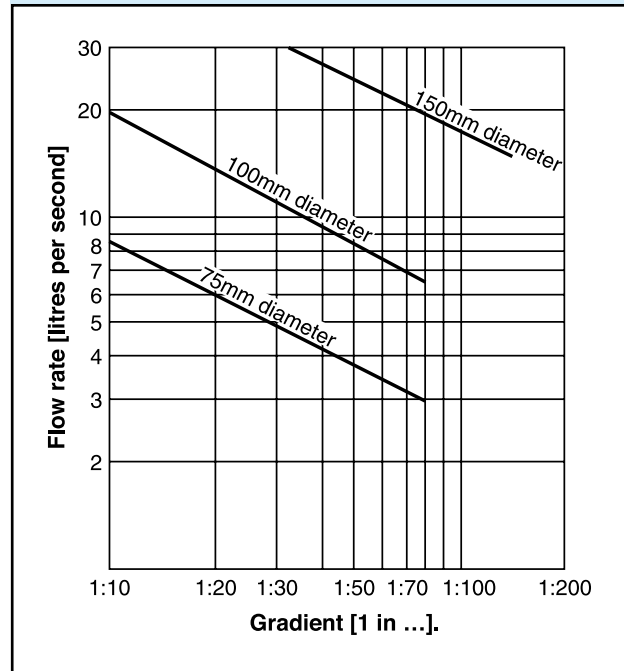

Table 5 Flow rates from dwellings

Number of dwellings	Flow rate (litres/sec)
1	2.5
5	3.5
10	4.1
15	4.6
20	5.1
25	5.4
30	5.8

2.30 Sewers (i.e. a drain serving more than one property) should normally have a minimum diameter of 100mm when serving no more than 10 dwellings. Sewers serving more than 10 dwellings and those which are to be adopted under the provisions of the Drainage (Jersey) Law, should normally have a minimum diameter of 150mm.

2.31 The flow depends on the type, number and grouping of appliances.

2.32 Appliances are seldom in use simultaneously and the minimum drain sizes in normal use are capable of carrying the flow from quite large numbers of appliances. Table 5 shows approximate flow rates resulting from the typical household group of 1 WC, 1 bath, 1 or 2 washbasins, 1 sink and 1 washing machine used for design purposes in BS EN 12056.

2.33 A drain carrying foul water should have an internal diameter of at least 75mm. A drain carrying effluent from a WC or trade effluent should have an internal diameter of at least 100mm.

2.34 Table 6 shows the flattest gradients at which drains should be laid (depending on the flow and the appliances connected to them) and the capacity they will then have (see also paragraphs 0.1–0.3).

Table 6 Recommended minimum gradients for foul drains

Peak flow (litres/sec)	Pipe size (mm)	Minimum gradient (1 in ...)	Maximum capacity (litres/sec)
< 1	75	1:40	4.1
	100	1:40	9.2
> 1	75	1:80	2.8
	100	1:80*	6.3
	150	1:150†	15.0

Notes:

* Minimum of 1 WC

† Minimum of 5 WCs

2.35 Combined systems – the capacity of systems carrying foul water and rainwater should take account of the combined peak flow.

Pumping installations

2.36 Where gravity drainage is impracticable, or protection against flooding due to surcharge in downstream sewers is required, a pumping installation will be needed.

2.37 Package pumping installations are available which are suitable for installation within buildings. Floor mounted units may be particularly suited for installation in basements. These should conform to BS EN 12050. Pumping installations for use inside buildings should be designed in accordance with BS EN 12056-4.

2.38 Package pumping installations suitable for installation outside buildings are also available. Guidance on the design of pumping installations for use outside buildings may be found in BS EN 752-6.

2.39 Where foul water drainage from a building is to be pumped, the effluent receiving chamber should be fitted with dual pumps and sized to contain 24-hour inflow to allow for disruption in service. The chamber should also be fitted with a warning device which alerts the occupants of the building of a failure of any of the pumps. The minimum daily discharge of foul drainage should be taken as 150 litres per head per day for domestic use. For other types of building, the capacity of the receiving chamber should be based on the calculated daily demand of the water intake for the building. Where only a proportion of the foul sewage is to be pumped, then the capacity should be based pro-rata. In all pumped systems the controls should be so arranged to optimise pump operation. Where a pumped installation discharges to a public sewer the flow rate and discharge point must be agreed with the Transport and Technical Services Department.

2.40 Any of the materials shown in Table 7 may be used (the references are to British Standard Specifications). Joints should be appropriate to the material of the pipes. To minimise the effects of any differential settlement pipes should have flexible joints. All joints should remain watertight under working and test conditions and nothing in the pipes, joints or fittings should project into the pipe line or cause an obstruction. Different metals should be separated by non-metallic materials to prevent electrolytic corrosion.

Materials for pipes and jointing

Table 7 Materials for below ground gravity drainage

Material	British Standard
Rigid pipes	
Vitrified clay	BS 65, BS EN 295
Concrete	BS 5911
Grey iron	BS 437
Ductile iron	BS EN 598
Flexible pipes	
UPVC	BS EN 1401+
PP	BS EN 1852+
Structure walled plastic pipes	BS EN 13476
+ Application area code UD should normally be specified	
Note: Some of these materials may not be suitable for conveying trade effluent	

Bedding and backfilling

2.41 The choice of bedding and backfilling depends on the depth at which the pipes are to be laid and the size and strength of the pipes.

2.42 Rigid pipes – The types of bedding and backfilling which should be used for rigid pipes of standard strength laid in a trench of any width are shown in Diagram 10 and Tables 8 and 9. Minimum and maximum depths of cover are also shown for each type.

2.43 Flexible pipes – These will become deformed under load and require support to limit the deformation. The bedding and backfilling should be as shown in Diagram 10. Minimum and maximum depths of cover are also shown in Table 10.

2.44 Where pipes have less than the minimum recommended cover in Table 8, 9 or 10, the pipes should, where necessary, be protected from damage by a reinforced concrete cover slab with a flexible filler and at least 75mm of granular material between the top of the pipe and the underside of the flexible filler below the slabs (see Diagram 11 and paragraphs 2.28, 2.42 and 2.43).

2.45 Where it is necessary to backfill the trench with concrete in order to protect nearby foundations (see paragraph 2.25) movement joints formed with compressible board should be provided at each socket or sleeve joint face (see Diagram 12).

Diagram 10 Bedding for pipes

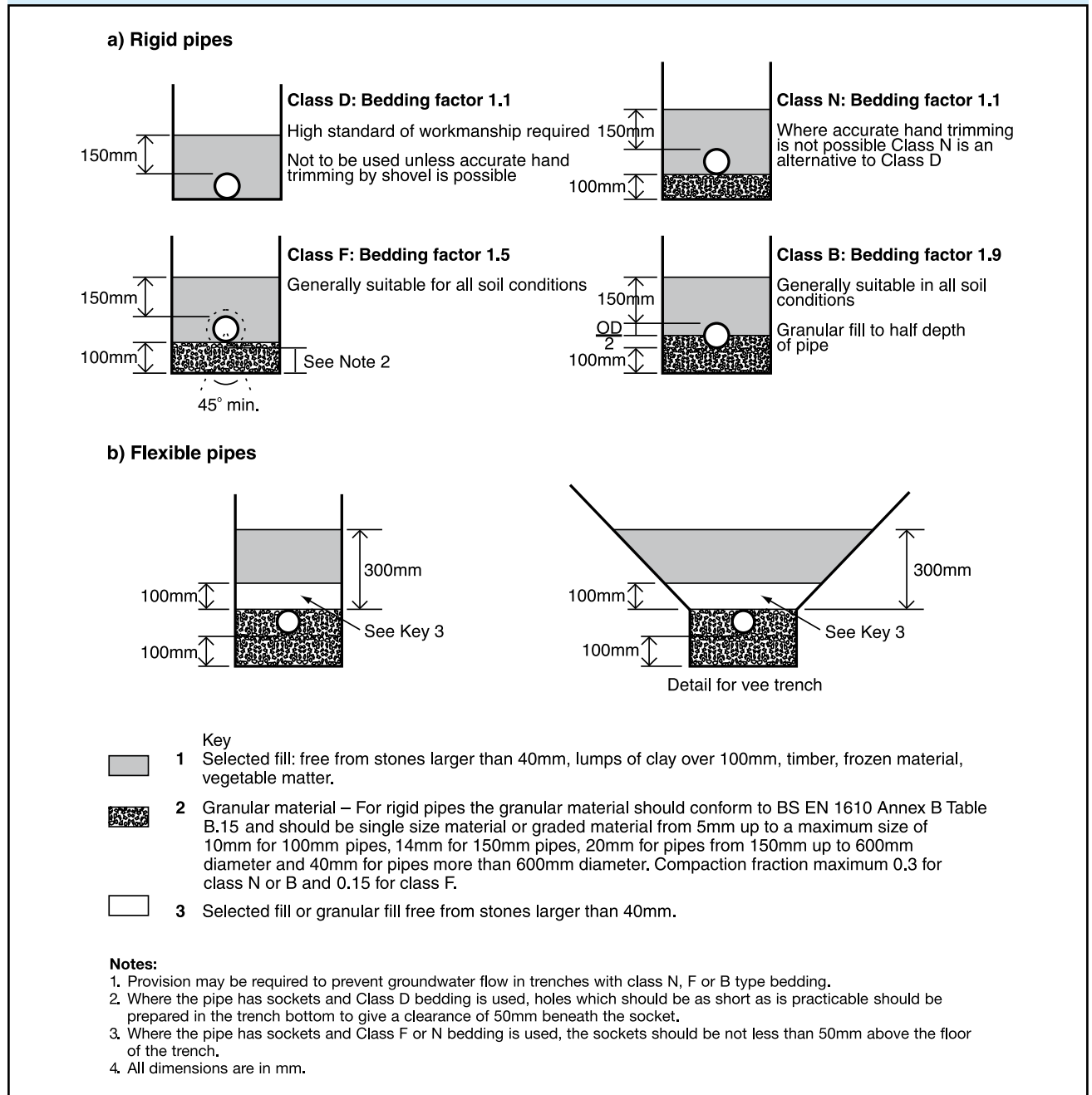

6.1 FOUL DRAINAGE

Table 8 Limits of cover for class 120 clayware pipes in any width of trench

Nominal size	Laid in fields	Laid in light roads	Laid in main roads
100mm	0.6m – 8+m	1.2m – 8+m	1.2m – 8m
225mm	0.6m – 5m	1.2m – 5m	1.2m – 4.5m
400mm	0.6m – 4.5m	1.2m – 4.5m	1.2m – 4m
600mm	0.6m – 4.5m	1.2m – 4.5m	1.2m – 4m

Notes:

1. All pipes assumed to be Class 120 to BS EN 295; other strengths and sizes of pipe are available, consult manufacturers.
2. Bedding assumed to be Class B with bedding factor of 1.9; guidance is available on use of higher bedding factors with clayware pipes.
3. Alternative designs using different pipe strengths and/or bedding types may offer more appropriate or economic options using the procedures set out in BS EN 1295.
4. Minimum depth in roads set to 1.2m irrespective of pipe strength.

Table 9 Limits of cover for class M concrete pipes in any width of trench

Nominal size	Laid in fields	Laid in light roads	Laid in main roads
300mm	0.6m – 3m	1.2m – 3m	1.2m – 2.5m
450mm	0.6m – 3.5m	1.2m – 3.5m	1.2m – 2.5m
600mm	0.6m – 3.5m	1.2m – 3.5m	1.2m – 3m

Notes:

1. All pipes assumed to be Class M to BS 5911; other strengths and sizes of pipe are available, consult manufacturers.
2. Bedding assumed to be Class B with bedding factor of 1.9.
3. Alternative designs using different pipe strengths and/or bedding types may offer more appropriate or economic options using the procedures set out in BS EN 1295.
4. Minimum depth in roads set to 1.2m irrespective of pipe strength.

Table 10 Limits of cover for thermoplastics (nominal ring stiffness SN4) pipes in any width of trench

Nominal size	Laid in fields	Laid in light roads	Laid in main roads
100mm – 300mm	0.6m – 7m	0.9m – 7m	0.9m – 7m

Notes:

1. For drains and sewers less than 1.5m deep and there is a risk of excavation adjacent to the drain and depth, special calculation is necessary, see BS EN 1295.
2. All pipes assumed to be to in accordance with the relevant standard listed in Table 7 with nominal ring stiffness SN4; other strengths and sizes of pipe are available, consult manufacturers.
3. Bedding assumed to be Class S2 with 80% compaction and average soil conditions.
4. Alternative designs using different pipe strengths and/or bedding types may offer more appropriate or economic options using the procedures set out in BS EN 1295.
5. Minimum depth is set to 1.5m irrespective of pipe strength to cover loss of side support from parallel excavations.

Diagram 11 Protection for pipes laid at shallow depths (minimum sizes)

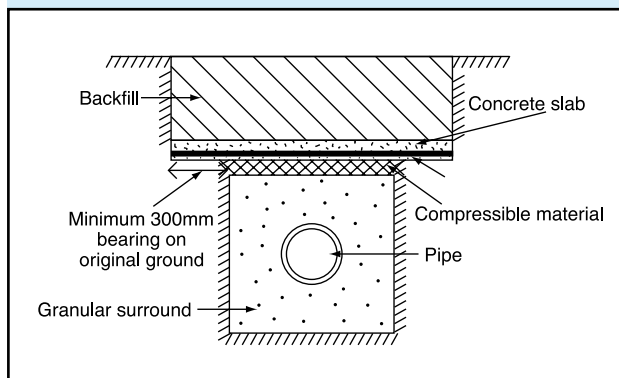
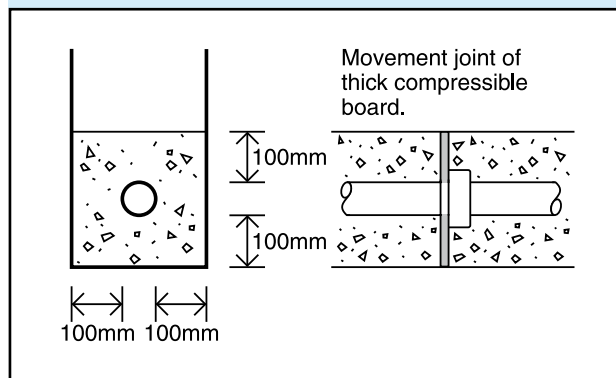

Diagram 12 Joints for concrete encased pipes (minimum sizes)



Clearance of blockages

2.46 Sufficient and suitable access points should be provided for clearing blockages from drain runs which cannot be reached by any other means. The siting, spacing and type of the access points will depend on the layout, depth and size of the runs.

2.47 The provisions described below are for normal methods of rodding (which need not be in the direction of flow) and not mechanical means of clearing.

2.48 Access points should be one of four types. Tables 11 and 12 show the depth at which each type should be used and the recommended dimensions it should have. The dimensions should be increased at junctions if they do not allow enough space for branches. The types are:

- rodding eyes – capped extensions of the pipes;
- access fittings – small chambers on (or an extension of) the pipes but not with an open channel;
- inspection chambers – chambers with working space at ground level;
- manholes – deep chambers with working space at drain level.

2.49 Siting of access points – access should be provided at the following points:

- on or near the head of each drain run, and
- at a bend and at a change of gradient, and
- at a change of pipe size (but see below if it is at a junction), and
- at a junction unless each run can be cleared from an access point (some junctions can only be rodded through from one direction).

Table 11 Minimum dimensions for access fittings and inspection chambers

Type	Depth to invert from cover level (m)	Internal sizes		Cover sizes		
		Length x width (mm x mm)	Circular (mm)	Length x width (mm x mm)	Circular (mm)	
Rodding eye		As drain but min. 100			Same size as pipework ¹	
Access fitting						
small	150 diam.	0.6 or less, except where situated in a chamber	150 x 100	150	150 x 100 ¹	Same size as access fitting
large	225 x 100		225 x 100	225	225 x 100 ¹	
Inspection chamber						
shallow	0.6 or less		225 x 100	190 ²	–	190 ¹
deep	1.2 or less		450 x 450	450	Min. 430 x 430	430
	> 1.2		450 x 450	450	Max. 300 x 300 ³	Access restricted to max. 350 ³

Notes:

- The clear opening may be reduced by 20mm in order to provide proper support for the cover and frame.
- Drains up to 150mm.
- A larger clear opening cover may be used in conjunction with a restricted access. The size is restricted for health and safety reasons to deter entry.

Table 12 Minimum dimensions for manholes

Type	Size of largest pipe (DN)	Min. internal dimensions ¹		Min. clear opening size ¹	
		Rectangular length and width	Circular diameter	Rectangular length and width	Circular diameter
Manhole					
< 1.5m deep to soffit	≤ 150	750 x 675 ⁷	1000 ⁷	750 x 675 ²	na ³
	225	1200 x 675	1200	1200 x 675 ²	
	300	1200 x 750	1200		
	>300	1800 x (DN+450)	The larger of 1800 or (DN+450)		
>1.5m deep to soffit	≤ 225	1200 x 1000	1200	600 x 600	600
	300	1200 x 1075	1200		
	375-450	1350 x 1225	1200		
	>450	1800 x (DN+775)	The larger of 1800 or (DN+775)		
Manhole shaft ⁴					
> 3.0m deep to soffit of pipe	Steps ⁵	1050 x 800	1050	600 x 600	600
	Ladder ⁵	1200 x 800	1200		
	Winch ⁶	900 x 800	900	600 x 600	600

Notes:

1. Larger sizes may be required for manholes on bends or where there are junctions.
2. May be reduced to 600 by 600 where required by highway loading considerations, subject to a safe system of work being specified.
3. Not applicable due to working space needed.
4. Minimum height of chamber in shafted manhole 2m from benching to underside of reducing slab.
5. Min. clear space between ladder or steps and the opposite face of the shaft should be approximately 900mm.
6. Winch only – no steps or ladders, permanent or removable.
7. The minimum size of any manhole serving a sewer (i.e. any drain serving more than one property) should be 1200mm x 675mm rectangular or 1200mm diameter.

2.50 Access should be provided to long runs. The distances between access points depend on the types of access used but should not be more than shown in Table 13 for drains up to and including 300mm.

2.51 Access points to sewers (serving more than one property) should be in places where they are accessible and apparent for use in an emergency. Examples of suitable locations include highways, public open space, unfenced front gardens and shared or unfenced driveways.

2.52 Construction of access points – these should contain the foul water under working and test conditions and resist the entry of groundwater and rainwater. Any of the materials shown in Table 14 may be used.

2.53 Where half round channels are used in inspection chambers and manholes the branches up to and including 150mm diameter should discharge into the channel in the direction of flow at or above the level of the horizontal diameter. A branch with a diameter >150mm should be set with the soffit level with that of the main drain. Where the angle of the branch is more than 45° a three quarter section branch should be used. Channels and branches should be benched up

at least to the top of the outgoing pipe and at a slope of 1 in 12. The benching should be rounded at the channel with a radius of at least 25mm.

2.54 Inspection chambers and manholes should have removable non-ventilating covers of durable material (such as cast iron, cast or pressed steel, precast concrete or plastics) and be of suitable strength. Small lightweight access covers should be secured (for example with screws) to deter unauthorised access (for example by children). Inspection chambers and manholes in buildings should have mechanically fixed airtight covers unless the drain itself has watertight access covers. Manholes deeper than 1m should have metal step irons or fixed ladders.

Workmanship

2.55 Good workmanship is essential. Workmanship should be in accordance with BS 8000 *Workmanship on Building Sites Part 14: Code of practice for below ground drainage*.

2.56 During construction, drains and sewers which are left open should be covered when work is not in progress to prevent entry by rats.

Table 13 Maximum spacing of access points in metres

From	To Access Fitting		To Junction	To Inspection chamber	To Manhole
	Small	Large			
Start of external drain ¹	12	12	–	22	45
Rodding eye	22	22	22	45	45
Access fitting: small 150 diam. and 150 x 100	–	–	12	22	22
large 225 x 100	–	–	22	45	45
Inspection chamber shallow	22	45	22	45	45
Manhole and inspection chamber deep	–	–	–	45	90 ²

Notes:

1. Stack or ground floor appliance
2. May be up to 200 for man-entry size drains and sewers

Table 14 Materials for access points

Material	British Standard
1. Inspection chambers and manholes	
Engineering bricks at least 220mm thick with mortar mix of 1:3 cement–sand ratio	BS 3921
In situ or precast C25 Concrete at least 150mm thick	BS 5911 & BS 8110
Plastics	BS 7158
2. Rodding eyes and access fittings (excluding frames and covers)	as pipes see Table 7 ETA Certificates

2.57 Any drain or sewer should be protected from damage by construction traffic and heavy machinery. Protection may be provided by providing barriers to keep such traffic away from the line of the sewer. Heavy materials should not be stored over drains or sewers.

2.58 Where piling works are being carried out care should be taken to avoid damage to any drain or sewer. The position of the drain or sewer should be established by survey. If the drain or sewer is within 1m of the piling, trial holes should be excavated to establish the exact position of the sewer. The location of any connections should also be established. Piling should not be carried out where the distance from the outside of the sewer to the outside of the pile is less than two times the diameter of the pile.

Testing and inspection

2.59 Water tightness – after laying, including any necessary concrete or other haunching or surrounding and backfilling, gravity drains and private sewers should be tested for water tightness using either an air test or a water test. Information on test requirements is given in paragraphs 2.60 and 2.61 for pipe sizes up to 300mm. For further

information and for larger sizes see BS 8000 Part 14 or BS EN 1610.

2.60 Air test – for pipes up to 300mm diameter, the pipe should be pressurised up to a pressure of 110mm water gauge and held for approximately 5 minutes prior to testing. Following this the pipe should be able to hold an initial 100mm pressure with a maximum loss of head on a manometer of 25mm in a period of 7 minutes.

2.61 Water test – For pipes up to 300mm diameter the system should be filled with water up to a depth of 5m above the lowest invert in the test section and a minimum depth of 1m measured at the highest invert in the test section. This may then be left for a period (one hour is generally sufficient) to condition the pipe. The test pressure should then be maintained for a period of 30 minutes, by topping up the water level as necessary so that it is within 100mm of the required level throughout the test. The losses per square metre of surface area should not exceed 0.15 litres for test lengths with only pipelines or 0.20 litres for test lengths including pipelines and manholes, or 0.40 litres for tests with only manholes and inspection chambers alone (i.e. no pipelines).

2.62 Connectivity – Where separate drainage systems are provided connections should be proven to ensure that they are connected to the correct system.

Alternative approach

2.63 The requirement can also be met by following the relevant recommendations of BS EN 752. The relevant clauses are in Part 3, Part 4 and Part 6. BS EN 752, together with BS EN 1610 and BS EN 1295, contains additional information about design and construction. BS EN 12056 describes the discharge unit method of calculating flows. Also by providing systems meeting the requirements of BS EN 1091 *Vacuum sewerage systems outside buildings*, or BS EN 1671 *Pressure sewerage systems outside buildings*.

Appendix 6.1-A: Additional guidance for larger buildings, Greywater systems and other Legislation

Capacity of pipes

(see paragraph 1.28)

A.1 The flow depends on the type, number and grouping of appliances.

A.2 Appliances are seldom in use simultaneously and the minimum stack sizes in normal use are capable of carrying the flow from quite large numbers of appliances. Table A1 shows approximate flow rates resulting from the typical household group of 1 WC, 1 bath, 1 or 2 washbasins, 1 sink and 1 washing machine used for design purposes in BS EN 12056.

Table A1 Flow rates from dwellings

Number of dwellings	Flow rate (litres/sec)
1	2.5
5	3.5
10	4.1
15	4.6
20	5.1
25	5.4
30	5.8

A.3 Flow rates for other commonly used appliances not covered in Table A1 are shown in Table A2.

Table A2 Flow rates from appliances

Appliance	Flow rate (litres/sec)
Spray tap basin	0.06
Washing machine	0.70
Dishwashing machine	0.25
Urinal (per person)	0.15

Traps

(see paragraph 1.4)

A.4 Minimum trap sizes and seal depths for appliances not listed in Table A2 are shown in Table A3.

Table A3 Minimum trap sizes and seal depths additional to Table 2

Appliance	Diam. of trap (mm)	Depth of seal (mm)
Sanitary towel macerator	40	75
Food waste disposal unit (industrial type)	50	75
Urinal stall (1 to 6 person position)	65	50

Branch discharge pipes

(see paragraph 1.10)

A.5 A branch pipe should not discharge into a stack less than 750mm above the invert of the tail of the bend at the foot of the stack in a multi-storey building up to 5 storeys. Alternatively a branch pipe serving any ground floor appliance may discharge direct to a drain or into its own stack.

A.6 If the building has more than 5 storeys ground floor appliances, unless discharging to a gully or drain, should discharge into their own stack. If the building has more than 20 storeys ground floor appliances, unless discharging to a gully or drain, and first floor appliances should discharge into their own stack.

Ventilating stacks

(see paragraph 1.21)

A.7 A dry stack may provide ventilation for branch ventilation pipes as an alternative to carrying them to outside air or to a ventilated discharge stack (ventilated system).

A.8 Ventilation stacks serving buildings with not more than 10 storeys and containing only dwellings should be at least 32mm diameter (for all other buildings see paragraph 1.29).

A.9 The lower end of a stack may be connected directly to a ventilated discharge stack below the lowest branch discharge pipe connection and above the bend at the foot of the stack or to the crown of the lowest branch discharge pipe connection providing it is ≥ 75 mm diameter.

Greywater recovery systems

A.10 Sanitary pipework and underground drainage used to collect greywater for recovery and re-use within the building should be designed and constructed in accordance with the guidance in this Technical Guidance Document.

A.11 All pipework carrying greywater for re-use should be clearly marked with the word 'GREYWATER' in accordance with Water Regulations Advisory Scheme Information Guidance Note 09-02-05 *Marking and Identification of Pipework for Reclaimed and Grey Water Systems*.

A.12 Further guidance on greywater recovery systems can be found in the Water Regulations Advisory Scheme leaflet No. 09-02-04 *Reclaimed Water Systems. Information about installing, modifying or maintaining reclaimed water systems*.

Other Legislation

A.13 Although the Building Bye-laws do not include requirements for the continuing maintenance or repair of drains and sewers, powers exist under the Planning and Building (Jersey) Law 2002 and the Drainage (Jersey) Law 2005 to require repairs to be made to defective drainage in certain circumstances.

Adoption of sewerage facilities

A.14 Provision exists under the Drainage (Jersey) Law 2005 to allow the Minister for Transport and Technical Services to adopt a sewer as a public sewer.

The Requirement

This Technical Guidance Document, which takes effect on 01 July 2014, deals with the following requirements in the Building Bye-laws (Jersey) 2007, as amended.

<i>Requirement</i>	<i>Limits on application</i>
<p>6.2 Packaged wastewater treatment works and cesspools.</p>	
<p>(1) A cesspool or packaged wastewater treatment work and its drainage field must be sited and constructed so that –</p>	
<p>(a) it is not prejudicial to the health of any person;</p>	
<p>(b) it will not contaminate any watercourse, underground water or water supply;</p>	
<p>(c) there are adequate means of access for emptying and maintenance; and</p>	
<p>(d) where relevant, it will function to a sufficient standard for the protection of health in the event of a power failure.</p>	
<p>(2) A cesspool, or packaged wastewater treatment work that is part of a wastewater treatment system must be –</p>	
<p>(a) of adequate capacity;</p>	
<p>(b) so constructed that it is impermeable to liquids; and</p>	
<p>(c) adequately ventilated.</p>	
<p>(3) Where a foul water drainage system from a building discharges to a cesspool, or packaged wastewater treatment work, a durable notice must be affixed in a suitable place in the building containing information on any continuing maintenance required to avoid risks to health.</p>	
<p>(4) In this paragraph “packaged wastewater treatment work” and “drainage field” have the same meaning as in requirement 6.1.</p>	

Guidance

Performance

In the Minister's view the requirements of 6.2 will be met if:

- a. wastewater treatment systems:
 - i. have sufficient capacity to enable breakdown and settlement of solid matter in the wastewater from the buildings;
 - ii. are sited and constructed so as to prevent overloading of the receiving water.
- b. cesspools have sufficient capacity to store the foul water from the building until they are emptied;
- c. wastewater treatment systems and cesspools are sited and constructed so as not to:
 - i. be prejudicial to health or a nuisance;
 - ii. adversely affect water sources or resources;
 - iii. pollute controlled waters;
 - iv. be in an area where there is a risk of flooding.
- d. wastewater treatment systems and cesspools are constructed and sited so as to:
 - i. have adequate ventilation;
 - ii. prevent leakage of the contents and ingress of subsoil water.
- e. having regard to water table levels at any time of the year and rising groundwater levels, drainage fields are sited and constructed so as to:
 - i. avoid overloading of the soakage capacity and
 - ii. provide adequately for the availability of an aerated layer in the soil at all times.
- f. a notice giving information as to the nature and frequency of maintenance required for the cesspool or wastewater treatment system to continue to function satisfactorily is displayed within each of the buildings.

Introduction to provisions

0.1 A wastewater treatment system should be connected to an appropriate drainage field.

0.2 Paragraphs 1.1 to 1.48 give guidance only on the general principles relating to capacity, siting and ventilation of cesspools and wastewater treatment systems.

Options

1.1 The use of non-mains foul drainage, such as wastewater treatment systems or cesspools, should only be considered where connection to mains drainage is not practicable (see Requirement 6.1).

1.2 Packaged treatment works – This term is applied to a range of systems engineered to treat a given hydraulic and organic load using prefabricated components which can be installed with minimal site work. They use a number of processes which are different in detail, all treat effluent to a higher standard than septic tank systems.

1.3 Packaged treatment works with some form of secondary treatment will normally be acceptable for newly constructed dwellings that cannot connect to the public sewer. Appropriate forms of secondary treatment for use with packaged treatment works (drainage fields or drainage mounds) are described in paragraphs 1.4 to 1.7 below.

1.4 Drainage fields typically consist of a system of sub-surface irrigation pipes which allow the effluent to percolate into the surrounding soil. Biological treatment takes place naturally in the aerated layers of soil.

1.5 Drainage fields should be used to provide secondary treatment in conjunction with packaged treatment works. They may be used where the subsoil is sufficiently free-draining and the site is not prone to flooding or waterlogging at any time of year.

1.6 Drainage mounds are essentially drainage fields placed above the natural surface of the ground providing an aerated layer of soil to treat the discharge.

1.7 Drainage mounds may be used where the subsoil is occasionally waterlogged, but where drainage fields would otherwise be suitable.

1.8 Cesspools – A cesspool is a watertight tank, installed underground, for the storage of sewage. No treatment is involved.

Packaged treatment works

Siting

1.9 Wastewater treatment plants should be sited so as not to impair the stability of any building with the discharge complying with paragraph 1.16. Wastewater treatment plants which are sited within 7m of any habitable parts of a building should be fitted with sealed access covers and be vented at a point more than 7m from any habitable part of the building.

Design and construction

1.10 Where the wastewater plant needs to be maintained using a tanker, it should be sited within 30m of a vehicle access provided that the invert level of the plant is no more than 3m below the level of the vehicle access. This distance should be reduced on a pro rata basis to 15m for plants with an invert level of 6m below vehicle access level. Wastewater treatment systems with an invert level greater than 6m below the level of vehicle access should not be used. There should be a clear route for a hose to empty and clean the plant without it being a hazard to the building occupants, or being taken through a dwelling or place of work.

1.11 In the case of new building and material change of use situations packaged treatment works should be type-tested in accordance with BS EN 12566 -3:2005 or otherwise tested by a notified body, and shown to have a treatment efficiency of at least 20mg/l BOD, 30mg/l suspended solids and 20mg/l ammonia.

1.12 For small scale development, for example, the extension of an existing dwelling to form one additional bedroom, a septic tank conversion kit capable of achieving the treatment efficiency given in paragraph 1.11 above, may be used as an alternative to packaged treatment works complying with BS EN 12566-3:2005.

1.13 If the packaged treatment works requires power to operate it should be able to adequately function without power for up to 6 hours or have an uninterruptable power supply.

Marking

1.14 A notice should be fixed within the building describing the necessary maintenance. An example of such wording is:

‘The foul drainage system from this property discharges to a packaged treatment works. Maintenance is required <insert frequency> and should be carried out by the owner in accordance with the manufacturer’s instructions. The outlet of the works should be inspected regularly to ensure the effluent is free-flowing and clear. The owner is legally responsible to ensure that the system does not cause pollution, a health hazard or a nuisance.’

Drainage fields and drainage mounds

1.15 Paragraphs 1.16 to 1.33 give guidance on design and construction of drainage fields and drainage mounds to provide secondary treatment to the discharge from a package treatment plant.

Siting

1.16 A drainage field or mound serving a wastewater treatment plant should be located:

- a. at least 10m from any watercourse or permeable drain;
- b. at least 50m from the point of abstraction of any groundwater supply;
- c. at least 15m from any building;
- d. sufficiently far from any other drainage fields, drainage mounds or soakaways so that the overall soakage capacity of the ground is not exceeded.

1.17 The disposal area should be downslope of groundwater sources.

1.18 No water supply pipes or underground services other than those required by the disposal system itself should be located within the disposal area.

1.19 No access roads, driveways or paved areas should be located within the disposal area.

Ground conditions

1.20 Well drained and well aerated subsoils are usually brown, yellow or reddish in colour. Examples of subsoils with good percolation characteristics are sand, gravel, chalk, sandy loam and clay loam. It is important that the percolation characteristics are suitable in both summer and winter conditions. Poorly drained or saturated subsoils are often grey or blue in colour. Brown and grey mottling usually indicates periodic saturation. Examples of subsoils with poor percolation characteristics are sandy clay, silty clay and clay.

1.21 A preliminary assessment should be carried out including consultation with the Environment Department to determine the suitability of the site. The natural vegetation on the site should also give an indication of its suitability for a drainage field.

1.22 A trial hole should be dug to determine the position of the standing groundwater table. The trial hole should be a minimum of 1m² in area and 2m deep, or a minimum of 1.5m below the invert of the proposed drainage field pipework. The groundwater table should not rise to within 1m of the invert level of the proposed effluent distribution pipes. If the test is carried out in summer, the likely winter groundwater levels should be considered. A percolation test should then be carried out to assess the further suitability of the proposed area.

1.23 Percolation test method – A hole 300mm square should be excavated to a depth 300mm below the proposed invert level of the effluent distribution pipe. Where deep drains are necessary the hole should conform to this shape at the bottom, but may be enlarged above the 300mm level to enable safe excavation to be carried out. Where deep excavations are necessary a modified test procedure may be adopted using a 300mm earth auger. Bore the test hole vertically to the appropriate depth taking care to remove all loose debris.

1.24 Fill the 300mm square section of the hole to a depth of at least 300mm with water and allow it to seep away overnight.

1.25 Next day, refill the test section with water to a depth of at least 300mm and observe the time, in seconds, for the water to seep away from 75% full to 25% full level (i.e. a depth of 150mm). Divide this time by 150. The answer gives the average time in seconds (V_p) required for the water to drop 1mm.

1.26 The test should be carried out at least three times with at least two trial holes. The average figure from the tests should be taken. The test should not be carried out during abnormal weather conditions such as heavy rain, severe frost or drought.

1.27 Drainage field disposal should only be used when percolation tests indicate average values of V_p of between 12 and 100 and the preliminary site assessment report and trial hole tests have been favourable. This minimum value ensures that untreated effluent cannot percolate too rapidly into groundwater. Where V_p is outside these limits effective treatment is unlikely to take place in a drainage field.

Design and construction

1.28 Drainage mounds (see Diagram 2) can be used in conjunction with domestic waste water treatment plants. The system should be designed and constructed in accordance with the recommendations of BR 478 – Mound filter systems for the treatment of domestic wastewater¹.

1.29 Drainage fields (see Diagram 1) should be constructed following the guidance in Paragraphs 1.30 to 1.33 using perforated pipe, laid in trenches of a uniform gradient which should be not steeper than 1:200.

1.30 Pipes should be laid on a 300mm layer of clean shingle or broken stone graded between 20mm and 50mm.

Diagram 1 Drainage field

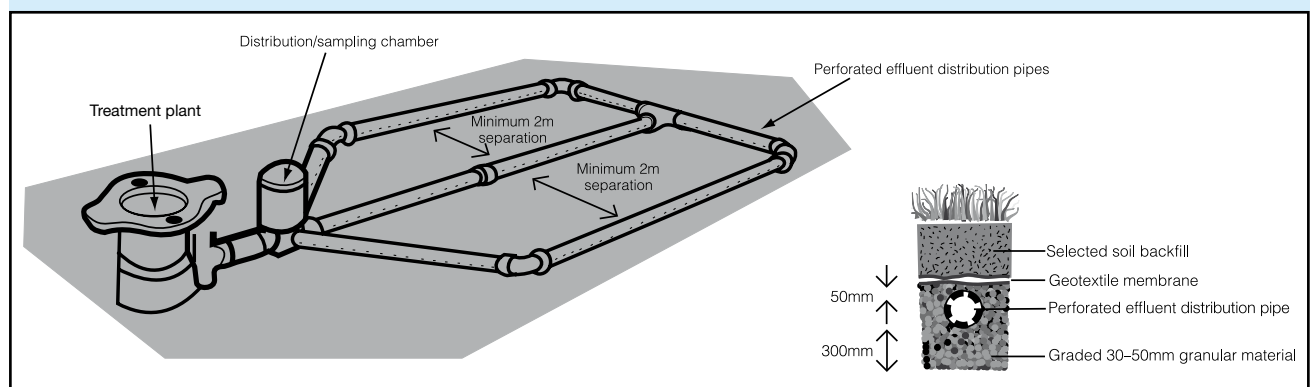

¹ BR478 Mound Filter Systems For the Treatment of Domestic Wastewater: BRE, 2005.

Diagram 2 Example of a Drainage Mound

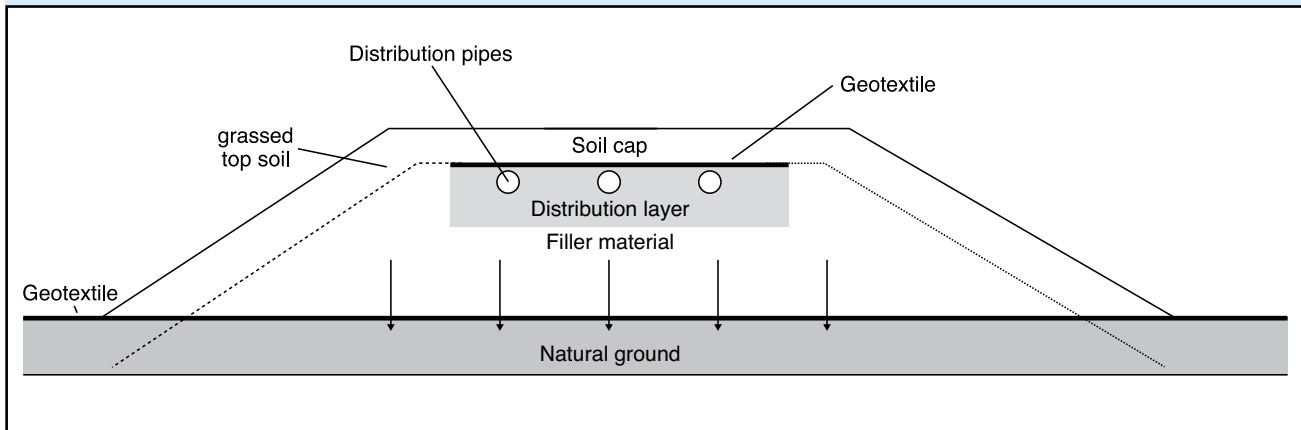

1.31 Trenches should be filled to a level 50mm above the pipe and covered with a layer of geotextile to prevent the entry of silt. The remainder of the trench can be filled with soil; the distribution pipes should be laid at a minimum depth of 500mm below the surface.

Drainage trenches should be from 300mm to 900mm wide, with areas of undisturbed ground 2m wide being maintained between parallel trenches (see Diagram 1).

1.32 An inspection chamber should be installed between the treatment plant and the drainage field.

1.33 Drainage fields should be set out as a continuous loop fed from the inspection chamber (see Diagram 1). To calculate the floor area of the drainage field (A_t in m^2), the following formula should be used:

$A_t = p \times V_p \times 0.20$ for package treatment plants

$A_t = p \times V_p \times 0.25$ for existing septic tanks

where p is the number of persons served by the tank, V_p is the percolation value (secs/mm) obtained as described in paragraphs 1.23–1.27.

Cesspools

Siting

1.34 The site of the cesspool should preferably be on ground sloping away from and sited lower than any existing building in the immediate vicinity.

1.35 Cesspools should be sited so as not to impair the stability of any building.

1.36 Cesspools should be sited within 30m of a vehicle access provided that the invert level of the tank is no more than 3m below the level of the vehicle access. This distance should be reduced on a pro rata basis to 15m for plants with an invert level of 6m below vehicle access level. Cesspools with an invert level greater than 6m below the level of vehicle access should not be used. There should be a clear route for a hose to empty and clean the Cesspool without it being a hazard to the building occupants, or being taken through a dwelling or place of work.

Design and construction

1.37 Cesspools should be provided with access for emptying and cleaning. Access covers should be of durable quality having regard to the corrosive nature of the tank contents. The access should be lockable or otherwise engineered to prevent personnel entry.

1.38 Cesspools should have no openings except for the inlet, access for emptying and ventilation. Cesspools which are sited within 7m of any habitable parts of a building should be fitted with sealed access covers and be vented at a point more than 7m from any habitable part of the building.

1.39 Cesspools should prevent leakage of the contents and ingress of subsoil water and should be ventilated.

1.40 Cesspools should have a capacity below the level of the inlet of at least 18,000 litres ($18m^3$), and be fitted with a warning device which alerts the occupants of the building when the cesspool is 75% full. Where the foul water from a dwelling discharges to a cesspool, a separate cesspool should be provided for each dwelling.

1.41 Factory-made cesspools are available in glass reinforced plastics, polyethylene or steel and should meet the relevant requirements of BS EN 12566-1. Particular care is necessary in ensuring stability of these tanks.

1.42 Cesspools may be constructed in brickwork or concrete, roofed with heavy concrete slabs. Brickwork should be of engineering bricks and be at least 220mm thick. The mortar should be a mix of 1:3 cement–sand ratio. In situ concrete should be at least 150mm thick of C/25/P mix (see BS 5328).

1.43 The inlet of a cesspool should be provided with access for inspection (see Requirement 6.1 Section 2).

Marking

1.44 A notice should be fixed within the building describing the necessary maintenance. An example of such wording is:

'The foul drainage system from this property is served by a cesspool. The system should be emptied approximately every <insert design emptying frequency> by a licensed contractor and inspected fortnightly for overflow. If the cesspool does not fill within the estimated emptying period, the tank should be checked for leakage. The owner is legally responsible to ensure that the system does not cause pollution, a health hazard or a nuisance.'

Greywater and rainwater storage tanks

1.45 Paragraphs 1.46 to 1.47 give guidance on tanks for the storage of greywater or rainwater for re-use within the building. It does not apply to water butts used for the storage of rainwater for garden use.

1.46 Greywater and rainwater harvesting tanks should:

- a. prevent leakage of the contents and ingress of subsoil water, and should be ventilated;
- b. have an anti-backflow device on any overflow connected to a drain or sewer to prevent contamination of the stored greywater or rainwater in the event of surcharge in the drain or sewer;
- c. be provided with access for emptying and cleaning. Access covers should be of durable quality having regard to the corrosive nature of the tank contents. The access should be lockable or otherwise engineered to prevent personnel entry.

Note: Overflows from greywater systems should discharge to a foul sewerage system, and overflows from rainwater tanks should discharge to a soakaway or some other adequate infiltration system.

1.47 Further guidance on systems for greywater and rainwater re-use can be found in the Water Regulations Advisory Scheme leaflet No. 09-02-04. *Reclaimed Water Systems. Information about installing, modifying or maintaining reclaimed water systems.*

Alternative Approach

1.48 The requirement can also be met by following the relevant recommendations of BS 6297:2007 + A1:2008.

Appendix 6.2-A: Maintenance of wastewater treatment systems and cesspools

Legislation

A.1 The Department has powers to ensure that wastewater treatment systems or cesspools are adequately maintained.

Power to require action

A.2 Under Article 85 (Power to require action to be taken in respect of drainage nuisance) of the Planning and Building (Jersey) Law, the Minister may serve a notice requiring measures to eliminate danger to health or a nuisance where it appears to him that drainage or lack of drainage is a danger to health or is a nuisance.

GUIDANCE ON MAINTENANCE

A.3 Paragraphs A.4 to A.9 give guidance on the appropriate maintenance of wastewater treatment systems and cesspools.

Drainage fields and mounds

A.4 The drainage field/mound should be checked on a monthly basis to ensure that it is not waterlogged and that the effluent is not backing up towards the waste water treatment system.

Packaged treatment works

A.5 The outlet of the works should be inspected regularly. The effluent should be free-flowing and clear.

A.6 Maintenance will vary depending on the type of plant; regular maintenance and inspection should be carried out in accordance with the manufacturer's instructions.

Cesspools

A.7 Cesspools should be inspected fortnightly for overflow and emptied as required.

A.8 Typically they require emptying on a monthly basis by a licensed contractor.

A.9 Emptying frequencies may be estimated by assuming a filling rate of 150 litres per person per day. If the cesspool does not fill within the estimated period, the tank should be checked for leakage.

The Requirement

This Technical Guidance Document, which takes effect on 01 July 2014, deals with the following requirements in the Building Bye-laws (Jersey) 2007, as amended.

<i>Requirement</i>	<i>Limits on application</i>
<p>6.3 Rainwater drainage</p> <p>(1) Adequate provision shall be made for rainwater to be carried from the roof of the building.</p> <p>(2) Rainwater from a system provided pursuant to subparagraph (1) shall discharge to one of the following, listed in order of priority:</p> <ul style="list-style-type: none"> (a) an adequate soakaway or some other adequate infiltration system; or, where that is not reasonably practicable, (b) a watercourse; or, where that is not reasonably practicable, (c) a sewer. 	<p>Requirement 6.3 (2) does not apply to the gathering of rainwater for re-use.</p>

Guidance

Performance

In the Minister's view the requirements of 6.3 will be met if:

- a. rainwater from roofs is carried away from the surface either by a drainage system or by other means;
- b. a rainwater drainage system:
 - i. carries the flow of rainwater from the roof to an outfall (a soakaway, a watercourse, a surface water or a combined sewer),
 - ii. minimises the risk of blockage or leakage,
 - iii. is accessible for clearing blockages.
- c. rainwater soaking into the ground is distributed sufficiently so that it does not damage the foundations of the proposed building or any adjacent structure.

Introduction to provisions

0.1 There are no provisions in this document for draining the rainfall on roofs with overall areas of 6m² or less including balconies unless they receive a flow from a rainwater pipe serving larger areas.

0.2 The capacity of the drainage system should be large enough to carry the expected flow at any point in the system.

0.3 The flow depends on the area to be drained and the intensity of the rainfall.

0.4 The capacity depends on the size and gradient of the gutters and pipes. Capacities and minimum sizes are given in the text.

0.5 Rainwater or surface water should not be discharged to a cesspool or waste water treatment plant.

0.6 Rainwater or surface water soakaways should be positioned at least 5m from any building.

0.7 Rainwater or surface water should not discharge to a Public or Private foul sewer without the agreement of the Transport and Technical Services Department.

Section 1: Gutters and rainwater pipes

Design rainfall intensities

1.1 Design rainfall intensities of 0.021 litres/second/m² may be assumed for normal situations.

1.2 Where the design incorporates valley gutters, parapet gutters, siphonic or drainage systems from flat roofs, and where over-topping of these systems would have particularly high consequences such as water entering the building, wetting of insulation or other dampness the design should be carried out in accordance with BS EN 12056 (see paragraph 1.17).

Gutters

1.3 The flow into a gutter depends on the area of surface being drained and whether the surface is flat or pitched (and, if it is pitched, on the angle of pitch). Table 1 shows a way of allowing for the pitch by working out an effective area.

Table 1 Calculation of drained area

Type of surface	Effective design area
1 Flat roof	plan area of relevant portion
2 Pitched roof at 30° Pitched roof at 45° Pitched roof at 60°	plan area of portion x 1.29 plan area of portion x 1.50 plan area of portion x 1.87
3 Pitched roof over 70° or any wall	elevational area x 0.5

1.4 Table 2 shows the largest effective area which should be drained into the gutter sizes which are most often used. These sizes are for a gutter which is laid level, half round in section with a sharp edged outlet at only one end and where the distance from a stop end to the outlet is not more than 50 times the water depth. At greater distances the capacity of the gutter should be reduced. The Table shows the smallest size of outlet which should be used with the gutter.

1.5 Where the outlet is not at the end, the gutter should be of the size appropriate to the larger of the areas draining into it. Where there are two end outlets they may be up to 100 times the depth of flow apart.

Table 2 Gutter sizes and outlet sizes

Max. effective roof area (m ²)	Gutter size (mm diam.)	Outlet size (mm diam.)	Flow capacity (litres/sec)
6.0	–	–	–
18.0	75	50	0.38
37.0	100	63	0.78
53.0	115	63	1.11
65.0	125	75	1.37
103.0	150	89	2.16

Note: Refers to nominal half round eaves gutters laid level with outlets at one end sharp edged. Round edged outlets allow smaller downpipe sizes.

1.6 Gutters should be laid with any fall towards the nearest outlet. Where there is a fall or the gutter has a section which gives it larger capacity than a half-round gutter or the outlet is round edged it may be possible to reduce the size of the gutter and pipe. Paragraph 1.17 gives a reference to some detailed recommendations which make reductions possible.

1.7 Gutters should also be laid so that any overflow in excess of the design capacity, caused by conditions such as above normal rainfall, will be discharged clear of the building, reducing the risk of overspilling of rainwater into the building or structural overload. On flat roofs, valley gutter, and parapet gutters, additional outlets may be necessary.

Rainwater pipes

1.8 Rainwater pipes should discharge into a drain or gully but may discharge to another gutter or onto another surface if it is drained. Any rainwater pipe which discharges into a combined system should do so through a trap (see Requirement 6.1, Section 1, Paragraph 1.3).

1.9 Where a rainwater pipe discharges onto a lower roof or paved area, a pipe shoe should be fitted to divert water away from the building. Where rainwater from a roof with an effective area greater than 25m² discharges through a single downpipe onto a lower roof, a distributor pipe should be fitted to the shoe to ensure that the flow width at the receiving gutter is sufficient so that it does not over-top the gutter.

6.3 GUTTERS AND RAINWATER PIPES

1.10 The size of a rainwater pipe should be at least the size of the outlet from the gutter. A down pipe which serves more than one gutter should have an area at least as large as the largest of the contributing outlets and should be of sufficient size to take the flow from the whole contributing area.

Siphonic roof drainage systems

1.11 Siphonic roof drainage systems should be designed in accordance with BS EN 12056-3 (see paragraph 1.17) and should take particular account of the following:

- a. The need to take account of surcharge in the downstream drainage system as this can reduce the flow in the downpipe.
- b. For long gutters the time taken for the system to prime the siphonic action may be excessive. Overflow arrangements should be provided to prevent gutters from over-topping.

1.12 Further information on the design of siphonic drainage systems can be found in Hydraulics Research Ltd Report SR 463 *Performance of Syphonic Drainage Systems for Roof Gutters*.

Eaves drop systems

1.13 Eaves drop systems allow rainwater from roofs to drop freely to the ground. Where these are used, they should be designed taking into account the following:

- a. the protection of the fabric of the building from ingress of water, caused by water splashing on the external walls;
- b. the need to prevent water from entering doorways and windows;
- c. the need to protect persons using doorways, etc. from falling water;
- d. the need to protect persons and the fabric of the building from rainwater as it hits the ground by splashing, for example by provision of a gravel layer or angled concrete apron deflecting the water away from the building;
- e. the protection of foundations from concentrated discharges such as those from valleys or valley gutters or from excessive flows due to large roofs (i.e. where the area of roof per unit length of eaves is high).

Rainwater recovery systems

1.14 Rainwater drainage systems used to collect water for re-use within the building (rainwater recovery systems) should take account of the following:

- a. storage tanks should comply with requirement 6.2 (see Requirement 6.2 paragraphs 1.45 to 1.47);
- b. pipework, washouts and valves should be clearly identified on marker plates (see Water Regulations Advisory Scheme Information Guidance Note 09-02-05 *Marking and Identification of Pipework for Reclaimed and Grey Water Systems*).

1.15 Further guidance on rainwater recovery systems can be found in the Water Regulations Advisory Scheme leaflet No. 09-02-04. *Reclaimed Water Systems. Information about installing, modifying or maintaining reclaimed water systems*.

Materials for gutters, rainwater pipes and joints

1.16 The materials used should be of adequate strength and durability, and

- a. all gutter joints should remain water tight under working conditions. Pipes inside a building should be capable of withstanding the air tightness test described in paragraph 1.38 of Requirement 6.1, and
- b. pipework in siphonic roof drainage systems should be able to resist to negative pressures in accordance with the design, and
- c. gutters and rainwater pipes should be firmly supported without restricting thermal movement, and
- d. different metals should be separated by non-metallic material to prevent electrolytic corrosion.

Alternative approach

1.17 The performance can also be met by following the relevant recommendations of BS EN 12056 *Gravity drainage systems inside buildings*. The relevant clauses are in Part 3 *Roof drainage layout and calculation*, Clauses 3 to 7, annex A and National Annexes, and in Part 5 *Installation, testing instructions for operation maintenance and use*, Clauses 3, 4, 6 and 11. These standards contain additional detailed information about design and construction.

Section 2: Surface water drainage

2.1 The following provisions apply if the drainage system is to carry only rainwater.

Outlets

2.2 Surface water drainage should discharge to a soakaway or other infiltration system where practicable.

2.3 Discharge to a watercourse may require a consent from the the Transport and Technical Services Department, who may limit the rate of discharge. Maximum flow rates can be limited by provision of attenuation tanks or detention ponds (see paragraph 2.34).

2.4 Where it is proposed to connect a drainage system to a public sewer consultation with the Transport and Technical Services Department is required under the Drainage (Jersey) Law 2005.

Combined systems

2.5 Some sewers carry both foul water and surface water (combined systems) in the same pipe. Where they do the Transport and Technical Services Department may allow surface water to discharge into the system if the sewer has enough capacity to take the added flow (see Requirement 6.1 paragraph 2.2). Some private sewers (drains serving more than one building that have not been adopted by the Transport and Technical Services Department) also carry both foul water and surface water. If a sewer operated as a combined system does not have enough capacity, the surface water should be run in a separate system with its own outfall.

2.6 In some circumstances, where a sewer is operated as a combined system and has sufficient capacity, separate drainage may still be required.

2.7 Where it is proposed to connect surface water drainage to a combined sewer the system should be designed so as to keep surface water and foul drainage separate up to a point near the site boundary, and the surface water drainage should have traps on all inlets.

Design rainfall intensities

2.8 Design rainfall intensities of 0.014 litres/second/m² may be assumed for normal situations.

2.9 Where low levels of surface flooding could cause flooding of buildings the rainfall intensities should be obtained from BS EN 752-4 (see paragraph 2.35).

Paragraph 2.8 - Correction.

Design rainfall intensities changed from 0.021 to 0.014.

Design

2.10 Where there is evidence of a liability to surcharging from sewers, or levels in the building or on the site make gravity connection impracticable, surface water lifting equipment will be needed (see Requirement 6.1 paragraphs 2.8 to 2.12).

Layout

2.11 Refer to paragraphs 2.13 to 2.21 of Requirement 6.1.

Depth of pipes

2.12 Refer to paragraphs 2.27 and 2.28 of Requirement 6.1.

Pipe gradients and sizes

2.13 Drains should have enough capacity to carry the flow. The capacity depends on the size and gradients of the pipes.

2.14 Drains should be at least 75mm diameter. Surface water sewers (serving more than one building) should have a minimum size of 100mm. Diagram 1 shows the capacities of drains of various sizes at different gradients. However the capacity can be increased by increasing the gradient, or by using larger pipes.

2.15 75mm and 100mm rainwater drains should be laid at not less than 1:100. 150mm drains and sewers should be laid at gradients not less than 1:150 and 225mm drains should be laid at gradients not less than 1:225. For minimum gradients for larger pipes see BS EN 752-4 (see paragraph 2.35).

Diagram 1 Discharge capacities of rainwater drains running full

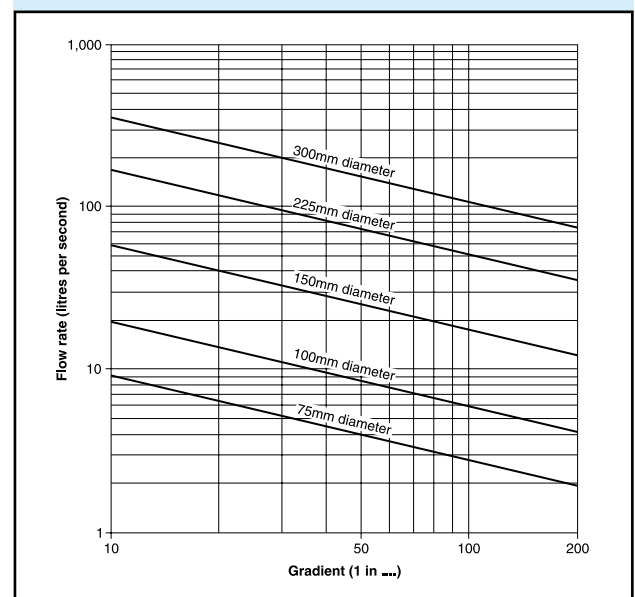

Materials for pipes and jointing

2.16 See paragraph 2.40 of Requirement 6.1.

Bedding and backfilling

2.17 See paragraphs 2.41 to 2.45 of Requirement 6.1.

Clearance of blockages

2.18 See paragraphs 2.46 to 2.54 of Requirement 6.1.

Workmanship

2.19 See paragraphs 2.55 to 2.58 of Requirement 6.1.

Testing and inspection

2.20 See paragraphs 2.59 to 2.62 of Requirement 6.1.

Contaminated runoff

2.21 On car parks, petrol filling stations or other areas where there is the potential for contaminated runoff from fuel leakage or spillage of oil, advice should be sought from the Department's Environmental Protection Officer and the Transport and Technical Services Department as to what precautions should be taken. This could include the provision of oil interceptors or other form of separator. It is an offence under Article 16 of the Drainage (Jersey) Law 2005 to cause or knowingly discharge oil or petrol into any drain or sewer connected to a public sewer.

Soakaways and other infiltration drainage systems

2.22 Infiltration devices include soakaways, swales, infiltration basins and filter drains.

2.23 Further information on the design of infiltration drainage systems can be found in CIRIA Report 156 – *Infiltration drainage – Manual of good practice*.

2.24 Infiltration drainage is not always possible. Infiltration devices should not be built:

- a. within 5m of a building;
- b. in ground where the water table reaches the bottom of the device at any time of the year;
- c. within a distance of any drainage fields, drainage mounds or other soakaways that would result in the overall soakage capacity of the ground being exceeded or the effectiveness of any drainage field being impaired (see guidance for Requirement 6.2);
- d. where the presence of any contamination in the runoff could result in pollution of a groundwater source or resource.

2.25 **Soakaways** for areas less than 100m² are generally formed from square or circular pits, filled with rubble or lined with dry-jointed masonry or perforated ring units. Soakaways serving larger areas are generally lined pits or trench type soakaways.

2.26 Soakaways should be designed to a return period of once in ten years. The design should be carried out with storms of differing durations to determine the duration which gives the largest storage volume. For small soakaways serving 25m² or less a design rainfall of 10mm in 5 minutes may be assumed to give the worst case. For soakaways serving larger areas reference should be made to the sources listed in paragraph 2.29. Where the ground is marginal overflow drains can be acceptable.

2.27 Percolation tests should be carried out to determine the capacity of the soil (see Requirement 6.2 paragraphs 1.23 to 1.27). Where the test is carried out in accordance with this Technical Guidance Document, the soil infiltration rate (f) is related to the value V_p derived from the test by the equation:

$$f = \frac{10^{-3}}{2V_p}$$

2.28 The storage volume should be calculated so that, over the duration the storm, it is sufficient to contain the difference between the inflow volume and the outflow volume. The inflow volume is calculated from the rainfall depth (see paragraph 2.25) and the area drained. The outflow volume (O) is calculated from the equation:

$$O = a_{s50} \times f \times D$$

Where a_{s50} is the area of the side of the storage volume when filled to 50% of its effective depth, and D is the duration of the storm in minutes.

2.29 Soakaways serving larger areas should be designed in accordance with BS EN 752-4 (see paragraph 2.35), or BRE Digest 365 *Soakaway design*.

Other types of infiltration system

2.30 **Swales** are grass-lined channels which transport rainwater from a site as well as controlling flow and quality of surface runoff. Some of the flow infiltrates into the ground. There may be an overflow at the end into another form of infiltration device or a watercourse. They are particularly suitable for treatment of runoff from small residential developments, parking areas and roads.

2.31 **Infiltration basins** are dry grass-lined basins designed to promote infiltration of surface water to the ground.

2.32 Filter drains or french drains consist of the trench, lined with a geotextile membrane and filled with gravel. Much of the flow infiltrates into the ground. A perforated pipe is often laid through the gravel to assist drainage.

2.33 Flow enters the top of the filter drain directly from runoff, or is discharged into it through drains.

Detention ponds

2.34 Detention ponds are used to attenuate the flow from a drainage system, to limit the peak rate of flow into a sewer system or watercourse. Further information on design may be found in the references given in paragraph 2.35 and in *Sustainable Urban Drainage Systems – A Design Manual for England and Wales* published by CIRIA.

Alternative approach

2.35 The requirement can also be met by following the relevant recommendations of BS EN 752-4 *Drain and sewer systems outside buildings*. The relevant clauses are in Part 4 *Hydraulic design and environmental considerations* Clauses 3 to 12 and National Annexes NA, NB and ND to NI. BS EN 752, together with BS EN 1295 and BS EN 1610, contains additional detailed information about design and construction.

The Requirement 6.4

This Technical Guidance Document, which takes effect on 01 July 2014, deals with the following requirements in the Building Bye-laws (Jersey) 2007, as amended.

<i>Requirement</i>	<i>Limits on application</i>
6.4 Sanitary facilities A building must have adequate sanitary facilities in rooms provided for that purpose.	

Guidance

Performance

In the Minister's view Requirement 6.4 will be met if:

- a. Sanitary conveniences of the appropriate type for the sex and age of the persons using the **building** are provided in sufficient numbers, taking into account the nature of the **building**; and
- b. hand washing facilities, with hot and cold water, are provided in, or adjacent to, rooms containing **sanitary conveniences** and are sited, designed and installed so as not to be prejudicial to health.
- c. in dwellings a bathroom containing a fixed bath or shower and wash hand basin having supplies of hot and cold water with a connection to a foul water drainage system.

General

1.1 Attention is also drawn to the requirements for accessible **sanitary conveniences** and hand washing facilities of Part 8 (Access to and use of buildings) of Schedule 2 to the Building Bye-laws 2007 and to Technical Guidance Document 8.

1.2 Requirement for ventilation is in Part 5 (Ventilation) of Schedule 2 to the Building Bye-laws 2007. Guidance on ventilation of **sanitary accommodation** is given in Technical Guidance Document Part 5.

1.3 The number, type and siting of **sanitary conveniences**, including separate provision for men and women and staff in Licensed Premises and Places of Refreshment are subject to the Environmental Health requirements. Attention is drawn to the Guidance Note issued by Environmental Health with regard to those requirements.

1.4 Further guidance on washbasins associated with **sanitary conveniences** may be found in the Food Standards Agency's Code of Practice *Food hygiene – a guide for businesses*.

1.5 Guidance on the selection, installation and maintenance of **sanitary appliances** including composting toilets may be found in BS 6465-3:2006 *Sanitary installations. Code of practice for the selection, installation and maintenance of sanitary and associated appliances*.

1.6 Where hot and cold taps are provided on a **sanitary appliance**, the hot tap should be on the left.

Scale of provision and layout in dwellings

1.7 Any dwelling (house or flat) should have at least one **sanitary convenience** and associated hand washing facility. This will include a **WC** provided in accordance with requirement 8.4 (Sanitary conveniences in dwellings) of Schedule 2 to the Building Bye-laws 2007 and with Technical Guidance Document 8.

Note: Paragraph 8.4 requires that a **sanitary convenience** should be located in the principal/entrance storey of a dwelling.

1.8 Where additional **sanitary conveniences** are provided, each should have an associated hand washing facility.

1.9 To allow for basic hygiene, hand washing facilities should be located in:

- a. the room containing the **sanitary convenience**; or
- b. an adjacent room or place that provides the sole means of access to the room containing the **sanitary convenience** (provided that it is not used for the **preparation of food**).

1.10 A place containing a **sanitary convenience** and/or associated hand washing facilities should be separated by a door from any place used for the **preparation of food** (including a **kitchen**) (see Diagrams 1 and 2).

Note: In dwellings, a room containing both a **sanitary convenience** and a basin for hand washing does not need a separation lobby between this room and a **kitchen** or food preparation area (Diagram 1). The layout for a room containing a **sanitary convenience** only should be such that the room or space containing its associated hand washing facilities is accessed before entry to a food preparation area, and is separated from that area by a door (Diagram 2).

1.11 Guidance on the provision of activity space around **sanitary appliances** is given in BS 6465-2:1996 *Sanitary installations. Code of practice for space requirements for sanitary appliances*.

Diagram 1 **Separation between hand washbasin/WC and food preparation area – single room**

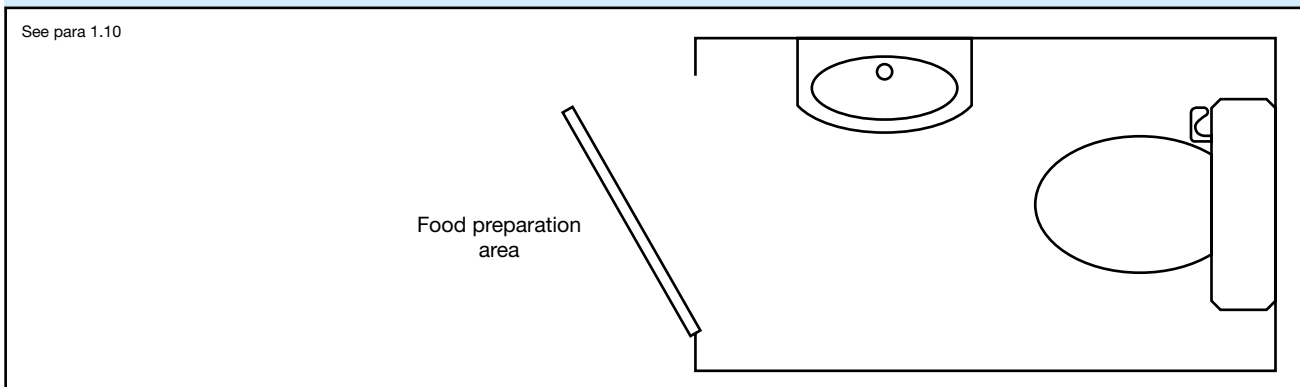
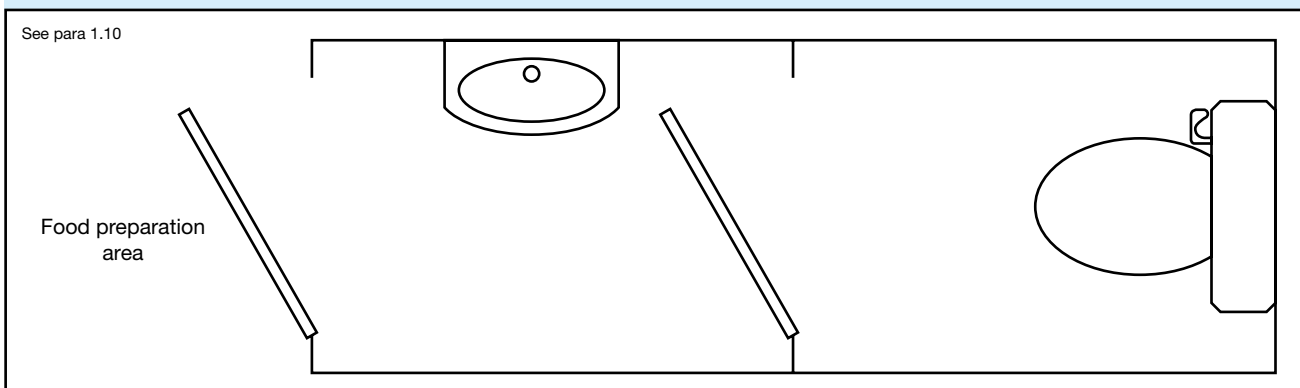

Diagram 2 **Separation between hand washbasin/WC and food preparation area – two rooms**



Scale of provision and layout in buildings other than dwellings

1.12 Part 8 of Schedule 2 to the Building Bye-laws 2007 sets out requirements relating to access to and use of buildings. Technical Guidance Document 8 provides guidance on the provision of suitable **sanitary accommodation**. Such accommodation may form part of the total number of **sanitary conveniences** provided within a **building**.

1.13 Guidance on the provision of sanitary conveniences can be found in BS 6465-1:2006 + A1:2009 *Sanitary installations. Code of practice for the design of sanitary facilities and scales of provision of sanitary and associated appliances*. Requirement 6.4 will be met by following the relevant recommendations of that Code of Practice.

1.14 A **sanitary convenience** may be provided in:

- a self-contained room which also contains hand washing facilities;
- in a cubicle with shared hand washing facilities located in a room containing a number of cubicles; or
- in a self-contained room with hand washing facilities provided in an adjacent room.

1.15 Urinals, WC cubicles and hand washing facilities may be in the same room.

1.16 A place containing a **sanitary convenience** and/or associated hand washing facilities should be separated by a door from any place used for the **preparation of food** (including a **kitchen**).

1.17 Guidance on the provision of activity space around **sanitary appliances** is given in BS 6465-2:1996 *Sanitary installations. Code of practice for space requirements for sanitary appliances*.

Chemical and composting toilets

1.18 Chemical toilets or composting toilets may be used where:

- a. suitable arrangements can be made for the disposal of the waste either on or off the site; and
- b. the waste can be removed from the premises without carrying it through any food preparation areas (including a **kitchen**); and
- c. no part of the installation would be installed in any places where it might be rendered ineffective by the entry of flood water.

1.19 There are currently no British or European standards for composting toilets. Appropriate guidance can be found in ANSI/NSF 41:2005 as amended by Addendum 1:2007 *Non-liquid saturated treatment system*.

1.20 Rooms containing composting toilets should be provided with ventilation that meets the minimum extract rates given for sanitary accommodation in the Technical Guidance Document 5.

Discharges to drains

Note: See Technical Guidance Document for requirement 6.1 *Sanitary pipework and drainage* for guidance on provision for traps, branch discharge pipes, discharge stacks and foul drains.

1.21 Any **WC** fitted with flushing apparatus should discharge to an adequate system of drainage.

1.22 A **urinal** fitted with flushing apparatus should discharge through a grating, a trap or mechanical seal and a branch pipe to a discharge stack or a drain.

1.23 A **WC** fitted with a macerator and pump may be connected to a small bore drainage system discharging to a discharge stack if:

- a. there is also access to a **WC** discharging directly to a gravity system; and
- b. the macerator and pump meets the requirements of BS EN 12050-1:2001 *Wastewater lifting plants for buildings and sites. Principles of construction and testing. Lifting plants for wastewater containing faecal matter* or BS EN 12050-3:2001 *Wastewater lifting plants for buildings and sites. Principles of construction and testing. Lifting plants for wastewater containing faecal matter for limited applications*.

Note: Where **greywater** recycling is used, lower overall flows are to be expected and this should be taken into account in drain design. This is particularly relevant at the head of the drain where only one **building** is connected to the drain.

The Requirement 6.5

This Technical Guidance Document, which takes effect on 01 July 2014, deals with the following requirements in the Building Bye-laws (Jersey) 2007, as amended.

<i>Requirement</i>	<i>Limits on application</i>
<p>6.5 Hot water storage and supply</p> <p>(1) A hot water storage system with a hot water storage vessel must be designed and installed so as to operate safely, and in particular must incorporate precautions to –</p> <p>(a) prevent the temperature of stored water exceeding 100°C at any time; and</p> <p>(b) ensure that any discharge from safety devices forming part of the system is safely conveyed to a point where it is visible but will cause no danger to persons in or about the building.</p> <p>(2) A system supplying hot water to any fixed bath must be designed and installed so as to operate safely, and in particular must incorporate precautions to ensure that the temperature of water delivered to the bath at any time cannot exceed 48°C.</p>	<p>Sub-paragraph (1) does not apply to –</p> <p>(a) a hot water storage system with a hot water storage vessel having a capacity of 15 litres or less;</p> <p>(b) a [hot water storage] system that provides only space heating;</p> <p>(c) a system that heats or stores water only for an industrial process.</p> <p>Sub-paragraph (2) applies only when a dwelling is –</p> <p>(a) erected; or</p> <p>(b) formed as a result of a material change of use of a building.</p>

Guidance

Performance

In the Minister's view Requirement 6.5 (1) will be met for a **hot water storage system** that has a vented storage vessel if:

- the storage vessel has a suitable vent pipe connecting the top of the vessel to a point open to the atmosphere above the level of the water in the cold water storage cistern and over it; and,
- in addition to any thermostat, either the heat source, or the storage vessel is fitted with a device that will prevent the temperature of the stored water at any time exceeding 100°C; and
- the hot water system has pipework that incorporates a provision for the discharge of hot water from the safety devices to an appropriate place open to the atmosphere where it will cause no danger to persons in or about the **building**.

In the Minister's view Requirement 6.5 (1) will be met for a hot water system that has an unvented storage vessel if:

- the storage vessel has at least two independent safety devices such as those that release pressure and so prevent the temperature of the stored water at any time exceeding 100°C in addition to any thermostat; and
- the hot water system has pipework that incorporates a provision for the discharge of hot water from safety devices to be visible at some point and safely conveys it to an appropriate place open to the atmosphere where it will cause no danger to persons in or about the **building**.

In the Minister's view Requirement 6.5 (2) will be met if:

- the hot water outlet temperature is appropriate for the appliance being served, and any device to limit the maximum temperature that can be supplied cannot be easily altered by building users.

General

1.1 Electrical work associated with hot water systems should be carried out in accordance with BS7671:2008 *Requirements for electrical installations (IEE Wiring Regulations 17th Edition)*.

1.2 For electrical installation work, attention is drawn to Part 12 of the Second Schedule to Building Bye-laws (Electrical safety) and to Technical guidance Document 12.

Design and installation of directly or indirectly heated hot water storage systems

General

1.3 Hot water storage systems should be

designed and installed in accordance with BS 6700:2006 + A1:2009 *Specification for design, installation, testing and maintenance of services supplying water for domestic use within buildings and their curtilages* or BS EN 12897:2006 *Water supply. Specification for indirectly heated unvented (closed) storage water heaters*.

1.4 Hot water storage vessels should conform to BS 853-1:1996 *Specification for vessels for use in heating systems. Calorifiers and storage vessels for central heating and hot water supply*, BS 1566-1:2002 *Copper indirect cylinders for domestic purposes. Open vented copper cylinders. Requirements and test methods*, or BS 3198:1981 *Specification for copper hot water storage combination units for domestic purposes* or other relevant national standards as appropriate.

Vented hot water storage systems

1.5 Vented **hot water storage systems** should incorporate a vent pipe of an adequate size, but not less than 19mm internal diameter, connecting the top of the hot water storage vessel to a point open to the atmosphere above and over the level of the water in the cold water storage cistern.

1.6 In addition to the vent pipe referred to in 1.5 above and any thermostat provided to control the temperature of the stored water to a desired temperature, vented **hot water storage systems** should incorporate either:

- for all direct heat sources, a non-self-resetting energy cut-out to disconnect the supply of heat to the storage vessel in the event of the storage system overheating; and, for all indirect heat sources, an overheat cut-out to disconnect the supply of heat to the storage vessel in the event of the stored water overheating so that the temperature of the stored water does not exceed 100°C; or
- an appropriate safety device, for example, a **temperature relief valve** or a **combined temperature and pressure relief valve** to safely discharge the water in the event of significant over heating.

1.7 Vent pipes should discharge over a cold water storage cistern conforming to BS 417-2:1987 *Specification for galvanized low carbon steel cisterns, cistern lids, tanks and cylinders. Metric units*; or BS 4213:2004 *Cisterns for domestic use. Cold water storage and combined feed and expansion (thermoplastic) cisterns up to 500 litres. Specification*; as appropriate.

1.8 The cold water storage cistern into which the vent pipe discharges should be supported on a flat, level, rigid platform which is capable of safely withstanding the weight of the cistern when filled with water to the rim and fully supporting the bottom of the cistern over the whole of its area. The platform should extend a minimum of 150mm in all directions beyond the edge of the maximum dimensions of the cistern.

6.5 HOT WATER SYSTEMS

Note: Where an existing metal cistern is replaced, or a plastic cistern is replaced by one with larger dimensions, the existing support should be upgraded, as necessary, with one in accordance with paragraph 1.8.

1.9 The cistern should be accessible for maintenance, cleaning and replacement.

Unvented hot water storage systems – all systems

1.10 To minimize the danger from excessive pressure, unvented hot water storage systems should incorporate a minimum of two independent safety devices. These shall be in addition to any thermostat provided to control the desired temperature of the stored water. The selection of safety devices should take account of the physical location of the devices, and the design, configuration, location of components and performance characteristics of the system to which they are attached.

1.11 An acceptable approach might consist of:

- a. a non self-resetting energy cut-out to disconnect the supply of heat to the storage vessel in the event of the storage system over-heating; and
- b. a temperature relief valve or a combined temperature and pressure relief valve to safely discharge the water in the event of serious over-heating.

Alternative approaches to this are acceptable provided that they provide an equivalent degree of safety.

Note: See 1.27 for suitability of devices for primary thermal stores

Unvented hot water storage systems – systems up to 500 litres capacity and 45kW power input

1.12 Paragraphs 1.13 to 1.16 are in addition to the provisions of 1.10 above.

1.13 If an indirect supply of heat to an unvented **hot water storage system** incorporates a boiler, the energy cut-out may be on the boiler.

1.14 Any unvented **hot water storage system** up to 500 litres and less than 45kW should be in the form of a proprietary **hot water storage system unit** or package. The package and components should be appropriate to the circumstances in which they are used and should satisfy an appropriate standard that will ensure requirement of 6.5 will be met (e.g. BS EN 12897:2006 *Water Supply. Specification for indirectly heated unvented (closed) hot water storage systems* or BS 6700:2006 + A1:2009 *Design, installation, testing and maintenance of services supplying water for domestic use within buildings and their curtilages*).

1.15 Any unvented **hot water storage system unit** or package should be indelibly marked with the following information:

- a. the manufacturer's name and contact details;
- b. a model reference;
- c. the rated storage capacity of the storage water heater;
- d. the operating pressure of the system and the operating pressure of the expansion valve;
- e. relevant operating data on each of the safety devices fitted; and
- f. the maximum primary circuit pressure and flow temperature of indirect **hot water storage system units** or **packages**.

1.16 In addition, the following warning should be indelibly marked on the **hot water storage system unit** or package so that it is visible after installation:

WARNING TO USER

- a. Do not remove or adjust any component part of this unvented water heater; contact the installer.
- b. If this unvented water heater develops a fault, such as a flow of hot water from the discharge pipe, switch the heater off and contact the installer.

WARNING TO INSTALLER

- a. This installation is subject to the Building Bye-Laws.
- b. Use only appropriate components for installation or maintenance.

Installed by:

Name

Address

Tel. No.

Completion date

Unvented hot water storage systems – systems over 500 litres capacity or over 45kW power input

1.17 Paragraph 1.18 and 1.19 are in addition to the provisions of 1.10 above.

1.18 Systems over 500 litres capacity will generally be bespoke designs for specific projects and as such are inappropriate for approval by a third party accredited product conformity certification scheme. Where this is the case, the unvented **hot water storage system** should be designed to the safety requirements in 1.10 by an appropriately qualified engineer.

1.19 Any unvented **hot water storage system** having a power input of more than 45kW, but a capacity of 500 litres or less should be in the form of a proprietary **hot water storage system unit** or package. The package and components should be appropriate to the circumstances in which they are used and should satisfy an appropriate standard that will ensure requirement 6.5 will be met (e.g. BS EN 12897:2006 *Water Supply. Specification for indirectly heated unvented (closed) hot water storage systems* or BS 6700:2006 + A1:2009 *Design, installation, testing and maintenance of services supplying water for domestic use within buildings and their curtilages*).

Safety devices

Non-self-resetting energy cut-outs

1.20 Non-self-resetting energy cut-outs may only be used where they would have the effect of instantly disconnecting the supply of energy to the storage vessel.

1.21 Non-self-resetting energy cut-outs should conform to:

- a. BS EN 60335-2-73:2003 *Specification for safety of household and similar electrical appliances. Particular requirements. Fixed immersion heaters* and BS EN 60730-2-9:2002 *Automatic electrical controls for household and similar use. Particular requirements for temperature sensing control*; or
- b. BS EN 257:1992 *Mechanical thermostats for gas-burning appliances*.

1.22 Where a non self-resetting energy cut-out operates indirectly on another device (see paragraph 1.11) to interrupt the supply of heat (e.g. it is wired up to a motorised valve or some other suitable device to shut off the flow to the primary heater), the energy cut-out should comply with the relevant European Standard (see paragraph 1.21) or the supplier or installer should be able to demonstrate that the device has equivalent performance to that set out in relevant standards.

1.23 Where an electrical device is connected to the energy cut-out, such as a relay or motorised valve, the device should operate to interrupt the supply of energy if the electrical power supply is disconnected.

1.24 Where there is more than one energy cut-out (see paragraph 1.27), each non-self-resetting energy cut-out should be independent (e.g. each should have a separate motorised valve and a separate temperature sensor).

1.25 Where an energy cut-out is fitted as set out in paragraphs 1.6 a) or 1.11, each heat source should have a separate non self-resetting energy cut-out.

Temperature and pressure relief devices

1.26 Where relevant, appropriate pressure, temperature or temperature and pressure-activated safety devices should be fitted in addition to a safety device such as an energy cut-out.

1.27 Temperature relief valves and **combined temperature and pressure relief valves** should not be used in systems which have no provision to automatically replenish the stored water (e.g. unvented primary thermal storage vessels). In such cases there should be a second non-self-resetting energy cut-out independent of the one provided in accordance with paragraph 1.11(a).

1.28 Temperature relief valves should conform to relevant national standards such as BS 6283-2:1991 *Safety and control devices for use in hot water systems. Specifications for temperature relief valves for pressures from 1 bar to 10 bar. Combined temperature and pressure relief valves* should conform to BS EN 1490:2000 *Building valves. Combined temperature and pressure relief valves. Tests and Requirements*.

1.29 **Temperature relief valves** (see paragraph 1.11) should be sized to give a discharge rating at least equal to the total power input to the hot water storage system, when measured in accordance with Appendix F of BS 6283-2:1991 or BS EN 1490:2000.

1.30 **Temperature relief valve(s) or combined temperature and pressure relief valve(s)** (see paragraph 1.11) should be located directly on the storage vessel, such that the stored water does not exceed 100°C.

1.31 In **hot water storage system units** and packages, the **temperature relief valve(s)** (see paragraph 1.11) should be:

- a. factory fitted and should not be disconnected other than for replacement; and
- b. not relocated in any other device or fitting installed.

1.32 The safety and performance of an unvented system is dependent on the choice of system and safety devices appropriate for the location and correct installation of the system. Building owners and occupiers should therefore take care to choose installers who have the necessary skills to carry out this work. These skills can be demonstrated for example, by registration with a competent person scheme for this type of work or by the holding of a current registered operative skills certification card for unvented hot water systems.

1.33 The installation of an unvented system is notifiable building work which must be notified to the **Department** before work commences. The **Department** may then check to make sure the work is safe and meets current energy efficiency requirements.

1.34 If the installer is registered with a competent person scheme for the installation of unvented hot water systems it will not be necessary for the work to be notified in advance to the **Department**. Installers registered with such schemes will self-certify that the work complies with all relevant requirements in the Building Bye-laws and the building owner/occupier will be given a building bye-laws certificate of compliance which is usually issued by the competent person scheme operator.

Electric water heating

1.35 Electric fixed immersion heaters should comply with the provisions of BS EN 60335-2-73:2003 *Household and similar electrical appliances. Safety. Particular requirements for fixed immersion heaters*.

1.36 Electric instantaneous water heaters should comply with the provisions of BS EN 60335-2-35:2002 *Specification for safety of household and similar electrical appliances*.

1.37 Electric storage water heaters should comply with the provisions of BS EN 60335-2-21:2003 *Household and similar electrical appliances. Safety. Particular requirements for storage water heaters*.

Solar water heating

1.38 Factory-made solar water heating systems should comply with the provisions of BS EN 12976-1:2006 *Thermal solar systems and components. Factory made systems. General requirements*.

1.39 Other solar water heating systems should comply with the provisions of prEN/TS 12977-1:2008 *Thermal solar systems and components. Custom built systems. General requirements for solar water heaters and combi systems*, or BS 5918:1989 *British Standard Code of Practice for Solar heating systems for domestic hot water* as appropriate. Further guidance is available in *CIBSE Guide G, Public Health Engineering and CIBSE technical guide Solar Heating Design and Installation*.

1.40 Where solar water heating systems are used, an additional heat source should be available.

Note: The additional heat source should be used, when necessary, to maintain the water temperature to restrict microbial growth.

1.41 As some solar hot water systems operate at elevated temperatures and pressures, and so all components should be rated to the appropriate temperatures and pressures.

Discharge pipes from safety devices

Discharge pipe D1

1.42 Safety devices such as **temperature relief valves** or **combined temperature and pressure relief valves** (see paragraphs 1.6 or 1.11) should discharge either directly or by way of a manifold via a short length of metal pipe (D1) to a **tundish**.

1.43 The diameter of discharge pipe (D1) should be not less than the nominal outlet size of the safety device, e.g. **temperature relief valve**.

1.44 Where a manifold is used it should be sized to accept and discharge the total discharge from the discharge pipes connected to it.

1.45 Where valves other than a **temperature and pressure relief valve** from a single unvented hot water system discharge by way of the same manifold that is used by the safety devices, the manifold should be factory fitted as part of the **hot water storage system unit** or package.

Tundish

1.46 The **tundish** should be vertical, located in the same space as the unvented **hot water storage system** and be fitted as close as possible to, and lower than, the safety device, with no more than 600mm of pipe between the valve outlet and the **tundish** (see Diagram 1).

Note: To comply with the Water Supply (Water Fittings) Regulations, the **tundish** should incorporate a suitable air gap.

1.47 Any discharge should be visible at both the **tundish** and the final point of discharge but where this is not possible or is practically difficult there should be clear visibility at one or other of these locations. In addition, where discharges from safety devices may not be apparent, e.g. in dwellings occupied by people with impaired vision or mobility, consideration should be given to the installation of a suitable safety device to warn when discharge takes place, e.g. electronically operated.

Discharge pipe D2

1.48 The discharge pipe (D2) from the **tundish** should:

- have a vertical section of pipe at least 300mm long below the **tundish** before any elbows or bends in the pipework (see Diagram 1); and
- be installed with a continuous fall of at least 1 in 200 thereafter.

1.49 The discharge pipe (D2) should be made of:

- metal; or
- other material that has been demonstrated to be capable of safely withstanding temperatures of the water discharged and is clearly and permanently marked to identify the product and performance standard (e.g. as specified in the relevant part of BS 7291-

1:2006 *Thermostatic pipes and fittings for hot and cold water for domestic purposes and heating installations in buildings. General requirements*).

1.50 The discharge pipe D2 should be at least one pipe size larger than the nominal outlet size of the safety device unless its total equivalent hydraulic resistance exceeds that of a straight pipe 9m long, i.e. for discharge pipes between 9m and 18m the equivalent resistance length should be at least two sizes larger than the nominal outlet size of the safety device; between 18 and 27m at least 3 sizes larger, and so on; bends must be taken into account in calculating the flow resistance. See Diagram 1, Table 1 and the worked example.

Note: An alternative approach for sizing discharge pipes would be to follow Annex D, section D.2 of BS 6700:2006 + A1:2009 *Specification for design, installation, testing and maintenance of services supplying water for domestic use within buildings and their curtilages*.

Diagram 1 Typical discharge pipe arrangement

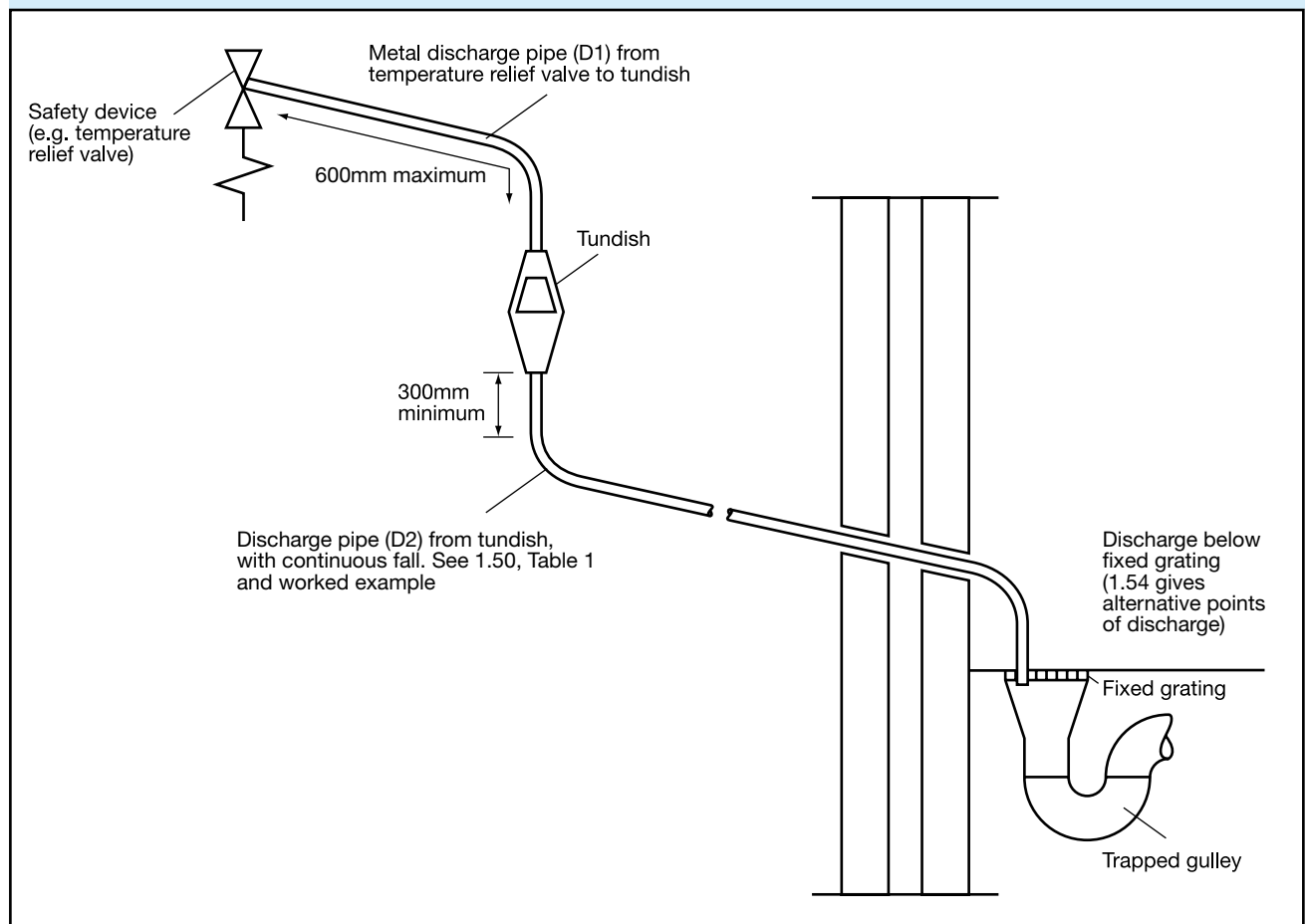

Table 1 Sizing of copper discharge pipe 'D2' for common temperature relief valve outlet sizes

Valve outlet size	Minimum size of discharge pipe D1*	Minimum size of discharge pipe D2* from tundish	Maximum resistance allowed, expressed as a length of straight pipe (i.e. no elbows or bends)	Resistance created by each elbow or bend
G½	15mm	22mm	Up to 9m	0.8m
		28mm	Up to 18m	1.0m
		35mm	Up to 27m	1.4m
G¾	22mm	28mm	Up to 9m	1.0m
		35mm	Up to 18m	1.4m
		42mm	Up to 27m	1.7m
G1	28mm	35mm	Up to 9m	1.4m
		42mm	Up to 18m	1.7m
		54mm	Up to 27m	2.3m

*see 1.43 and 1.48 and Diagram 1

Note: The above table is based on copper tube. Plastic pipes may be of different bore and resistance.

Sizes and maximum lengths of plastic should be calculated using data prepared for the type of pipe being used.

Worked example:

The example below is for a G½ **temperature relief valve** with a discharge pipe (D2) having 4 No. 22mm elbows and length of 7m from the **tundish** to the point of discharge.

From Table 1:

Maximum resistance allowed for a straight length of 22mm copper discharge pipe (D2) from a G½ **temperature relief valve** is: 9.0m

Subtract the resistance for 4 No. 22mm elbows at 0.8m each = 3.2m

Therefore the maximum permitted length equates to 5.8m which, is less than the actual length of 7m therefore calculate the next largest size.

Maximum resistance allowed for a straight length of 28mm copper discharge pipe (D2) from a G½ **temperature relief valve** is: 18m

Subtract the resistance for 4 No. 28mm elbows at 1.0m each = 4m

Therefore the maximum permitted length equates to: 14m

As the actual length is 7m, a 28mm (D2) copper pipe will be satisfactory.

1.51 Where a single common discharge pipe serves more than one system, it should be at least one pipe size larger than the largest individual discharge pipe (D2) to be connected.

1.52 The discharge pipe should not be connected to a soil discharge stack (see note 1) unless it can be demonstrated that the soil discharge stack is capable of safely withstanding temperatures of the water discharged, in which case, it should:

- contain a mechanical seal, not incorporating a water trap, which allows water into the branch pipe without allowing foul air from the drain to be ventilated through the **tundish**;
- be a separate branch pipe with no **sanitary appliances** connected to it;
- if plastic pipes are used as branch pipes carrying discharge from a safety device, they should be either polybutalene (PB) or cross-linked polyethylene (PE-X) complying with national standards such as Class S of BS 7291-2:2006 or Class S of BS 7291-3:2006 respectively; and
- be continuously marked with a warning that no **sanitary appliances** should be connected to the pipe.

Notes:

- Connection of discharge pipework to a soil discharge stack may not be considered acceptable for the purposes of the water supply bye-laws. Jersey Water should be consulted before adopting this method of discharge.
- Plastic pipes should be joined and assembled with fittings appropriate to the circumstances in which they are used as set out in BS EN ISO 1043-1:2002 *Plastics. Symbols and abbreviated terms. Basic polymers and their special characteristics*.
- Where pipes cannot be connected to the stack it may be possible to route a dedicated pipe alongside or in close proximity to the discharge stack.

Termination of discharge pipe

1.53 The discharge pipe (D2) from the **tundish** should terminate in a safe place where there is no risk to persons in the vicinity of the discharge. Where more than one discharge pipe terminates in the same location the appliance connected to each discharge pipe should be easily identified.

1.54 Examples of acceptable discharge arrangements are:

- a. to a trapped gully with the end of the pipe below a fixed grating and above the water seal;
- b. downward discharges at low level; i.e. up to 100mm above external surfaces such as car parks, hard standings, grassed areas etc. are acceptable providing that a wire cage or similar guard is positioned to prevent contact, whilst maintaining visibility; and,
- c. discharges at high level: e.g. into a metal hopper and metal downpipe with the end of the discharge pipe clearly visible or onto a roof capable of withstanding high temperature discharges of water and 3 m from any plastic guttering system that would collect such discharges.

1.55 The discharge would consist of high temperature water and steam. Asphalt, roofing felt and non-metallic rainwater goods may be damaged by such discharges.

Prevention of excessive temperatures

1.56 Where the operating temperature of **domestic hot water** in the storage vessel in a dwelling is capable of exceeding 80°C under normal operating conditions (a situation that may occur in vessels used as heat stores and those connected to solar heat collectors or solid fuel boilers that do not have intervening controls between the boiler and the vessel containing the hot water) the outlet from the storage vessel should be fitted with a device, such as an in-line hot water supply tempering valve in accordance with BS EN 15092:2008 *Building Valves. In-line hot water tempering valves*, to ensure that the temperature supplied to the **domestic hot water** distribution system does not exceed 60°C.

Prevention of scalding

1.57 The hot water supply temperature to a bath should be limited to a maximum of 48°C by use of an in-line blending valve or other appropriate temperature control device, with a maximum temperature stop and a suitable arrangement of pipework.

1.58 The acceptability of in-line blending valves can be demonstrated by compliance with the relevant European Standard such as BS EN 1111:1999 *Sanitary tapware. Thermostatic mixing valves (PN 10). General technical specification* or BS EN 1287:1999 *Sanitary tapware. Low pressure thermostatic mixing valves. General technical specifications* to demonstrate that the maximum temperature of 48°C cannot be exceeded in operation and that the product will fail-safe (i.e. not discharge water above the maximum temperature). Such valves should not be easily altered by **building** users.

Note:

Further guidance on the use of in-line blending valves can be found in BRE Information paper IP14/03 *Preventing hot water scalding in bathrooms: using TMVs*

Installation

1.59 Good workmanship is essential. Workmanship should be in accordance with appropriate standards such as BS 8000–15:1990 *Workmanship on Building Sites Code of practice for hot and cold water services (domestic scale)*.

Commissioning of fixed building services

1.60 Water heaters require the input of energy to raise the temperature of water. It is therefore necessary to ensure their efficiency by proper installation and commissioning.

1.61 Fixed **building** services, including controls, should be commissioned by testing and adjusting as necessary to ensure that they use no more fuel and power than is reasonable in the circumstances.

1.62 Commissioning means the advancement of these systems from the state of static completion to working order to achieving compliance with Part 11. For each system it includes setting-to-work, regulation (that is testing and adjusting repetitively) to achieve the specified performance, the calibration, setting up and testing of the associated automatic control systems, and recording of systems and the performance test results that have been accepted as satisfactory.

1.63 Not all fixed **building** services will need to be commissioned. For example, with some systems it is not possible as the only controls are 'on' and 'off' settings. In other cases commissioning would be possible but in the specific circumstances would have no effect on energy use.

1.64 Where commissioning is carried out it must be done in accordance with a procedure approved by the Minister. For new and existing dwellings the approved procedure for hot water systems is set out in the *Domestic Heating Compliance Guide*; for **buildings** other than dwellings in *CIBSE Commissioning Code M*.

1.65 Commissioning must be carried out in such a way as not to prejudice compliance with any applicable health and safety requirements.

1.66 Commissioning is often carried out by the person who installs the system. Sometimes it may be carried out by a subcontractor or by a specialist firm. It is important that whoever carries it out follows the relevant approved procedure in doing so.

The Requirement 6.6

This Technical Guidance Document, which takes effect on 01 July 2014, deals with the following requirements in the Building Bye-laws (Jersey) 2007, as amended.

<i>Requirement</i>	<i>Limits on application</i>
6.6 Water efficiency (1) A system supplying water to a dwelling must be designed and installed with reasonable regard to the efficient use of potable water.	Sub-paragraph (1) applies only when a dwelling is – (a) erected; or (b) formed as a result of a material change of use of a building.

Guidance

Performance

In the Minister's view requirement 6.6 will be met for newly created dwellings if:

- A calculation is provided showing the water used by **sanitary appliances** in the dwelling is estimated to be less than 120 litres/head/day (l/h/d); or
- rainwater harvesting or greywater systems are provided for flushing toilets and watering gardens; or
- water fittings achieving the efficiency standards set out in Table 1, are installed.

Where it can be demonstrated that a dwelling meets the minimum water efficiency standard in the UK Code for Sustainable Homes, the dwelling may be presumed to meet requirement 6.6.

General

1.1 The estimated water consumption of a new dwelling should be calculated in accordance with the UK Government's national calculation methodology for assessing water efficiency in new dwellings.

1.2 There are a number of rain water harvesting systems available with a range of features. BS 8515 gives guidance on the design, installation and maintenance of rain water harvesting systems for the supply of non-potable water and covers three basic types of system:

- Water collected in storage tanks(s) and pumped directly to points of use;
- Water collected in storage tanks(s) and fed by gravity to points of use; and
- Water collected in storage tanks(s), pumped to elevated cisterns and fed by gravity to the points of use.

Design and Installation

1.3 A rainwater harvesting system used for flushing toilets should be provided with a back-up supply from the public mains water supply or private well or bore-hole.

1.4 A rainwater harvesting system should be designed to achieve optimum storage taking into account the intensity of rainfall, the size and type of the collection surface and the number and type of intended applications.

Table 1 Water Fittings

WC (litres dual flush)	6/4
WC (litres single flush)	4.5
Basin Taps (litres per minute)	6
Shower (litres per minute)	10
Bath (litres)	185
Sink taps (litres per minute)	8

Notes:

- Jersey Water administer the Water (General Provisions) (Jersey) Bye-laws 1988. A person proposing to install a rainwater harvesting system is advised to consult Jersey Water to ensure the proposals conform with those bye-laws.
- Water fittings of the type listed in Table 1 may affect the pipe lengths required to satisfy the water bye-law requirements for hot water to achieve 50°C at point of use within 30 seconds.

Standards and references

Standards

ANSI-NSF 41:2005 + A1:2007. *Non-liquid saturated treatment system*. NSF, 2007.

BS EN 257:1992 *Mechanical thermostats for gas-burning appliances*. BSI, 1992.

BS 417-2:1987 *Specification for galvanized low carbon steel cisterns, cistern lids, tanks and cylinders. Metric units*. BSI, 1987.

BS 853-1:1996 *Specification for vessels for use in heating systems. Calorifiers and storage vessels for central heating and hot water supply*. BSI, 1996.

BS EN ISO 1043-1:2002 *Plastics. Symbols and abbreviated terms. Basic polymers and their special characteristics*.

BS EN 1111:1999 *Sanitary tapware. Thermostatic mixing valves (PN 10). General technical specification*. BSI, 1999.

BS EN 1287:1999 *Sanitary tapware. Low pressure thermostatic mixing valves. General technical specifications*. BSI, 1999.

BS EN 1490:2000 *Building valves. Combined temperature and pressure relief valves. Tests and requirements*. BSI, 2000.

BS 1566-1:2002 *Copper indirect cylinders for domestic purposes. Open vented copper cylinders. Requirements and test methods*. BSI, 2002.

BS 3198:1981 *Specification for copper hot water storage combination units for domestic purposes*. BSI, 1981.

BS 4213:2004 *Cisterns for domestic use. Cold water storage and combined feed and expansion (thermoplastic) cisterns up to 500 l. Specification*. BSI, 2004.

BS 5918:1989 *Code of Practice for Solar heating systems for domestic hot water*. BSI 1989.

BS 6283-2:1991 *Safety and control devices for use in hot water systems. Specifications for temperature relief valves for pressures from 1 bar to 10 bar*. BSI, 1991.

BS 6283-3:1991 *Safety and control devices for use in hot water systems. Specification for combined temperature and pressure relief valves for pressures from 1 bar to 10 bar*. BSI, 1991.

BS 6465-1:2006 + A1:2009 *Sanitary installations. Code of practice for the design of sanitary facilities and scales of provision of sanitary and associated appliances*. BSI, 2006.

BS 6465-2:1996 *Sanitary installations. Code of practice for space requirements for sanitary appliances*. BSI, 1996.

BS 6465-3:2006 *Sanitary installations. Code of practice for the selection, installation and maintenance of sanitary and associated*

appliances. BSI, 2006.

BS 6700:2006 + A1:2009 *Design, installation, testing and maintenance of services supplying water for domestic use within buildings and their curtilages. Specification*. BSI, 2006.

BS 7291-1:2006 *Thermoplastics pipes and associated fittings for hot and cold water for domestic purposes and heating installations in buildings. General requirements*.

BS 7291-2:2006 *Thermoplastics pipes and associated fittings for hot and cold water for domestic purposes and heating installations in buildings. Specification for polybutylene (PB) pipes and associated fittings*.

BS 7291-3:2006 *Thermoplastics pipes and associated fittings for hot and cold water for domestic purposes and heating installations in buildings. Specification for cross-linked polyethylene (PE-X) pipes and associated fittings*.

BS 7671:2008 *Requirements for electrical installations (IET Wiring Regulations 17th Edition)*.

BS 8000-15:1990 *Workmanship on Building Sites Code of practice for hot and cold water services (domestic scale)*. BSI, 1990.

BS 8515:2009 *Rainwater harvesting systems, Code of Practice*.

BS EN 12050-1:2001 *Wastewater lifting plants for buildings and sites. Principles of construction and testing. Lifting plants for wastewater containing faecal matter*.

BS EN 12050-2:2001 *Wastewater lifting plants for buildings and sites. Principles of construction and testing. Lifting plants for faecal-free wastewater*. BSI, 2001.

BS EN 12050-3:2001 *Wastewater lifting plants for buildings and sites. Principles of construction and testing. Lifting plants for wastewater containing faecal matter for limited applications*.

BS EN 12897:2006 *Water supply. Specification for indirectly heated unvented (closed) storage water heaters*. BSI, 2006.

BS EN 12976-1:2006 *Thermal solar systems and components. Factory made systems. General requirements*. BSI, 2006.

prCEN/TS 12977-1:2008 *Thermal solar systems and components. Custom built systems. General requirements*. BSI, 2001.

BS EN 15092:2008 *Building valves. Inline hot water supply tempering valves. Tests and requirements*. BSI, 2008.

BS EN 60335-2-21:2003 *Household and similar electrical appliances. Safety. Particular requirements for storage water heaters*. BSI, 2003.

BS EN 60335-2-35:2002 *Specification for safety of household and similar electrical appliances*. BSI, 2002.

BS EN 60335-2-73:2003 *Specification for safety of household and similar electrical appliances. Particular requirements for fixed immersion heaters*. BSI, 2003.

BS EN 60730-2-9:2002 *Automatic electrical controls for household and similar use. Particular requirements for temperature sensing controls*. BSI, 2002.

Other documents

Water Regulations Advisory Scheme. *Water Regulations Guide*. WRAS, 2000.

WRAS IGN 9-02-04: Issue 1: 1994. *Reclaimed water systems*. WRAS, 1994. (www.wras.co.uk)

WRAS Information & Guidance Note No. 9-02-05 *Marking and identification of pipework for reclaimed (greywater) systems*. WRAS, 1999. (www.wras.co.uk)

Market Transformation Programme. *Rainwater and greywater: technical and economic feasibility*. MTP, 2007.

Market Transformation Programme. *Rainwater and greywater: a guide for specifiers*. MTP, 2007.

Market Transformation Programme. *Rainwater and greywater: review of water quality standards and recommendations for the UK*. MTP, 2007.

NHS D08 *National Health Service Model Engineering Specifications Thermostatic Mixing Valves (Healthcare Premises)*. NHS.

BRE Information paper IP14/03 *Preventing hot water scalding in bathrooms: using TMVs*.

Food Standards Agency Code of Practice *Food hygiene – a guide for businesses*. (www.food.gov.uk)

English Heritage publication *Building Regulations and Historic Buildings, 2002 (revised 2004)*, (www.english-heritage.org.uk)

European Council Directive 89/106/EEC, *The Construction Products Directive*.

European Council Directive 93/68/EEC, *The CE Marking Directive*.

The Code for Sustainable Homes, December 2006. (www.planningportal.gov.uk)

HSC publication *Legionnaires' Disease: Control of Legionella Bacteria in Water Systems. Approved code of practice and guidance. L8*, Health and Safety Commission 2000. ISBN 0717617726

CIBSE Commissioning Code M: *Commissioning Management*, CIBSE, 2003. ISBN 1 90328 733 2

Health and Safety Commission, *Workplace health, safety and welfare, Approved code of practice*, HMSO 1992.

CIBSE Guide G: *Public health engineering*, CIBSE, 2004. ISBN 1 90328 742 1

CIBSE Domestic Building Services Panel: *Solar heating design and installation guide*, 2007. ISBN 978 1 90328 784 2

CLG publication, *The Water Efficiency Calculator for new dwellings*, BRE Global Ltd, September 2009. ISBN 978 1 4098 1827 4

Standards referred to

6.1

BS 65:1991

Specification for vitrified clay pipes, fittings and ducts, also flexible mechanical joints for use solely with surface water pipes and fittings. AMD 8622 1995.

BS EN 274:1993

Sanitary tapware. Waste fittings for basins, bidets and baths. General technical specifications. (Withdrawn and superseded by BS EN 274-1:2002 Waste fittings for sanitary appliances. Requirements. AMD 14959 2004. BS EN 274-2:2002 Waste fitting for sanitary appliances. Test methods. AMD 14957 2004. BS EN 274-3:2002 Waste fittings for sanitary appliances. Quality control. AMD 14958 2004.)

BS EN 295-1:1991

Vitrified clay pipes and fittings and pipe joints for drains and sewers. Test requirements. AMD 9290 1996, AMD 9429 1995, AMD 10621 1999.

BS EN 295-2:1991

Vitrified clay pipes and fittings and pipe joints for drains and sewers. Quality control and sampling. AMD 10620 1999.

BS EN 295-3:1991

Vitrified clay pipes and fittings and pipe joints for drains and sewers. Test methods. AMD 10357 1999.

BS EN 295-6:1996

Vitrified clay pipes and fittings and pipe joints for drains and sewers. Requirements for vitrified clay manholes. AMD 15279 2004.

BS 416-1:1990

Discharge and ventilating pipes and fittings, sand-cast or spun in cast iron. Specification for spigot and socket systems.

BS 437:1978

Specification for cast iron spigot and socket drain pipes and fittings. AMD 5877 1988.

BS EN 598:1995

Ductile iron pipes, fittings, accessories and their joints for sewerage applications. Requirements and test methods.

BS EN 752-1:1996

Drain and sewer systems outside buildings. Generalities and definitions.

BS EN 752-2:1997

Drain and sewer systems outside buildings. Performance requirements.

BS EN 752-3:1997

Drain and sewer systems outside buildings. Planning. AMD 10984 2000, AMD 13038 2001.

BS EN 752-4:1998

Drain and sewer systems outside buildings. Hydraulic design and environmental considerations. AMD 15442 2005.

BS EN 752-5:1998

Drain and sewer systems outside buildings. Rehabilitation.

BS EN 752-6:1998

Drain and sewer systems outside buildings. Pumping installations.

BS EN 752-7:1998

Drain and sewer systems outside buildings. Maintenance and operations. AMD 10440 1999.

BS EN 877:1999

Cast iron pipes and fittings, their joints and accessories for the evacuation of water from buildings. Requirements, test methods and quality assurance.

BS 882:1992

Specification for aggregates from natural sources for concrete. AMD 13579 2002. (Withdrawn and superseded by BS EN 1260:2002 Aggregates for concrete. AMD 15333 2004.)

BS EN 1057:1996

Copper and copper alloys. Seamless, round copper tubes for water and gas in sanitary and heating applications.

BS EN 1091:1997

Vacuum sewerage systems outside buildings.

BS EN 1254-1:1998

Copper and copper alloys. Plumbing fittings. Fittings with ends for capillary soldering or capillary brazing to copper tubes. AMD 10099 1998.

BS EN 1254-2:1998

Copper and copper alloys. Plumbing fittings. Fittings with compression ends for use with copper tubes.

BS EN 1254-3:1998

Copper and copper alloys. Plumbing fittings. Fittings with compression ends for use with plastics pipes.

BS EN 1254-4:1998

Copper and copper alloys. Plumbing fittings. Fittings combining other end connections with capillary or compression ends. AMD 10750 1999.

BS EN 1254-5:1998

Copper and copper alloys. Plumbing fittings. Fittings with short ends for capillary brazing to copper tubes. AMD 10100 1998.

BS EN 1295-1:1998

Structural design of buried pipelines under various conditions of loading. General requirements.

BS EN 1329-1:2000

Plastics piping systems for soil and waste discharge (low and high temperature) within the building structure. Unplasticized polyvinyl chloride (PVC-U). Specifications for pipes, fittings and the system.

BS EN 1401-1:1998

Plastics piping systems for non-pressure underground drainage and sewerage. Unplasticized poly(vinylchloride) (PVC-U). Specifications for pipes, fittings and the system. AMD 13794 2002.

BS EN 1451-1:2000

Plastics piping systems for soil and waste discharge (low and high temperature) within the building structure. Polypropylene (PP). Specifications for pipes, fittings and the system. AMD 13819 2002.

BS EN 1455-1:2000

Plastics piping systems for soil and waste (low and high temperature) within the building structure. Acrylonitrile-butadienestyrene (ABS). Specifications for pipes, fittings and the system. AMD 13818 2002.

BS EN 1519-1:2000

Plastics piping systems for soil and waste discharge (low and high temperature) within the building structure. Polyethylene (PE). Specifications for pipes, fittings and the system. AMD 13817 2002.

BS EN 1565-1:2000

Plastics piping systems for soil and waste discharge (low and high temperature) within the building structure. Styrene copolymer blends (SAN + PVC). Specifications for pipes, fittings and the system. AMD 13816 2002.

BS EN 1566-1:2000

Plastics piping systems for soil and waste discharge (low and high temperature) within the building structure. Chlorinated poly (vinyl chloride) (PVC-C). specification for pipes, fittings and the system. AMD 13815 2002.

BS EN 1610:1998

Construction and testing of drains and sewers.

BS EN 1671:1997

Pressure sewerage systems outside buildings.

BS EN 1825-1:2004

Installations for separation of grease. Principles of design, performance and testing, marking and quality control.

BS EN 1825-2:2002

Installations for separation of grease. Selection of nominal size, installation and maintenance.

BS EN 1852-1:1998

Plastics piping systems for non-pressure underground drainage and sewerage. Polypropylene (PP). Specifications for pipes, fittings and the system. AMD 14514 2003.

BS 3868:1995

Specification for prefabricated drainage stack units in galvanized steel.

BS 3921:1985

Specification for clay bricks.

(Current but partially superseded by BS EN 772-3:1998 Method of test for masonry units. Determination of net volume and percentage of voids of clay masonry units by hydrostatic weighing. BS EN 772-7:1998 Method of test for masonry units. Determination of water absorption of clay masonry damp proof course units by boiling in water.)

BS 5255:1989

Specification for thermo-plastics waste pipe and fittings.

(Current but partially superseded by BS EN 1329-1:2000 Plastics piping systems for soil and waste discharge (low and high temperature) within the building structure. Unplasticized poly(vinyl chloride) (PVC-U). Specifications for pipes, fittings and the system. BS EN 1455-1:2000 Plastics piping systems for soil and waste (low and high temperature) within the building structure. Acrylonitrile-butadiene-styrene (ABS). Specifications for pipes, fittings and the system. AMD 13818 2002. BS EN 1519-1:2000 Plastics piping systems for soil and waste discharge (low and high temperature) within the building structure. Polyethylene (PE). Specifications for pipes, fittings and the system. AMD 13817 2002. BS EN 1565-1:2000 Plastics piping systems for soil and waste discharge (low and high temperature) within the building structure. Styrene copolymer blends (SAN + PVC). Specifications for pipes, fittings and the system. AMD 13816 2002. BS EN 1566-1:2000 Plastics piping systems for soil and waste discharge (low and high temperature) within the building structure. Chlorinated poly(vinyl chloride) (PVC-C). Specification for pipes, fittings and the system. AMD 13815 2002.)

BS 5911-2:1982

Precast concrete pipes, fittings and ancillary products. Specification for inspection chambers. AMD 5146 1986, AMD 8077 1994, AMD 11030 2001. (Withdrawn and superseded by BS 5911-4:2002 Concrete pipes and ancillary concrete products. Specification for unreinforced and reinforced concrete inspection chambers. AMD 15038 2004. BS EN 1917:2002 Concrete manholes and inspection chambers, unreinforced, steel fibre and reinforced. AMD 15289 2004.)

BS 5911-100:1988

Precast concrete pipes, fittings and ancillary products. Specification for unreinforced and reinforced pipes and fittings with flexible joints. AMD 6269 1989, AMD 7588 1993. (Withdrawn and superseded by BS 5911-1:2002 Concrete pipes and ancillary concrete products. Specification for unreinforced and reinforced concrete pipes (including jacking pipes) and fittings with flexible joints. AMD 15040 2004. BS EN 1916:2002 Concrete pipes and fittings, unreinforced, steel fibre and reinforced. AMD 15288 2004.)

BS 5911-120:1989

Precast concrete pipes, fittings and ancillary products. Specification for reinforced jacking pipes with flexible joints. AMD 9020 1996. (Withdrawn and superseded by BS 5911-1:2002 Concrete pipes and ancillary concrete products. Specification for unreinforced and reinforced concrete pipes (including jacking pipes) and fittings with flexible joints. AMD 15040 2004. BS EN 1916:2002 Concrete pipes and fittings, unreinforced, steel fibre and reinforced. AMD 15288 2004.)

BS 5911-200:1994

Precast concrete pipes, fittings and ancillary products. Specification for unreinforced and reinforced manholes and soakaways of circular cross section. AMD 11031 2001, AMD 13205 2001. (Withdrawn and superseded by BS 5911-3:2002 Concrete pipes and ancillary concrete products. Specification for unreinforced and reinforced concrete manholes and soakaways. AMD 15039 2004. BS EN 1917:2002 Concrete manholes and inspection chambers, unreinforced, steel fibre and reinforced. AMD 15289 2004.)

BS 6798:2000

Specification for installation of gas-fired hot water boilers of rated input not exceeding 70kW. AMD 14908 2005.

BS 7158:2001

Plastics inspection chambers for drains and sewers. Specification. (Current but superseded by BS EN 13598-1:2003 Plastics piping systems for non-pressure underground drainage and sewerage. Unplasticized poly(vinyl chloride) (PVC-U), polypropylene (PP) and polyethylene (PE). Specifications for ancillary fittings including shallow inspection chambers.)

BS 8000-13:1989

Workmanship on building sites. Code of practice for above ground drainage and sanitary appliances.

BS 8000-14:1989

Workmanship on building sites. Code of practice for below ground drainage.

BS 8110-1:1997

Structural use of concrete. Code of practice for design and construction. AMD 9882 1998, AMD 13468 2002, AMD 16016 2005.

BS EN 12050-1:2001

Wastewater lifting plants for buildings and sites. Principles of construction and testing. Lifting plants for wastewater containing faecal matter.

BS EN 12050-2:2001

Wastewater lifting plants for buildings and sites. Principles of construction and testing. Lifting plants for faecal-free wastewater.

BS EN 12050-3:2001

Wastewater lifting plants for buildings and sites. Principles of construction and testing. Lifting plants for wastewater containing faecal matter for limited applications.

BS EN 12056-1:2000

Gravity drainage systems inside buildings. General and performance requirements.

BS EN 12056-2:2000

Gravity drainage systems inside buildings. Sanitary pipework, layout and calculation.

BS EN 12056-3:2000

Gravity drainage systems inside buildings. Roof drainage, layout and calculation.

BS EN 12056-4:2000

Gravity drainage systems inside buildings. Wastewater lifting plants. Layout and calculation.

BS EN 12056-5:2000

Gravity drainage systems inside buildings. Installation and testing, instructions for operation, maintenance and use.

BS EN 12109:1999

Vacuum drainage systems inside buildings.

BS EN 12380:2002

Air admittance valves for drainage systems. Requirements, test methods and valuation of conformity.

BS EN 13564-1:2002

Anti-flooding devices for buildings. Quality assurance.

BS EN 13564-2:2002

Anti-flooding devices for buildings. Test methods.

BS EN 13564-3:2002

Anti-flooding devices for buildings. Quality assurance.

6.2

BS 5328-1:1997

Concrete. Guide to specifying concrete. AMD 10364 1999, AMD 13876, AMD 14163 2002. (Withdrawn and superseded by BS 8500-1:2002 Concrete. Complementary British Standard to BS EN 206-1. Method of specifying and guidance for the specifier. AMD 14639 2003. BS 8500-2:2002 Concrete. Complementary British Standard to BS EN 206-1. Specification for constituent materials and concrete. AMD 14640 2003. BS EN 206-1:2000 Concrete. Specification, performance, production and conformity. AMD 13189 2001, AMD 14857 2004, AMD 15359 2004, AMD 15406 2004.)

BS 5328-2:1997

Concrete. Methods for specifying concrete mixes. AMD 9691 1997, AMD 10365 1999, AMD 10612 1999, AMD 13877. (Withdrawn and superseded by BS 8500-1:2002 Concrete. Complementary British Standard to BS EN 206-1. Method of specifying and guidance for the specifier. AMD 14639 2003. BS 8500-2:2002 Concrete. Complementary British Standard to BS EN 206-1. Specification for constituent materials and concrete. AMD 14640 2003. BS EN 206-1:2000 Concrete. Specification, performance, production and conformity. AMD 13189 2001, AMD 14857 2004, AMD 15359 2004, AMD 15406 2004.)

BS 5328-3:1990

Concrete. Specification for the procedures to be used in producing and transporting concrete. AMD 6927 1991, AMD 7176 1992, AMD 9312, AMD 10366 1999, AMD 10708 1999, AMD 13878 2002. (Withdrawn and superseded by BS 8500-1:2002 Concrete. Complementary British Standard to BS EN 206-1. Method of specifying and guidance for the specifier. AMD 14639 2003. BS 8500-2:2002 Concrete. Complementary British Standard to BS EN 206-1. Specification for constituent materials and concrete. AMD 14640 2003. BS EN 206-1:2000 Concrete. Specification, performance, production and conformity. AMD 13189 2001, AMD 14857 2004, AMD 15359 2004, AMD 15406 2004.)

BS 5328-4:1990

Concrete. Specification for the procedures to be used in sampling, testing and assessing compliance of concrete. AMD 6928 1991, AMD 8760 1995, AMD 9313, AMD 10367 1999, AMD 10611 1999. (Withdrawn and superseded by BS 8500-1:2002 Concrete. Complementary British Standard to BS EN 206-1. Method of specifying and guidance for the specifier. AMD 14639 2003. BS 8500-2:2002 Concrete. Complementary British Standard to BS EN 206-1. Specification for constituent materials and concrete. AMD 14640 2003. BS EN 206-1:2000 Concrete. Specification, performance, production and conformity. AMD 13189 2001, AMD 14857 2004, AMD 15359 2004, AMD 15406 2004.)

BS 6297:1983

Code of practice for design and installation of small sewage treatment works and cesspools. AMD 1650 1990.

BS 7781:1994

Procedure for type testing of small biological domestic wastewater treatment plants.

BS EN 12566-1:2000

Small wastewater treatment plants less than 50 PE. Part Prefabricated septic tanks. AMD 14918 2004.

6.3**BS EN 752-1:1996**

Drain and sewer systems outside buildings. Generalities and definitions.

BS EN 752-2:1997

Drain and sewer systems outside buildings. Performance requirements.

BS EN 752-3:1997

Drain and sewer systems outside buildings. Planning. AMD 10984 2000, AMD 13038 2001.

BS EN 752-4:1998

Drain and sewer systems outside buildings. Hydraulic design and environmental considerations. AMD 15442 2005.

BS EN 752-5:1998

Drain and sewer systems outside buildings. Rehabilitation.

BS EN 752-6:1998

Drain and sewer systems outside buildings. Pumping installations.

BS EN 752-7:1998

Drain and sewer systems outside buildings. Maintenance and operations. AMD 10440 1999.

BS EN 858:2001

Separator systems for light liquids (e.g. oil and petrol). Principles of product design, performance and testing, making and quality control. AMD 15525 2005.

BS EN 858-2:2003

Separator systems for light liquids (e.g. oil and petrol). Selection of nominal size, installation, operation and maintenance.

BS EN 1295-1:1998

Structural design of buried pipelines under various conditions of loading. General requirements.

BS EN 1610:1998

Construction and testing of drains and sewers.

BS EN 12056-1:2000

Gravity drainage systems inside buildings. General and performance requirements.

BS EN 12056-2:2000

Gravity drainage systems inside buildings. Sanitary pipework, layout and calculation.

BS EN 12056-3:2000

Gravity drainage systems inside buildings. Roof drainage, layout and calculation.

BS EN 12056-4:2000

Gravity drainage systems inside buildings. Wastewater lifting plants. Layout and calculation.

BS EN 12056-5:2000

Gravity drainage systems inside buildings. Installation and testing, instructions for operation, maintenance and use.

Other publications referred to

6.1

Water Regulations Advisory Scheme (WRAS)

Information and Guidance Note 09-02-05 *Marking and identification of pipe work for reclaimed and (grey water) systems*, 1999.

Information and Guidance Note 09-02-04 *Reclaimed water systems. Information about installing, modifying or maintaining reclaimed water systems*, 1999.

WRAS documents available from WRAS, Fern Close, Pen-y-Fan Industrial Estate, Oakdale, Gwent, NP11 3EH, Tel 01495 248454, Fax 01495 249235, email info@wras.co.uk. Available to download from www.wras.co.uk/

Water Research Council (WRc)

Sewers for adoption. A design and construction guide for developers, 5th edition, 2001. ISBN 1 89892 043 5

6.2

BRE

Good Building Guide GBG 42 Part 1 *Reed beds: application and specification*, 2000. ISBN 1 86081 436 0

Good Building Guide GBG 42 Part 1 *Reed beds: design, construction*, 2000. ISBN 1 86081 437 9

Environment Agency

Pollution Prevention Guidelines PPG 4 *Disposal of sewage where no mains drainage is available*, 2001. Available to download from www.netregs.gov.uk

6.3

BRE

Digest 365 *Soakaway design*, 1991 (minor revisions 2003). ISBN 1 86081 604 5

CIRIA

Publication C522 *Sustainable urban drainage systems – design manual for England and Wales*, 2000. ISBN 0 86017 522 7

Report 156 *Infiltration drainage – Manual of good practice*, 1996. ISBN 0 86017 457 3

Environment Agency

Pollution Prevention Guidelines PPG 3 *Use and design of oil separators in surface water drainage systems*, 2000. Available to download from www.netregs.gov.uk

H R Wallingford

Report SR 463 *Performance of syphonic drainage systems for roof gutters*.

Department for Communities and Local Government

Planning Policy Guidance 14, Development on unstable land – Annex 1: *Landslides and planning*, 1996. ISBN 0 11753 259 2. Available to download from www.communities.gov.uk

Water Regulations Advisory Scheme (WRAS)

Information and Guidance Note 09-02-05 *Marking and identification of pipe work for reclaimed and (greywater) systems*, 1999.

Information and Guidance Note 09-02-04 *Reclaimed water systems. Information about installing, modifying or maintaining reclaimed water systems*, 1999.

