

THE **Safe** USE OF Woodworking Machinery

**APPROVED CODE OF
PRACTICE AND GUIDANCE**

ACoP 9

Health & Safety at Work (Jersey) Law, 1989





The safe use of woodworking machinery

ACoP 9 2011



Health and Safety at Work Inspectorate,

Social Security Department, P.O. Box 55, Philip Le Feuvre House, La Motte Street, St. Helier, Jersey JE4 8PE

Tel: 01534 447300 Fax: 01534 873791 E-mail: hsi@gov.je Website: www.gov.je/hsi



The Safe Use of Woodworking Machinery

Approved Code of Practice

Notice of Approval

This Code of Practice, entitled "The Safe Use of Woodworking Machinery", has been approved by the Minister for Social Security under Article 10 of the Health and Safety at Work (Jersey) Law, 1989, ("the Law").

The Code provides practical guidance for all persons who have duties under Part 2 of the Law and are involved with the use of woodworking machinery at work.

ACoP 9

This Code of Practice shall come into force on 1 July 2011.



Deputy I Gorst

Minister for Social Security

9 March 2011

Acknowledgement

The assistance in the preparation of this publication given by Jon Gibson of Didac and Doug Taylor-Fitch of Highlands College is gratefully acknowledged.

Contents

Notice of Approval	
Preface	1
Interpretation	5
Introduction and Application	7
Training and Supervision of Operators	9
Medical Standards	16
Working Environment	19
Machinery Safety - General	22
Machinery Safety - Specific	
Circular Saw Benches	27
Manually Operated Cross-Cut Saws	31
Hand-Fed Surface Planing Machines	35
Thickness Planing Machines	38
Vertical Spindle Moulding Machines	40
Narrow Band Saws	45
Single-End Tenoning Machines	47
Health - Wood Dust	51
Health - Noise	53
Further Information	56
Appendix - Training Records	

Preface

This Approved Code of Practice (ACoP) gives practical guidance on the safe use of woodworking machinery. With the exception of hand held portable machines, the ACoP applies to woodworking machinery used in all working environments for processing, cutting and shaping timber and composite materials. The ACoP covers the provision of information and training as well as aspects of guarding and other hazards encountered in the woodworking industry such as noise and dust. It is not an exhaustive guide on the guarding and safe operation of woodworking machinery but a practical guide as to how the legal requirements for health and safety may be met. The guidance gives further advice on the requirements of the ACoP. Although hand held portable machines are excluded from this ACoP, many of the principles in machine guarding and work practices set out in the ACoP can be applied to their use.

In Jersey, woodworking machinery is used extensively throughout many workplaces. The use of woodworking machinery can be very dangerous and has resulted in operators, including both self employed individuals and employees, suffering serious accidents, generally to their hands and frequently resulting in a permanent disability.

Such injuries cause suffering for operators and can often lead to the business incurring heavy costs.

There is a high level of risk from using woodworking machinery; the operation of machines relies on high speed sharp cutting edges, which in many cases are necessarily exposed to enable the machining process to take place. In addition, woodworking is probably the only industry where many machines are still hand fed, resulting in the hands of the operator being constantly exposed to danger; familiarity can give a false sense of security.

There is also a high risk of injury from the ejection of work pieces from the machine. No two pieces of wood are the same, each piece behaving differently when machined or shaped during the production process. Knots and natural changes in the direction of the grain can give rise to snatching and kickback of the workpiece.

The risks from the operation of woodworking machinery need to be controlled. This ACoP and guidance will help in meeting the legal requirements and reduce operators from being exposed to unnecessary risks.

Management of woodworking operations

There are a few simple measures which can be taken to prevent accidents involving woodworking machinery. Examples of these are:

- Provision of adequate training for operators, supervisors and managers;
- Using the appropriate equipment for the job to be done;
- Laying out premises in such a way as to ensure that the machinery can be used safely;
- Effective guarding for each type of woodworking machine and ensuring safe systems of work;
- Ensuring that machinery and premises are maintained properly.

Preface

This publication contains the Approved Code of Practice (ACoP) together with guidance issued by the Health and Safety Inspectorate. For ease of reference, the paragraphs which are identified as part of the ACoP are highlighted with this background:



The guidance, in normal type, contains advice on best practice: the text of 'common problems' is included in **brown** type, with the accompanying 'common solutions' in **green** type.

The ACoP has been approved by the Minister for Social Security under Article 10 of the Law. If you follow the guidance you will be doing enough to comply with the Law in respect of those specific matters to which the ACoP refers. You may use alternative methods to those set out in the ACoP in order to comply with the Law. However, the ACoP has a special legal status. If you are prosecuted for a breach of the Law, and it is proved that you did not follow the relevant provisions of the ACoP, you will need to show that you have complied with the Law in some other way or the Court will find you at fault.

Health and Safety Inspectors seek to secure compliance with the Law and may refer to the ACoP and guidance as illustrating good practice.

Who should read this publication?

This ACoP and guidance is relevant to everyone with responsibility for the safe operation of woodworking machinery; for example, employers, managers, supervisors and operators, including those assisting operators. Others involved with woodworking machinery, such as health and safety representatives, may also find it useful.

The Law

Employers have a duty under health and safety law to ensure, so far as is reasonably practicable, the health, safety and welfare of their employees and others who may be affected by their undertaking. The main legislation applying to woodworking machinery is:

The Health and Safety at Work (Jersey) Law, 1989

The Health and Safety at Work (Jersey) Law, 1989, sets out the framework for dealing with health and safety issues by the States of Jersey, the Minister for Social Security and the Health & Safety Inspectorate, who are responsible for enforcement of the Law. The Law also states, under Part 2, the general duties of all persons involved with work activities.

Part 2 contains Articles 3 to 8:

Article 3 sets out the employer's duty to his employees. This requires every employer to ensure, so far as is reasonably practicable, the health, safety and welfare of his employees. Article 3 (2) goes on to give examples of the extent of that duty and includes:

- The provision and maintenance of plant and systems of work that are, so far as is reasonably practicable, safe and without risks to health;
- Arrangements for ensuring, so far as is reasonably practicable, safety and absence of risks to health in connection with the use, handling, storage and transport of articles and substances;
- The provision of such information, instruction, training and supervision as is necessary to ensure, so far as is reasonably practicable, the health and safety at work of their employees;
- So far as is reasonably practicable as regards any place of work under the employer's control, the maintenance of it in a condition that is safe and without risks to health and the provision and maintenance of access to and egress from it that are safe and without such risks;
- The provision and maintenance of a working environment for their employees that is, so far as is reasonably practicable, safe, without risks to health, and adequate as regards facilities and arrangements for their welfare at work.

Article 3 (3) requires all employers with 5 or more employees to prepare a written health and safety policy document and bring this to the attention of their employees. The policy is required to include the identification and assessment of significant risks and how they are to be addressed.

The duties of employees are set out in Article 4. They are required to take reasonable care of themselves and of other people who may be affected by the way they work. Employees must also co-operate with any legal requirements imposed upon their employer, such as the wearing and use of personal protective equipment.

Article 5 requires employers to take into account the effect of their work on others, including the general public. The self-employed also have to take into consideration the manner in which they carry out their work in respect of both themselves and others.

Article 6 places duties on persons who have control of premises used as a place of work, but do not have employees working on the premises, or possibly no employees at all.

Article 7 sets out the duties on designers, manufacturers, importers and suppliers. They must also play their part in ensuring health and safety issues are taken into account. This is an important area in ensuring that health and safety has been considered at the initial stages and continued through to the end user.

Finally, Article 8 requires that no person shall intentionally or recklessly interfere with, or misuse, anything provided in the interests of health, safety or welfare required by Law.

Safeguarding of Workers (Machinery and Woodworking Machines) (Jersey) Regulations, 1967

It is intended that Regulation 6 of these Regulations will be revoked following the introduction of this ACoP. Regulation 6 is considered to be outdated and does not reflect current safety standards for the use of woodworking machinery. The remaining Regulations will remain in force:

Regulation 4 provides for the guarding of prime movers;

Regulation 5 requires steps to be taken to ensure that the risks from transmission machinery are controlled;

Regulation 8 requires guarding to be provided to reduce the risk from flying particles ejected from machinery;

Regulation 12 sets out the duties of employees operating machinery;

Regulation 13 provides for notices to be displayed, setting out the duty under Regulation 12.

The Electricity at Work (Jersey) Regulations, 1983

These Regulations set out safety standards for the safe use of electricity at work. The Regulations are set out as goal setting standards, requiring all aspects of an electrical installation to be safe:

Regulation 5 refers to the need to ensure that all parts of the electrical installation are designed, constructed and maintained to ensure that the installation is safe;

Regulation 8 requires all electrical conductors to be protected;

Regulation 12 sets out the need for electrical connections to be suitably constructed;

Regulation 14 requires a means of cutting off and isolating the electrical supply;

Regulation 19 provides for first aid notices to be erected where the electrical supply is over 250 volts.

More detailed advice on these legal requirements is available in guidance published by the Health and Safety at Work Inspectorate.

Interpretation

For the purpose of this ACoP, unless the context otherwise requires:

Operator: the person who is operating or assisting in the use of a machine.

Young person: any person who has not yet reached the age of 18.

Use: any activity involving machinery including starting, stopping, programming, setting, transporting, repairing, modifying, maintaining, servicing and cleaning and assisting/taking off.

Prime mover: an engine, motor or other appliance which provides mechanical energy derived from electricity, the combustion of fuel or other source.

Transmission machinery: any shaft, wheel, drum, pulley, system of fast and loose pulleys, gearing, coupling, clutch, driving belt, chain, rope, band or other device by which the motion of a prime mover is transmitted to or received by any machine or appliance.

Rotary & reciprocating movements: all machines operate by rotating or reciprocating motion, or by a combination of these motions. Reciprocating movement is back-and-forth or up-and-down motion. Rotary cutting and shearing mechanisms, rotating material, flywheels, shaft ends, and spindles all rotate. Rotating action is hazardous regardless of the speed, size, or surface finish of the moving part.

In-running nip points: in-running nip points occur whenever rotating or reciprocating parts of a machine move toward each other in close proximity to a fixed part of the machine. Nip points include locations where drive belts approach the pulleys or gears, or where rotating parts are in close proximity to stationary parts.

Guard: provides protection to persons from injury. Types include fixed, adjustable and protection devices. A guard can either act:

- Independent of the operation of the machine. It is then only effective when it is in the closed position for a movable guard, or securely held in place as a fixed guard; or
- In conjunction with an interlocking device which prevents operation of the machine unless the guard is in position.

Kick back: when material being fed into the machine is ejected back towards the operator.

Introduction and Application

1. The ACoP sets out minimum standards to control risks from the use of woodworking machinery. The ACoP provides practical guidance on:

- Training and supervision of operators;
- Medical standards for operators;
- Guarding standards for woodworking machines; and
- Measures to control health risks arising from the use of woodworking machines.

2. Whilst the ACoP applies to the use of all woodworking machinery, except for hand held portable machines, specific guidance is provided on the use of the following types of machinery due to the high risk or frequency of accidents that occur from their use:

Circular Saw Benches – used for straight sawing of wood and composite materials. The type of machines to which this specific guidance applies include Circular Ripsaw Machines, Dimension Saw Machines and Panel Sawing Machines.

Manually Operated Cross Cut Saws – used for sawing across the grain of the wood and composite materials. The type of machines to which this specific guidance applies include Radial Arm, Travelling Head and Chop Sawing Machines.

Hand-Fed Surface Planing Machines – used for planing the face and edge of wood square to each other.

Thickness Planing Machines – used to plane wood to width and thickness.

Verticle Spindle Moulding Machines – used for moulding and shaping the edges of wood.

Narrow Band Saws – used for cutting straight and irregular shaped wood and composite materials.

Single-End Tenoning Machines – used to form projections (tenons) on wood.

Training and Supervision of Operators

3. Every employer must ensure that all persons who use woodworking machinery have received adequate training for the purpose of health and safety, including training in the methods which may be adopted when using the machine, any risks which such use may entail and precautions to be taken.
4. Every employer must ensure that any of their employees who supervise or manage the use of woodworking machinery, has received adequate training for the purpose of health and safety, including training in the methods which may be adopted to use the machine, any risks which such use may entail and precautions to be taken.
5. Without thorough and systematic training in safe working practices, both for those who work at woodworking machines and those who have the responsibility to supervise them, serious accidents will happen. This section gives advice to employers and others on how the legal requirements for training and supervision can be fulfilled.
6. The advice applies to all users (including apprentices, novices and experienced users) and can be used when taking on new staff and for assessing the training needs of existing employees/workers.
7. People may work at a woodworking machine as part of their training, but they should be under the close supervision of someone who has a thorough knowledge and experience of safe working practices and safe operation of the machine. Passing on bad habits and short cuts to trainees creates the potential for yet more accidents.
8. Supervisors have a legal duty to co-operate with their employer in providing necessary supervision for health and safety. Their job is not limited to producing a good quality product. Supervisors are a vital link in the chain for effective management of health and safety.
9. Good supervisors lead by example; they get good results and develop a motivated, safety conscious workforce.
10. Supervisors are often expected to be management's 'eyes and ears' on the shop floor, but investigations in the woodworking industry have shown that supervisors are often unaware of the full range of responsibilities they have as part of the management team. They are also paid to supervise - and this includes supervising for safety.
11. Supervisors must be informed of their responsibilities and know how to carry them out.

Common Problems

12. There are a number of problem areas to consider when training and supervising woodworking machinists:

- Non-authorized operators - No one should be allowed to work at a woodworking machine unless they have demonstrated competence;

Training and Supervision of Operators

- Young persons - Young persons are in a special position and warrant special consideration; they are often unwilling to ask questions, fearing to expose their own inexperience. Even when they have been trained, young people tend to need further supervision to make sure that they do not act irresponsibly or take short cuts which put themselves and others at risk;
- Incorrect selection of supervisors and operators;
- Supervisors not recognising the extent of their line management responsibility for the health and safety of employees;
- Although being experienced woodworking machinists, individuals, appointed as supervisors, not being trained in their role as a supervisor;
- Supervisors repeating bad habits learned from their own training.

Common Solutions

13. The solutions for dealing with training needs are as follows:

- Confirmation in writing by an authorised person that the machine operator has demonstrated competence through a staged assessment process;
- Considered and careful training being provided to a young person operating a machine, including continued support;
- Correct selection of supervisors, trainers and operators;
- Supervision until the trainee has displayed consistent levels of safe working practices;
- Provision of suitable training (including both initial and refresher training) which may be through external training, in-house training or a combination of both.

Authorisation to Operate Woodworking Machines through Assessment

- 14.** No one should be allowed to work at a woodworking machine unless they have demonstrated competence based on an assessment carried out by a supervisor or trainer, who should not only be familiar with the machining process but also with the risks and the safe working practices that are used.
- 15.** Assessment is carried out in two stages: first to identify the training needs of the individual and second to measure the success of the training that has been given. An initial assessment should be carried out for all people changing jobs within the company and new employees or those new to wood-machining.
- 16.** Existing staff that use woodworking machines should not be overlooked although identifying the training needs of experienced employees can pose particular problems.

Training and Supervision of Operators

17. Assessment should test competence in the following areas, all of which are essential to safe working:

- Machine selection: the ability to say ‘this is the wrong machine for this operation. It could be done more safely on . . .’;
- Purpose and adjustment of guards and safeguards;
- Knowledge of those operations prohibited on that machine without additional safeguards being provided;
- Selection and use of safety devices such as push-sticks, jigs, holders etc.;
- Practical understanding of guarding arrangements; for example, the function and setting of the riving knife on a circular bench saw, the adjustment of the top guard on a circular saw or the bridge guard on a surface planing machine. The appropriate use of guards, stops and jigs on a spindle moulder;
- Safe working practices including feeding, setting, cleaning, taking off and proper work support;
- The nature of material and the hazards produced, including kickback, snatching and health hazards from types of dust.

18. It is advisable to make and keep a written record of all assessments. Operators who are found to be competent should be authorised in writing by a responsible person such as a partner, director or member of senior management. The authorisation should list those machines and operations for which authorisation is given and it should be made clear to the operator that other machines should not be used until authorisation is given. A copy of the authorisation should be given to the operator for their personal record. Examples of suitable records for assessment and authorisation are shown in the Appendix to this ACoP.

Young Persons

19. Young persons are often exposed to risks to their health and safety when using work equipment as a consequence of their immaturity, lack of experience or awareness of existing or potential risks. ‘Young Person’ means any person who has not yet reached the age of 18. Therefore, young persons should not be allowed to use woodworking machinery, unless they have the necessary maturity and competence, and completed appropriate training.

20. During training, young persons may operate woodworking machinery providing they are adequately supervised. The completion of training and demonstration of competence by a young person is only part of the assessment required. The supervisor will also need to assess how mature the trainee is and whether they can work safely without putting themselves or others at risk. Adequate supervision should, therefore, continue to be provided after training if a young person is considered not to be sufficiently mature.

21. Induction training is of particular importance to young people because of their relative immaturity and unfamiliarity with the working environment.

Training and Supervision of Operators

Selection of Supervisors, Trainers and Operators

- 22.** The selection of supervisors and trainers is central to any successful training scheme. They must be competent in the operation of the machines on which training is to be given and they must be able to communicate easily and have the necessary technical understanding and knowledge of the legal requirements.
- 23.** Supervision needs to be carried out by people who are experienced, have been trained and know the extent of their responsibilities. Appropriate supervision may be indicated by:
- Supervisors understanding that they are a vital link in providing a safe workplace and are expected to supervise for safety, as well as for quality and quantity of output. Management support is required to help a supervisor do this;
 - Supervisors being aware of the extent of their health and safety responsibilities and how they link in with the responsibilities of operators and managers. The supervisor's job description and the company health and safety policy should indicate how to do this;
 - Supervisors being provided with appropriate training to enable them to supervise effectively.
- 24.** Potential machine operators should be selected with care. Those selected for training should be reliable and have the ability to do the job in a responsible manner.

Level of Supervision during Training of Operatives

- 25.** It is difficult to define precisely what represents an adequate level of supervision as it will vary throughout the training process. Initially, supervision should be continuous and on a one-to-one basis, with gradual relaxation as the trainee becomes more competent. As each new operation or training element is introduced, the level of supervision will need to rise again, reducing gradually to a more general level only when the trainee has demonstrated competence by consistent adoption of safe working practices.

Training

- 26.** Training may take a number of forms: external, in-house, a combination of both and refresher training. In all cases a training record should be maintained and periodically reviewed for each operator.
- 27.** External courses: care should be taken to ensure that the class of machine and type of work which the operator is expected to do have been covered by the course. It is very important to establish that training has been received over the full range of work to be carried out. For example, some training modules on the vertical spindle moulding machine include only straight work; stopped work and curved work require additional skills and further training will be needed.

Training and Supervision of Operators

28. In-house training should consist of three elements:

- General - the basic skills and knowledge common to all woodworking machines. This will include aspects of 'good housekeeping' and awareness of danger appropriate to someone 'taking-off', plus knowledge of the relevant legislation;
- Machine Specific - the basic skill in the operation of the machine, including the position and function of emergency stops; basic safety rules related to the operation of a machine or class of machines; the use and adjustment of guards and safety devices;
- Familiarisation - on-the-job operation under close supervision.

29. The various stages of training may be combined or integrated. Where the general and machine-specific training is given externally at a college or training centre, it is important that familiarisation training is carried out in the workplace under close supervision. Those delivering in-house training should hold appropriate up to date skills and knowledge to ensure effective/safe delivery. If in-house training is carried out in conjunction with an external course, then the standard of supervision should be the same as for familiarisation training.

30. Many training providers, accredited by training bodies, are able to design and deliver training programmes tailored to the needs of a particular company. Training can take place at a training centre or within the workshop environment. In the latter case, there is the advantage that the training can be related to the machine, models and individual processes in use within the organisation. However, production needs must never be allowed to prejudice the quality of the training given or the level of supervision provided.

31. Didac Ltd is one of the leading UK national health and safety training providers for the furniture and timber industries. The Woodwise Training Scheme, which has been developed by Didac, provides a route to gaining or, for experienced operators, demonstrating, the minimum level of skills required for operating woodworking machinery. The Scheme's certification programme consists of online learning modules with a practical test of competence. In Jersey, Highlands College has been appointed by Didac as a training centre for the delivery of the Woodwise Scheme.

32. Whichever approach is taken to provide training for operators, the training scheme selected should cover the following general and machine specific areas:

General

- The importance of good housekeeping.
- Avoiding horseplay.
- Isolation procedures before adjusting or maintaining the machine.
- Awareness of common dangers like 'taking off', 'dropping-on' and 'kickback'.
- How to report faults.

Training and Supervision of Operators

Machine Specific

- The main causes of accidents at the machine.
- The tasks it is designed for.
- What procedures require additional guards or jigs etc.
- Safe working practices.
- How to use and adjust guards.
- How to use protection devices and appliances.
- How to select and fit tooling correctly.
- Stopping procedures, including the use of brakes where fitted.
- Personal protective equipment requirements, e.g., hearing/ eye protection.
- Health risks and how to control them, e.g., dust extraction.
- Job-specific (familiarisation).

- 33.** Refresher training is appropriate for trained and experienced operators of woodworking machines and is particularly important if they have not operated a particular class of machine for some time, or, if the method of control or operation of the machine has been significantly changed. It is recommended that refresher training is carried out every 3 to 5 years.

Further reading

Health and Safety Executive Woodworking Leaflet 'Supervising for safety in woodworking'

Medical Standards

34. A person shall not be authorised to operate machinery unless they are fit to do so. No person should be selected to operate a machine unless they have the physical and mental attributes necessary to operate the machine in a safe manner.
35. Employees should report to their employers any serious illness, accident or other circumstance which is clearly liable to affect their fitness, and any medically certified unfitness.
36. Any employee whose ability to operate machinery appears to be temporarily impaired by alcohol or drugs (including prescribed), should be considered unfit while that impairment lasts.

Common Problems

37. If a person is unwell, and so unfit to work, there is a risk to them, their colleagues and their surroundings, in allowing them to use machinery.
38. Being unwell could lead to a greater chance of having an accident whilst using machinery. Taking prescribed drugs or suffering from a virus can delay reaction times and affect operator ability to work efficiently.
39. Health hazards can also have an increased effect on an operator who has a flu virus, for example, as he or she will be more susceptible to noise and wood dust inhalation.

Common Solutions

40. Employers should assess the fitness of persons they intend to authorise, and should have arrangements for regular monitoring of the person's fitness to continue working on machines. Therefore, before making any such authorisation, an individual assessment should be conducted. This would involve confirmation of good general health, vision, hearing and any specific medical disorders which might affect a person's ability to operate the machinery safely.
41. The fitness of operators to use machines should always be judged on an individual basis. Fitness should relate to the ability of persons to operate particular machines safely. The assessment should take into account any temporary impairment; for example, the effects on the operator of a virus infection.
42. Where persons continue to be employed to operate machinery they should be re-assessed at appropriate intervals. These intervals will depend on individual circumstances, but should not be more than five years. Re-assessment should also be undertaken following serious/ significant illness or injury and where prolonged or repeated absences from work are attributable to illness or injury.
43. In addition, all reasonable requests by the person operating machinery, for re-assessment, should be met. Re-assessment should also be undertaken if the employer has any doubt as to the continuing fitness of the individual to operate machinery. Supervisors and managers would be expected to use their judgement and experience in determining whether an individual operator was impaired by alcohol or drugs.

Medical Standards

It is not expected that medical examinations or instruments will need to be used in this situation, although an opinion from a second person may sometimes be useful. However, it remains for management to make the decision whether the individual should be permitted to continue.

44. An operator may not use machinery when taking medication that is known to affect their judgement, such as drugs that cause dizziness, drowsiness or blurred vision.
45. Health checks of operators should be carried out. Since wood dust causes asthma, it is important to pick up any health affects early. This can be done using health surveillance. For most woods, a low level of health surveillance is sufficient. This consists of a questionnaire administered before anyone starts work where they are exposed to wood dust, and then repeated annually.
46. A higher level of health surveillance of operators should be carried out by a medical practitioner where there are particular chemicals and toxins being used that have a significant effect on the body. These include:
 - Exposure to substances known to cause occupational asthma and respiratory sensitises; for example, red cedar dusts;
 - Exposure to substances known to cause severe dermatitis and skin sensitisation; for example, organic solvent-based wood preservatives. Skin inspections should be carried out at regular intervals by a responsible person.
47. An operator should report to his employer any illness or health issues that may affect his ability to carry out his work.

Further reading

Health and Safety Executive Woodworking Information Sheet 6 'COSHH and the woodworking industries'

Health and Safety Executive Woodworking Information Sheet 30 'Toxic woods'

Health and Safety Executive Publication 'Health Surveillance at Work'

Working Environment

48. Adequate space must be provided around each woodworking machine, taking into account the work to be carried out on the machine, in order to enable the operator to use the machine safely.
49. The floor around a woodworking machine must be level and kept free from any obstructions.
50. Adequate lighting, either through natural or artificial means, must be provided to enable operators of woodworking machines to have a clear view of the woodworking machine and activity which is intended to be carried out. Adequate lighting must also be provided in all workshops or other areas where woodworking machinery is used.
51. The areas where woodworking machinery is to be used must be adequately heated to enable the woodworking operation to be carried out safely. A minimum temperature of 16°C should be provided in a workplace where machinery is used, 10°C for sawmills. Where it is impracticable to heat the entire workshop or area, localised heating should be provided adjacent to the working area.
52. Adequate welfare arrangements, with hot and cold water, soap and towels, must be provided. Operators must be encouraged to adopt high standards of personal hygiene.

Common Problems

53. Where the environment in which a machine is operated is cramped, has uneven or obstructed flooring, poor lighting or is inadequately heated, the operator's attention will be distracted, resulting in a higher risk of injury.
54. Woodworking machines incorporate cutters or blades which run at very high speeds. Poor lighting can result in operators who approach the machine not being aware that the cutters or blades are still in motion.
55. The operation of woodworking machinery under fluorescent lighting can, because of the potential stroboscopic effect, lead operators to believe that the machine has come to rest.

Common Solutions

56. Consideration must be given to the layout of the workshop or area where the machine is to be used for it to be used safely for the work intended. Electricity supply cables should either be routed above head height or should be set into the floor in such a way as to prevent tripping hazards. Polished floors should be avoided.
57. Suitable lighting must be provided to enable the operator to have a clear view of the workpiece, the cutters and the operating controls of the machine. Adequate lighting must also be provided in the area around the machine. The lighting must be positioned or shaded to avoid glare and reflections from work benches or other shiny surfaces.
58. Adequate heating must be provided in the area where woodworking machinery is used. Where it is impracticable to heat the entire workplace, radiant heaters can be provided near to the working area.

Working Environment

- 59.** The floor should have a slip resistant surface, be level and kept in good repair and free from loose materials such as chippings or waste wood. All spillages should be promptly cleared away to avoid the risk of slipping.

Machinery Safety - General

60. Woodworking machines must only be used for activities for which they were designed.
61. Woodworking machines must be kept well maintained.
62. Each woodworking machine must be adequately supported to ensure that the machine is stable when in use.
63. Each woodworking machine must be provided with a means of isolation from the electrical supply or other source of power. The isolator should be clearly marked and conveniently sited.
64. Each woodworking machine must be provided with starting and stopping controls within easy reach of the operating position.
65. Braking devices must be fitted to woodworking machinery where risk assessment shows that it is necessary, in order to control the risks during rundown of all machines.
66. Access to all dangerous areas of power transmission machinery of a woodworking machine must be prevented by the fitting of suitable guards.
67. All dangerous parts of a woodworking machine must be effectively guarded to the extent that is practicable.
68. All guards must be suitable for the purpose for which they are intended, of good construction, adequate strength and maintained in efficient working order.
69. All tooling, including cutters and saw blades, fitted to woodworking machines, must be suitable for the activity to be carried out and must be maintained in good condition.
70. Where practicable, to further reduce the risks from using a woodworking machine, suitable devices such as power feed units, jigs, holders and push sticks or push blocks should be used in conjunction with the guarding of the machine.
71. Effective measures, including the use of guarding and protection devices, should be taken to control the risks of material, or parts of the machine or tooling from being ejected from the machine.

Common Problems

72. Machinery used for carrying out operations for which it is not designed may not be able to be guarded effectively to ensure the safety of operators.
73. Movement of the machine due to instability can result in the operator being injured as a result of coming into contact with the high speed cutters or saw blade.
74. If the machine has controls that are not within easy reach, the operator's attention might be diverted from the hazards posed from the dangerous areas of the machine.

Machinery Safety - General

75. Operators, or other persons performing service or maintenance on machinery and equipment, may be exposed to injuries from the unexpected start-up of the machinery or equipment.
76. Operators can be injured through contact with dangerous parts of the transmission machinery:
 - Rotating parts and shafts can catch hair or clothing of the operator;
 - Operators can be caught and crushed by reciprocating movement of the machine when a moving part approaches or crosses a fixed part of the machine;
 - Operators may be caught between or drawn into in-running nip points.
77. Operators can be injured if the guarding of the machine is not properly adjusted or maintained.
78. Operators can be struck by a projecting bolt or key.
79. The work piece may be hurled back at the user. Hazards due to kickbacks are most likely when there is a lack of safeguards, such as riving knives or anti-kickback fingers.
80. The cutting action of the equipment may expose employees to splinters and chips that are flung from the machines.
81. Using the wrong tool on a cutter head or using a tool at a higher speed than it was designed to operate at, can cause tool breakage.
82. If a cutter or blade is damaged, the work piece may be snatched and pull the operator's hands into the machine.
83. Operators can be injured if they attempt to clean the machine or remove a piece of wood after the machine has been turned off, but the cutters or saw blades are still running down.
84. Operators can be injured if their hands get too close to the tool, particularly when working on small work pieces.

Common Solutions

85. Machines must be adequately supported or secured in place to prevent any movement which could affect the safety of the operator.
86. Machines should be capable of being isolated from their power supply. Isolation controls should be clearly identified and capable of being 'locked off' to enable maintenance work to be carried out on the machine with the power isolated.
87. The controls of machines should be clearly marked and easily accessible by the operator.

Guards

88. Guards should be provided to woodworking machines to reduce operators being exposed to dangerous parts of the machine.

Machinery Safety - General

89. Guards must be robust and not create a hazard in themselves. Good guarding should:

- Prevent any part of an operator or other persons body from making contact with dangerous moving parts;
- Not be able to be easily removed or tampered with by an operator;
- Be made of durable material that can withstand the conditions of normal use;
- Be constructed to provide protection from objects, material, etc. falling into moving parts of the machinery;
- Not create a new hazard, such as a shear point, a jagged edge, or an unfinished surface that could cause a laceration;
- Always be fitted in place before use of the machine. Guards should be checked before the machine is used to make sure they are securely in place and in good condition. Defective or missing guards should be reported immediately;
- Be kept well maintained to ensure that they operate properly.

90. Woodworking equipment and guards should be regularly cleaned and maintained.

91. Blades must be kept in good condition with knives and cutting heads kept sharp, properly adjusted and secured. Any cracked or damaged blades must be removed from service.

92. If the machine cannot be guarded in order to complete a job, it is a clear indication that it is not the right machine to use.

Braking Devices

93. Braking devices to reduce the rundown time of cutters and saw blades should be fitted to:

- Circular saw benches;
- Powered and hand-fed cross-cut saws;
- Single-end and double-end tenoning machines;
- Combined machines incorporating a circular saw and/or tenoning attachment;
- Narrow band saws;
- Re-saws;
- Vertical spindle moulding machines;
- Hand-fed routing machines;
- Thicknessing machines;
- Surface planing machines;
- Planing/ thicknessing machines.

Machinery Safety - General

94. Braking devices are not considered necessary when:

- Machines have a rundown time of 10 seconds or less;
- The effect of braking could be detrimental to the integrity of the machinery.

Working Practices

- 95.** Machinery should only be used for the purpose for which it is designed.
- 96.** Machines should only be used within the rated capacity specified by the machine manufacturer.
- 97.** Only the correct tools specifically designed for use with a machine should be used. For example, only blades and cutter heads that are intended for use on a particular machine should be used.
- 98.** The use of chip limitation tooling reduces the risk of kickback and must be used on hand-fed machines, including spindle moulders and single-end tenoning machines.
- 99.** Machines should never be left running unattended. Operators must never leave a machine that has been turned off but is still running down.
- 100.** Operators should never clean a saw using only their hands or while the machine is running.
- 101.** Operators must be provided with push sticks or other hand tools so that their hands are away from cutters or saw blades when they work on small pieces of timber.
- 102.** Work pieces that have checks, splits, cracks or knots which could result in the work piece breaking up when machined, should not be used.
- 103.** Glued joints should be allowed to dry before working on work pieces.
- 104.** Deep cuts should be avoided as they increase the likelihood of kickbacks.
- 105.** Operators should not wear loose clothing or have untied long hair when using machinery, as loose clothing or long hair can be easily caught up in rotating parts.
- 106.** Operators should use appropriate personal protective equipment.
- 107.** Whenever possible, operators should stand back or to the side once the workpiece has been put through, to avoid injuries from kickback and flying splinters.

Machinery Safety - Specific

Circular Saw Benches

108. Circular saw benches are used for straight sawing. They are also known as table saws, bench saws, rip saws, dimension saws and panel saws.



Traditional Rip Sawing Machine

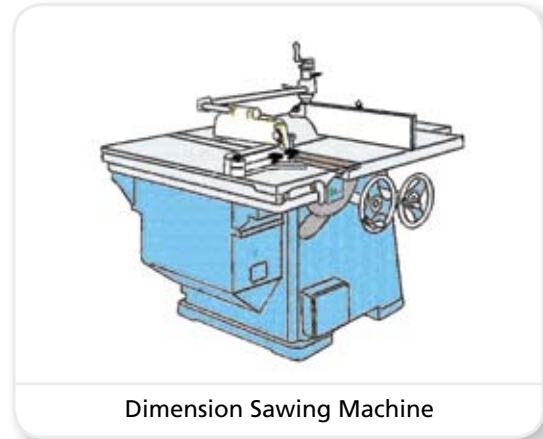

Dimension Sawing Machine

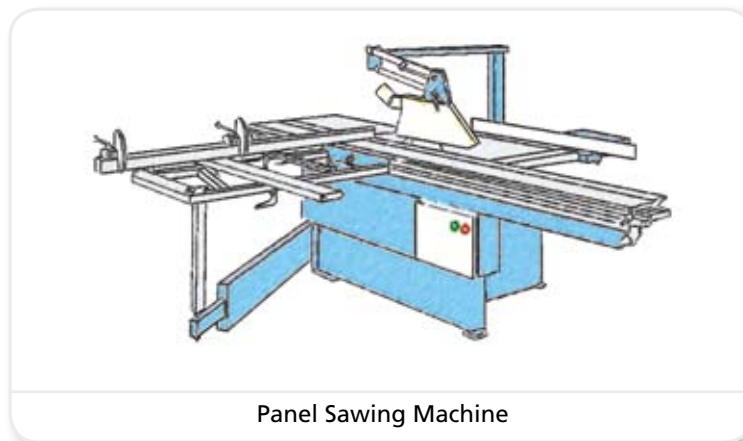

Panel Sawing Machine

109. Access to the saw blade from beneath the saw table should be prevented by fixed guarding.

110. The top of the saw blade, above the work-piece being cut, should be fully enclosed by a guard. Either,

a) the guard and mounting shall be arranged so that the guard will automatically adjust itself to the thickness of, and remain in contact with, the work piece being cut, but not offer any considerable resistance to insertion of the workpiece or to the passage of the workpiece being sawn; or

b) when an automatic guard is not available, the guard and mounting shall be arranged so that the guard can be adjusted to the thickness of, and remain just above, the work-piece being cut. The guard must not offer any considerable resistance to insertion of the workpiece or to the passage of the workpiece being sawn.

Machinery Safety - Specific

- 111.** The top guard must be fitted with suitable extraction points.
- 112.** A rigid riving knife shall be provided to prevent material from pinching the saw or being thrown back on the operator. The riving knife should have a chamfered leading edge and be thicker than the body of the saw blade but thinner than the saw kerf. The riving knife should be set accurately in line with the saw blade and shaped so that the inner edge follows, so far as practicable, the contour of the largest saw blade designed to be used on the machine.
- 113.** Adequate support, suitable for the work being carried out should be provided to the work piece, through the provision of a rip fence and, where necessary, extension tables.
- 114.** Circular saws should be fitted with a braking device which brings the blade to rest within 10 seconds.
- 115.** The minimum diameter of the saw blade must not be less than 60% of the largest saw blade diameter that can be fitted to the machine. The diameter of the smallest saw blade that can be safely used should be marked on the machine.

Common Problems

- 116.** The operator may come into contact with the blade under the table if it is not effectively guarded or enclosed.
- 117.** Injuries can occur if an operator's hands slip when feeding the workpiece into the saw or if the operator holds their hands too close to the blades while cutting. The operator can also be injured when removing scrap or finished pieces from the table.
- 118.** Kickbacks can result if the blade height is not correct or if the blade is not properly maintained. Kickbacks can also occur if safe-guards are not used, if poor-quality timber is cut, or if there are incorrect settings of the riving knife/ fence.
- 119.** Wood chips, splinters, and broken saw teeth may be thrown by the cutting action of the blade.

Common Solutions

- 120.** Always guard the portion of the blade below the table. Operators must be protected from possible contact with dangerous parts of the machine when reaching under the table.
- 121.** The saw blade above the table should be enclosed, as far as is practicable, with a guard. This guard can either be self-adjusted or manually placed. The guard must adjust to the thickness of the material being cut and either remain in contact with it if self adjusting, or stay as close as possible to the workpiece.
- 122.** A riving knife should be fitted to the machine to prevent material from pinching the saw or kicking back during ripping.

Machinery Safety - Specific

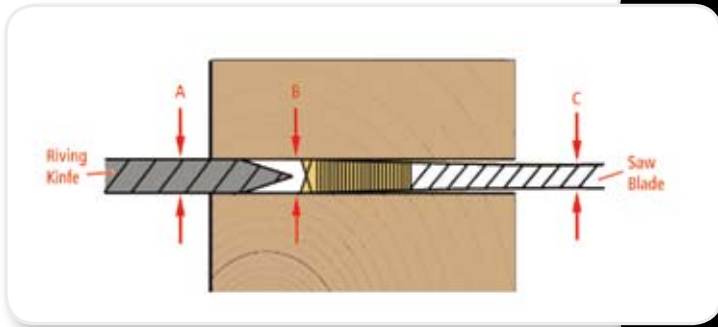

Key:

A is riving knife thickness

B is kerf of saw (width of cut)

C is thickness of saw blade body

A to be greater than C but less than B

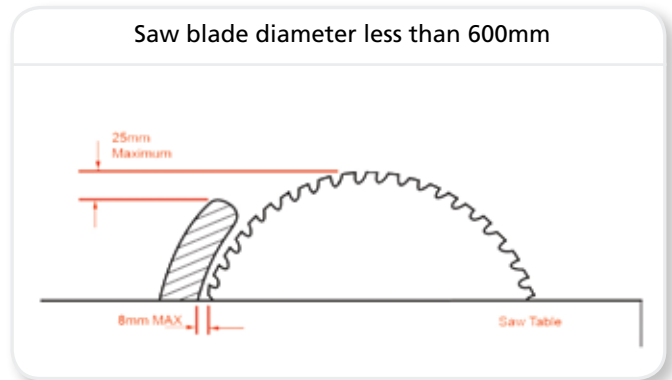
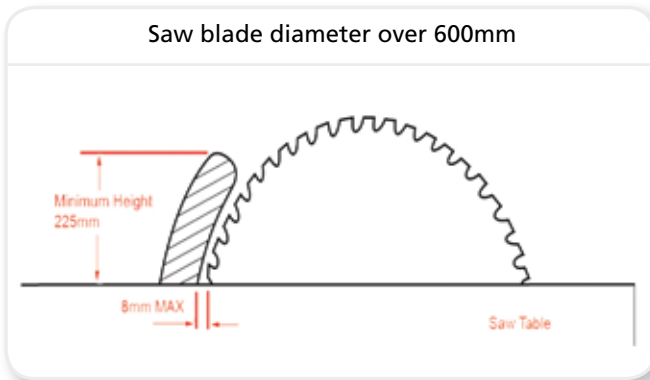

Position of riving knife

123. An appropriate saw blade should be fitted to the machine.

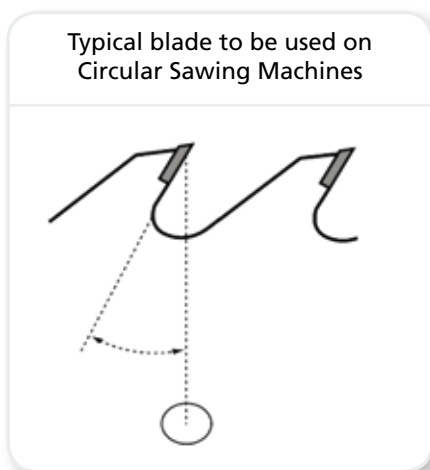

Positive Hook Angle

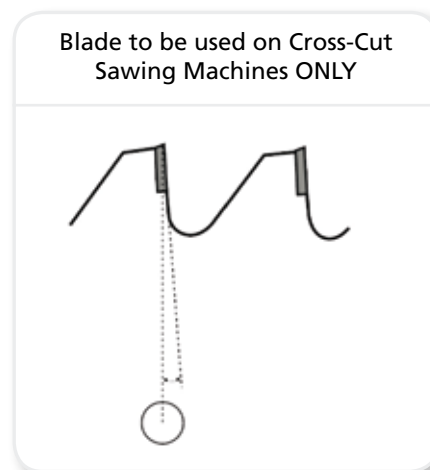

Negative Hook Angle

124. The machine should be operated only at the speed specified by the manufacturer.

Machinery Safety - Specific

- 125.** A rip fence should be used to guide and support the work piece to minimise the potential for kickback.

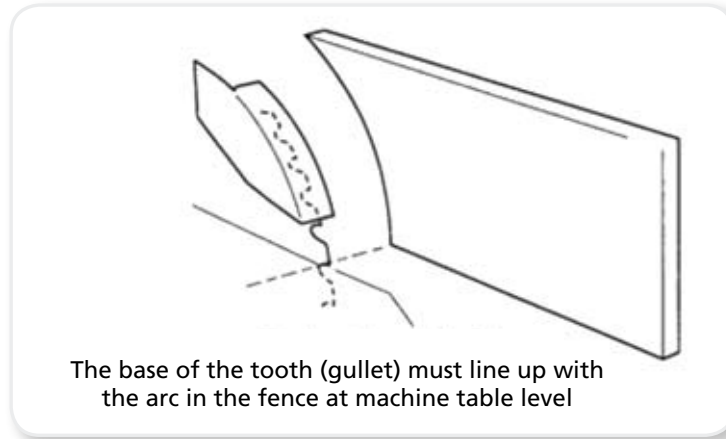

- 126.** When cutting timber, the end of the fence should be in line with the bottom of the gullets of the saw at table level, to prevent material becoming jammed between the blade and fence, which could result in kickback. When using a dimension saw for cutting manufactured boards, the end of the fence may be positioned past the gullet of the saw as manufactured boards do not distort the same way as timber and there is a greatly reduced chance of kickback.
- 127.** All parts of the workpiece should be adequately supported, including the cut and uncut ends, scrap and finished product.
- 128.** All saw blades should be round and balanced, cleaned of any gum and adhesive and kept sharp.
- 129.** Saw blades which are damaged or cracked should be removed from use.
- 130.** Sufficient clearance should be provided around the machine to ensure that the work piece is not obstructed. This is particularly important when ripping large sheet materials.
- 131.** Avoid cross-cutting long lengths of timber on table saws unless the timber is adequately supported. Without adequate support, considerable hand pressure is required close to the saw blade, and overhanging lengths of timber create a safety hazard to other people.
- 132.** Operators should stand to the side of the saw blade where ever possible to avoid injury due to kickback.
- 133.** Operators should be trained to keep their hands out of the line of cut of the saw blade.
- 134.** A push stick should be used when making any cut less than 300mm in length or when feeding the last 300mm of a longer cut.

Further reading

Health and Safety Executive Woodworking Information Sheet 16 'Circular saw benches - Safe working practices'

Manually Operated Cross-Cut Saws

135. Cross-cut saws are used for cutting across the workpiece. A manually operated cross-cut saw is one where the operator positions the workpiece up to the fence. The operator then pulls the blade to cut through the work piece and then returns the blade back to its rest position. This section is applicable to both horizontal-stroking machines, i.e. radial arm and travelling head, and down-stroking machines, i.e. mitre saws or sniper saws.

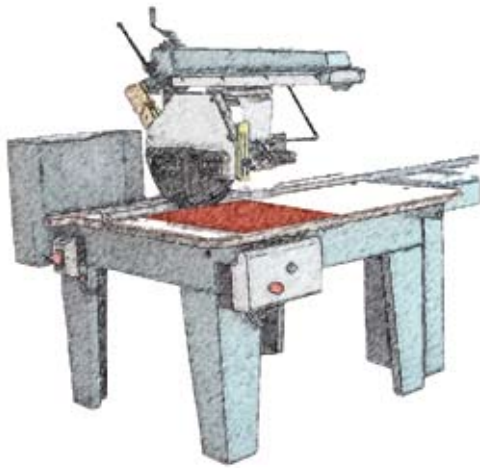

Radial Arm Cross-Cut

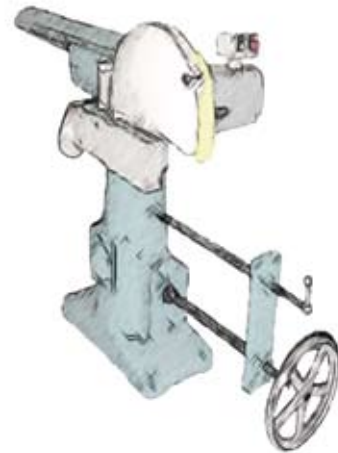

Radial Head Cross-Cut



Down Stroking Machine

Machinery Safety - Specific

- 136.** Each horizontal cross-cut saw shall be provided with a fixed hood guard that will completely enclose the upper half of the non cutting part of the saw blade and extend at least down to the saw spindle. The guarding of the machine must be such that when the saw blade is positioned in the rest position, access to the saw blade is restricted.
- 137.** An adjustable nose guard should be fitted to each horizontal cross-cut saw to prevent, as far as is practicable, contact with the front edge of the saw blade.
- 138.** The stroke of the saw blade of a horizontal cross-cut saw should be such that the nose guard does not extend beyond the edge of the work table.
- 139.** Each horizontal cross-cut saw must either be fitted with a device which automatically returns the machine to its safe rest position, or be fitted with an automatic braking device which stops the rotation of the saw spindle in 10 seconds or less.
- 140.** Each down-stroking cross-cut saw shall be provided with a fixed hood guard that will completely enclose the upper half of the non cutting part of the saw blade and extend at least down to the saw spindle.
- 141.** A self closing guard must be provided to each down-stroking cross-cut saw which prevents access to the cutting edge of the saw blade when the saw blade is returned to the rest position.
- 142.** The guarding to the cutting edge of the saw blade of a down-stroking cross-cut saw shall be such that only the minimum extent of the cutting edge is exposed when the workpiece is being cut.
- 143.** Adequate support, suitable for the work being carried out, should be provided to the work piece, through the provision of a fence and, where necessary, extension tables.

Common Problems

- 144.** The operator's hands can come into contact with the saw blade behind the work table, as they are bringing the saw towards the work piece, or when removing waste/ off cuts or finished work pieces from the table.
- 145.** Snatching of the work piece can occur if poor quality material is being cut, the blade is not the correct type, the depth of the blade is not correctly adjusted or the blade is not properly maintained.
- 146.** Wood chips, splinters, and broken saw teeth may be ejected by the cutting action of the blade.

Common Solutions

- 147.** The top half of the saw blade of a horizontal cross-cutting machine, extending down to at least the saw spindle, should be totally enclosed.

Machinery Safety - Specific

- 148.** Access to the cutting edge of a saw blade of a cross-cut machine should be restricted when the saw blade is at rest. This can be achieved by providing a saw housing into which the saw blade retreats when not in use, or side cover guards which automatically close to cover the edge of the saw blade as it is pushed back into the rest position.
- 149.** An adjustable nose guard should be fitted to a horizontal cross-cut machine to prevent contact with the front edge of the saw blade.

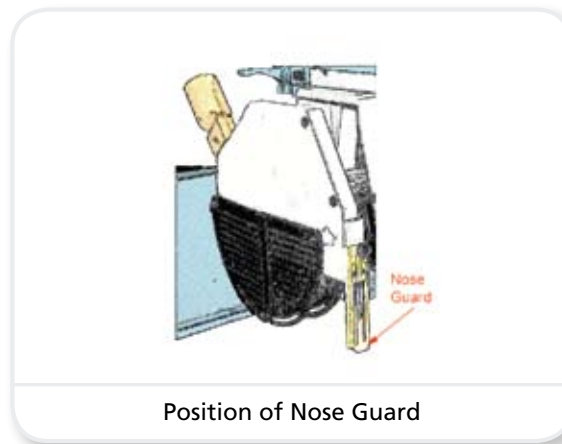

- 150.** Either the saw blade of a horizontal cross-cut machine should automatically retract into its rest position, or an automatic brake which stops the rotation of the saw blade within 10 seconds should be fitted to the machine.
- 151.** The cutting edge of a down-stroking cross-cut machine should be provided with a self-closing guard. There are two types of guard available, either a guard which opens progressively as the saw blade is lowered on the work piece, or the guard opens when it comes into contact with the workpiece and rests on the workpiece during the cutting operation.
- 152.** Only the appropriate type of blade for the cutting action required should be used.

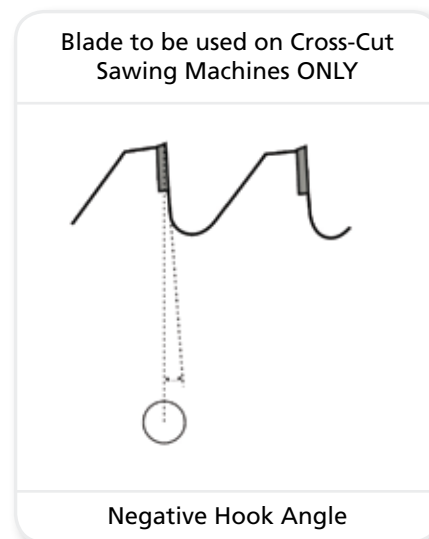
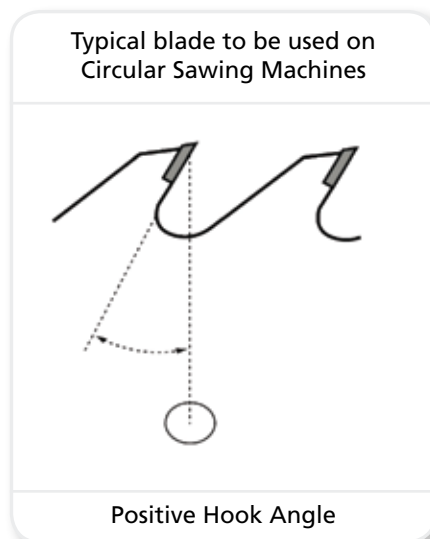

Machinery Safety - Specific

- 153. The machine should only be operated at the speed specified by the manufacturer.
- 154. The blade should be maintained in good condition and kept sharp. Any damaged or cracked saw blades should be removed from use.
- 155. The workpiece should be supported by being held securely against the fence in order to minimize the potential for kickback.
- 156. Sufficient space should be provided when cutting long lengths of material. All work pieces should be adequately supported throughout the cutting operation.
- 157. Operators should take particular care when cutting naturally bowed timber. The workpiece should be placed on the machine with the bow supported, i.e. against the bed or against the fence, to reduce the potential for the work piece to bind and snatch.

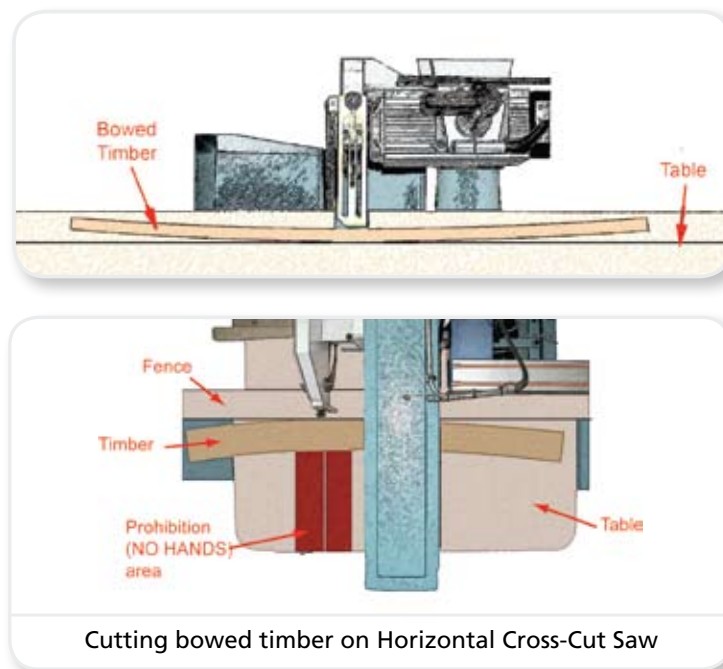

- 158. The fence should be high enough to support the size of the work piece being cut.
- 159. Ripping must not be carried out on a cross-cut saw, unless the machine has been designed to be used in this way, i.e. combination machine.
- 160. It is good practice to establish a 'no hands' (painted red) area on the work table which could, for example, be set at 150mm either side of the saw line. Operators should not hold the workpiece within this area during cutting.
- 161. The operator should use a work piece holder or jig when cutting small or narrow work pieces.

Further reading

Health and Safety Executive Woodworking Information Sheet 36 'Safe use of manually operated cross-cut saws'

Hand-Fed Surface Planing Machines

- 162.** A hand-fed planing machine is used for making flat surfaces and straight edges on timber by passing the work piece over a horizontal cutter head. The depth of the cut is achieved by adjusting the infeed table.

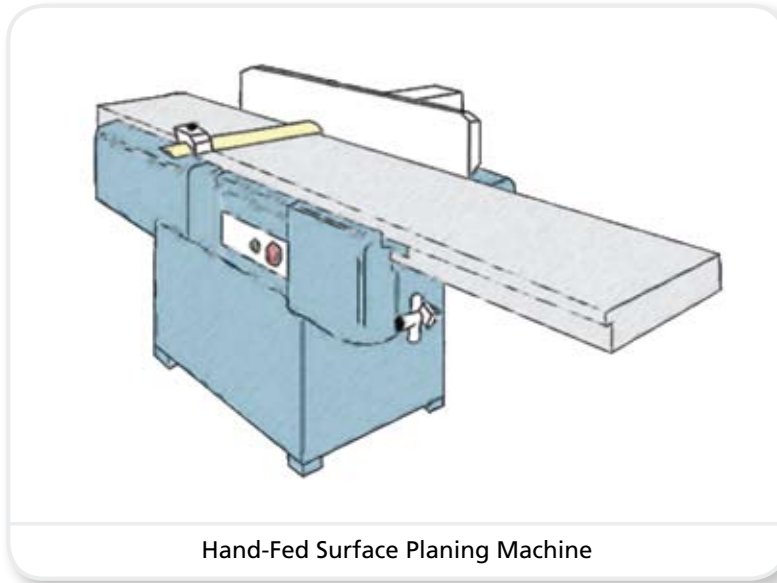

Hand-Fed Surface Planing Machine

- 163.** Every hand-fed planing machine must be fitted with a bridge guard that is strong and rigid, constructed so as to be capable of easy adjustment, both in a vertical and horizontal direction.
- 164.** The bridge guard must be capable of covering both the maximum length and at least the width of the diameter of the cutter block.
- 165.** The bridge guard must be mounted on the machine centrally over the cutter block and shall be so constructed and fitted as to prevent the guard from being accidentally displaced from that position.
- 166.** A rear bridge guard must be fitted to cover the cutter block behind the fence to have the same requirements as the main bridge guard.
- 167.** The table of every hand-fed planing machine should be so designed and constructed as to be capable of adjustment to make the clearances between the cutting circle of the cutting block, and the front edge of the feed and delivery tables, as small as is practicable. No overhand planing machine shall be used unless it has been first adjusted in this way.
- 168.** Only cylindrical cutter blocks should be used on hand-fed planing machines.
- 169.** Hand-fed planing machines should be provided with a suitable fence capable of providing support for the work-piece.

Machinery Safety - Specific

- 170.** Access by any person to any part of the cutting block of a hand-fed planing machine to the rear of the fence, should be prevented by the fitting of a suitable and easily adjustable guard.
- 171.** A suitable push block fitted with a pressure shoulder and hand grips should be provided on every planing machine and used if:
- the wider surface of any material that is 450 mm or less in length is being planed; and
 - the work cannot be done by passing the material under the guard.
- 172.** Hand-fed planing machines which have a run down time greater than 10 seconds must be fitted with a brake which brings the block to rest within 10 seconds.
- 173.** Rebating and chamfering must only be carried out on machines supplied prior to 1995 which are fitted with appropriate tunnel guards. All machines manufactured after 1995 are designed to prevent rebating and chamfering from being carried out on the machine.

Common Problems

- 174.** The operator's hands may come into contact with the cutting knives if guards are not used or adjusted correctly, or push blocks are not used.
- 175.** The work piece may be snatched by the cutting knives resulting in the operator's hands coming into contact with the cutting blades.
- 176.** The workpiece may be kicked back towards the operator when being fed into the machine.
- 177.** The cutting action of the machine may eject wood chips and splinters.

Common Solutions

- 178.** The bridge guard and fence should be strong and rigid, made from a material such as wood or aluminium, so that in the event of contact with the cutter block, neither the guard nor the cutter block will disintegrate.

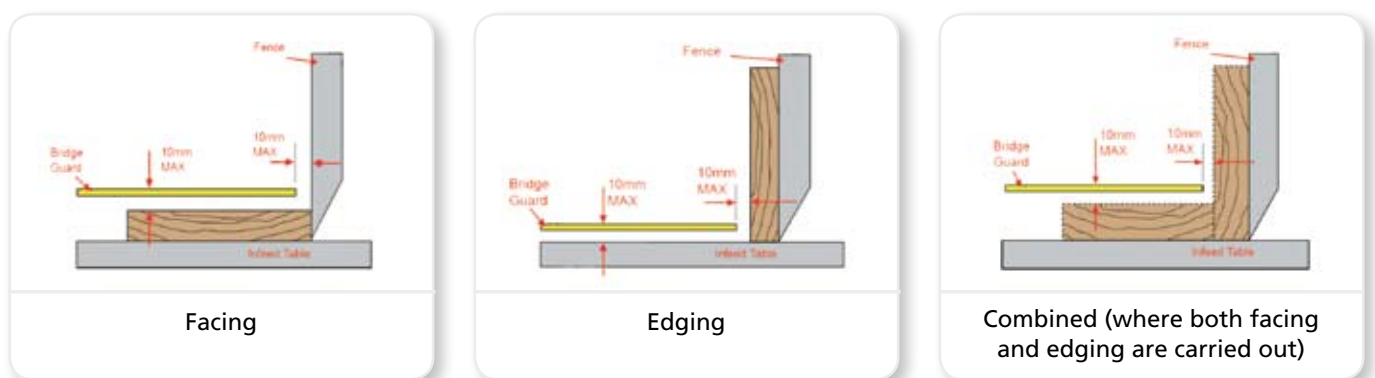

Position of bridge guard and fence

Machinery Safety - Specific

- 179.** Only cylindrical cutter blocks should be used on hand-fed planing machines. Knife projections should be kept to a minimum. On new machines (i.e. post 1995) a maximum cutter projection should be 1.1mm.
- 180.** The clearance distance between the circle and the lips of the infeed and outfeed tables should be as small as practicable, generally $3\text{ mm} \pm 2\text{ mm}$.

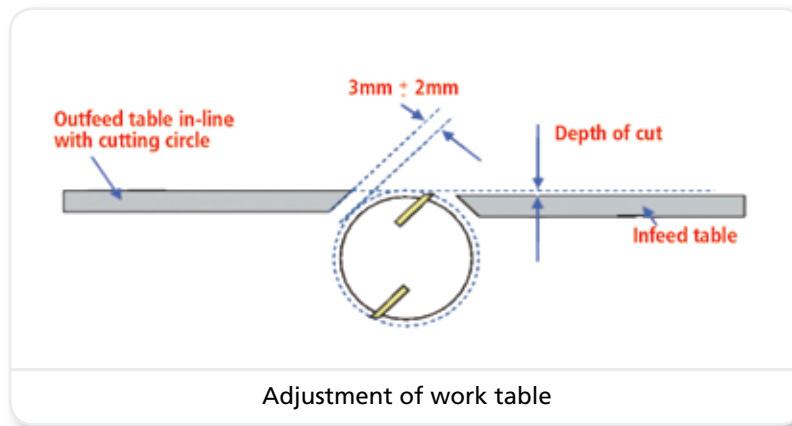

- 181.** The out-feed table height should never be below the top of the cutting block.
- 182.** All guards should be in position before trial cuts are made.
- 183.** The machine should be adjusted so that the clearance between the table and the head is as small as possible.
- 184.** Where possible, operators should use suitably constructed push blocks to minimise exposure to cutting blades.

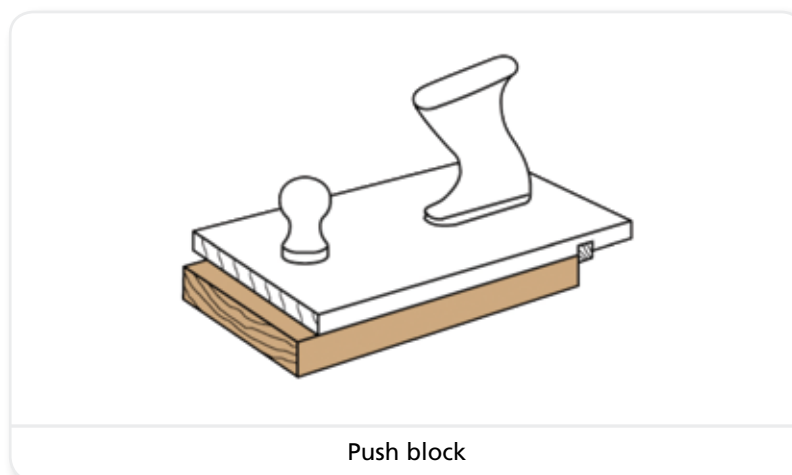

Further reading

Health and Safety Executive Woodworking Information Sheet 17 'Safe use of hand-fed planing machines'

Thickness Planing Machines

185. Thickness planers are used for sizing rough sawn or over size timber, after facing and edging on the surface planer, ready for subsequent machining or finishing.



Thickness Planing Machine

- 186.** Every thickness planer must be fitted with fixed guards to prevent access to the cutter area.
- 187.** Only cylindrical cutter blocks should be used on thickness planing machines.
- 188.** Thickness planing machines, which have a run down time greater than 10 seconds, must be fitted with a brake which brings the block to rest within 10 seconds.

Common Problems

- 189.** The work piece may be ejected back, towards the operator, when being fed into the machine.
- 190.** The cutting action of the machine may eject wood chips and splinters.

Machinery Safety - Specific

Common Solutions

- 191.** The machine should only be used for cutting material within the manufacturer's specified use.
- 192.** Where fitted, anti-kickback fingers and segmented rollers should be maintained and in good working order. Where anti-kickback fingers or segmented rollers are not fitted, only one piece of timber should be fed into the machine at a time. The minimum length of timber to be fed into the machine, and whether only one piece of timber should be fed into the machine at any one time, should be marked on the machine.

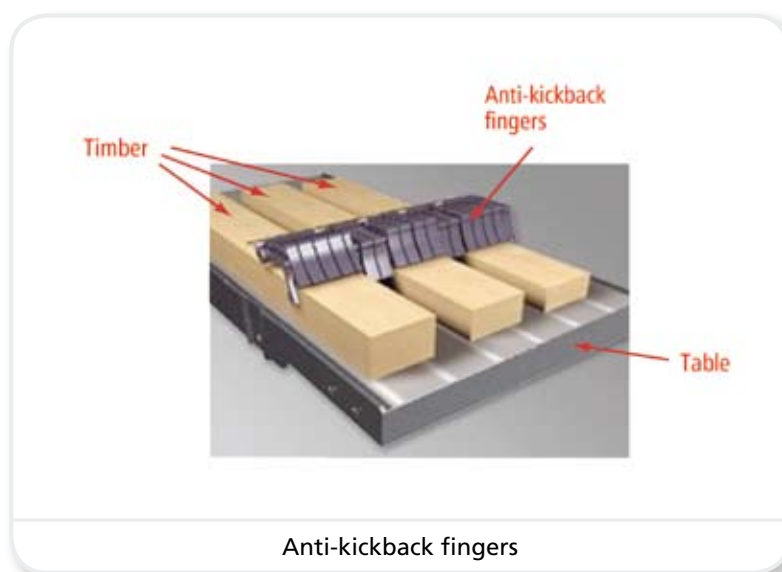

- 193.** Support rollers should be provided and used when working large lengths of material.
- 194.** The machine should not be used to remove an excessive amount of material in one cut.
- 195.** Operators should ensure that their hands are not placed within the feed opening to the machine.
- 196.** Operators should stand to one side when feeding material into the machine and never look into the feed of the machine.

Vertical Spindle Moulding Machines

- 197.** Vertical spindle moulding machines are used to mould the edges of material. The machining operation consists of feeding material against a vertical rotating cutter mounted on a spindle.



Vertical Spindle Moulding Machine

- 198.** Vertical spindle moulding machines must be fitted with guards, to the extent that is practicable, so as to prevent operators coming into contact with the spindle and the cutting head.
- 199.** When carrying out straight work a demountable power feed unit should be used wherever possible for feeding the workpiece into the machine.
- 200.** A push stick should be provided and used wherever necessary when feeding material into the machine so as to reduce the potential for the operator's hands to come into contact with the spindle and cutting head.
- 201.** Jigs or work holders and stops should be used where necessary to prevent the operator's hands from being in close proximity to the cutting head.
- 202.** Stopped work on a vertical spindle moulder must only be carried out when a suitable back stop is provided.
- 203.** Only limited cutting projection tooling should be used. The cutters should be secured to the cutting block so as to prevent them being ejected.
- 204.** A vertical spindle moulding machine must be fitted with a braking device that brings the cutting head to rest within 10 seconds.

Machinery Safety - Specific

Common Problems

- 205.** No single type of guard or safety device can deal adequately with the variety of work which can be done on these machines, requiring the operator to carefully consider and provide the best protection to suit the particular circumstances. The operator's hands can come into contact with the rotating cutter block if the selected guarding is inadequate.
- 206.** Cutters can dislodge from the cutter block if they are poorly fastened in the tool holder, if the wrong tool is used, or if the rotational speed of the machine is too high. Cutters may also be ejected if the cutter head is unbalanced.
- 207.** Kickback may be caused by poor-quality material, incorrect pressure or if incorrect tooling is used.

Common Solutions

- 208.** Only limited cutter projection tooling should be used. This type of tooling reduces the risk of kickback and the severity of injury (i.e., should the operator's hand contact the tool).

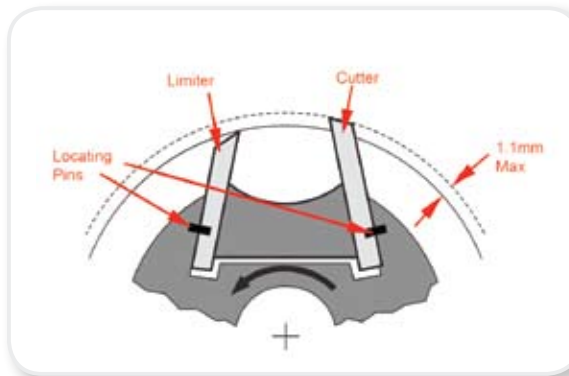

Limited cutter projection tooling

- 209.** Detachable cutters and limiters should be the correct thickness for the cutter block in which they are used; they should be capable of being mounted in such a way to prevent them being ejected.
- 210.** The cutters should be precision-ground to ensure that they are sharp and balanced to apply uniform pressure to the workpiece.
- 211.** It is essential that the selected rotational speed of the machine is appropriate for the tooling being used (the designed speed range should be marked on the cutter block) and the cutter blade project no more than 1.1mm over the limiter blade.
- 212.** Operators should be trained to listen for "chatter," which indicates that knives are out of balance.

Machinery Safety - Specific

- 213.** All tooling should meet a recognised standard, such as BS EN 847-1:2005, 'Tools for woodworking safety requirements' and permanently marked in accordance with the standard. Only tools marked MAN (meaning manual-feed) should be used on vertical spindle moulders, even if a demountable power feed unit is to be used.
- 214.** The cutters, cutter block and spindle behind the fence should be fully enclosed by a suitably designed guard which allows for the connection of dust exhaust outlets. This will help to catch material projected from the cutting action of the machine.
- 215.** The type of tooling in use and the height at which it is set will determine the size of the hole in the table (i.e., the gap between spindle and table). Use table rings to close the gap to a minimum. This reduces the risk of the work piece dipping and catching the edge as it passes over the gap.
- 216.** A demountable power feed unit should be used wherever possible for straight work. This should be easily adjustable to suit different sizes of work piece and should not, in itself, create a trapping hazard. When used in conjunction with a side pressure pad, a power feed unit often represents the best method of guarding.
- 217.** Where a demountable power feed unit cannot be used, the cutting area should be enclosed by vertical and horizontal spring-loaded pressure pads. These pads will then form a tunnel enabling the work piece to be safely fed through with the use of a push stick. The top and side pressure pads should be made of hardwood (those supplied with some new machines may also be plastic or light alloy) and be the same width and depth as the workpiece. They must also be long enough to prevent operators' hands from reaching the cutters.
- 218.** Before machining starts, the gap between the outfeed and infeed fences must be closed by the attachment of a false fence, allowing only that part of the cutter which is cutting to be exposed. It also provides good workpiece support and prevents the workpiece from 'dipping in' between fences.

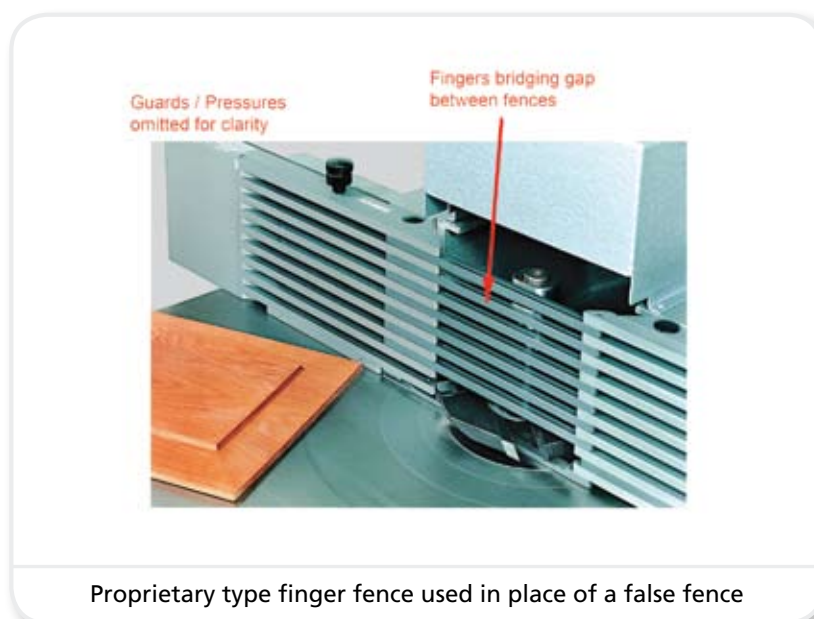

Machinery Safety - Specific

- 219.** Where stopped work is carried out, stops should be provided. Stops allow for greater control of the workpiece and, with the use of a jig, will help to prevent kick-back when dropping on. Typically, the jig containing the workpiece is placed against a backstop and then fed slowly onto the cutters to break in and then fed forwards against the false fence to the front stop where the workpiece and jig is removed from the cutters.



Use of jig for stopped work

- 220.** When setting up for shaped or curved work, the straight fence is removed and a ring fence or ring guide, together with an adjustable guard (traditionally a 'bonnet' guard), is fitted to enclose as much of the spindle and cutter block as possible. New style guards allow increased guarding and prevent contact with the cutter head.

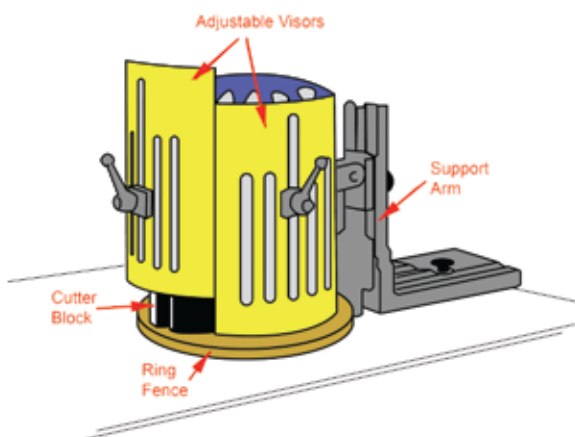

Traditional Bonnet Guard



Modern Style Guard

Machinery Safety - Specific

- 221.** Jigs should be constructed for curved work operations, to securely hold the component, with suitable hand holds to distance the operator from the cutter head. Jigs should be provided for one-off's and small batch runs as well as production quantities.

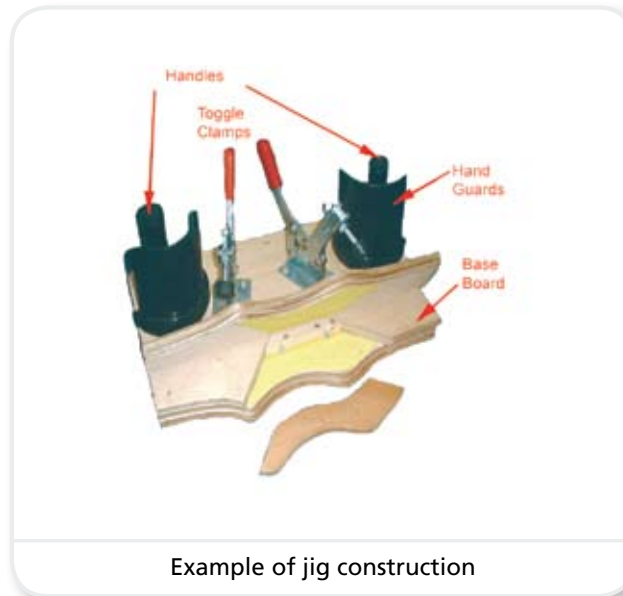

- 222.** Back cutting is a highly dangerous operation which should be discouraged even if a jig is used. This is because the operator cannot exert any force to resist the sudden forward movement of the workpiece if the cutter snatches. Wherever possible, feed the work-piece so that it cuts in the opposite direction of the spindle's rotations.
- 223.** Excessive depth of cuts should not be made as the material is likely to snatch and kickback towards the operator.
- 224.** Operators should check the material that is intended to be used to ensure that it is free from obvious defects.

Further reading

Health and Safety Executive Woodworking Information Sheet 18 'Safe use of vertical spindle moulding machines'

Machinery Safety - Specific

Narrow Band Saws

225. Narrow band saws are band saws fitted with blades of less than 50 mm in width. Although primarily used for making curved, irregular shaped, bevel tenon and wedge cuts in material, they can also be used for straight cuts with and without a fence.



Narrow Band Saw

- 226.** All parts of the saw blade must be enclosed by a substantial interlocked/ fixed guard, except for the working portion of the blade between the top wheel and the machine table.
- 227.** A fully adjustable guard must be provided to cover the exposed portion of the blade between the top wheel and the machine table. This guard should be attached to and moved with the top blade guide.
- 228.** The exposed part of the blade between the underside of the table and bottom pulley guard must be guarded at all angles of table tilt.
- 229.** Narrow band saws must be fitted with a braking device that brings the saw blade to rest within 10 seconds.

Common Problems

- 230.** The operator's hands come into contact with the moving blade whilst presenting material to the blade or removing it from the worktable.
- 231.** The operators may be injured when attempting to make adjustments to the machine whilst the band saw is in motion.

Machinery Safety - Specific

Common Solutions

- 232.** The pulleys and the blade, except the part which runs downwards between the top pulley and the machine table, should be enclosed by substantial interlocked fixed guards.
- 233.** An adjustable guard should be provided to cover that portion of the blade between the table and the top pulley enclosure. This guard should be attached to and moved with the top blade guide. It should be capable of being easily adjusted to suit the height of the work piece and firmly secured in position.
- 234.** The saw guides and attached adjustable guard should be adjusted as close to the work piece as possible before machining, and kept in place during machining.
- 235.** The part of the blade between the underside of the table and the lower guide, should be guarded at all angles of table tilt.
- 236.** The blade type and width should be suitable for the material being cut, with the blade teeth sharp and properly set, the blade correctly tensioned and tracked. The thickness of blade should be suitable for the pulley wheel diameter.
- 237.** Special jigs or work holders should be provided and used when cutting small pieces of material.
- 238.** Where fitted, a demountable power feed should be used wherever possible for straight work.
- 239.** Where practicable, the workpiece should be supported by a fence when straight cutting is carried out. For shallow work, use a low position fence to allow the blade guides and guard to be adjusted down to the work piece and also to permit safe removal of material from the blade using a push stick.
- 240.** Where it is not practicable to use a fence, the operator's hands should be kept in a safe position as far away from the blade as possible. When hands are unavoidably near to the blade they should be placed on either side of the blade, not in line with it.
- 241.** A push stick or guide block should be provided and used where possible to reduce the need for the operator's hands to be in close proximity to the blade.
- 242.** The table should support the whole workpiece. When a workpiece overhangs the table it should have adequate support using extension tables or roller trestles at both infeed and outfeed. Tipping of the workpiece is a common cause of accidents.
- 243.** Waste should be removed to ensure that the worktable is kept clear of obstructions.

Further reading

Health and Safety Executive Woodworking Information Sheet 31 'Safety in the use of narrow band sawing machines'

Machinery Safety - Specific

Single-End Tenoning Machines

- 244.** Tenoning machines use cutter heads and/or saw blades to form projections (tenons) and scribes on work pieces. The operator clamps the work piece to the machine table and then pushes the table towards the cutting areas of the machine.

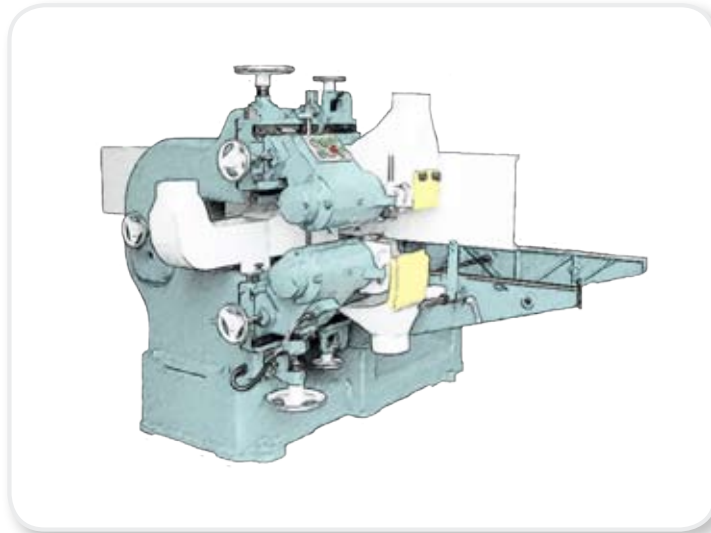
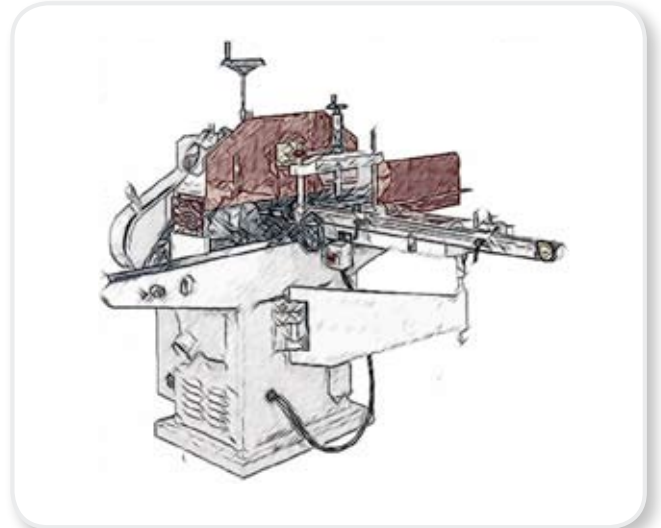
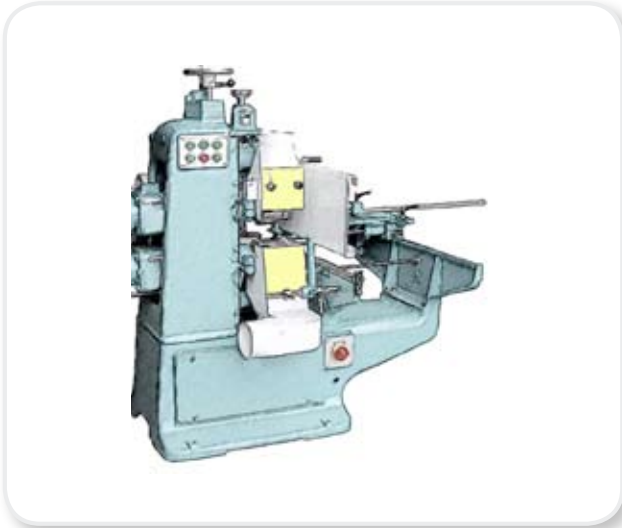

Examples of Single-End Tenoning Machines

- 245.** Every tenoning, scribing head and saw of a single-end tenoning machine should be enclosed by a substantial guard to the greatest extent that is possible. The guarding should be a combination of fixed guards and adjustable guards.
- 246.** Single head tenoning machines must be fitted with a braking device that brings the cutting head/s and saw blade/s to rest within 10 seconds.

Machinery Safety - Specific

Common Problems

- 247 The operator's hands may come into contact with the cutters during setting, adjustment, cleaning or clearing blockages whilst the machine is in operation.
- 248. The workpiece may be snatched by the cutters or saw blade and be kicked back towards the operator.
- 249. Wood splinters and chips created as a result of the cutting operation may be ejected from the machine.

Common Solutions

- 250. Access by persons other than operators should be restricted when the machine is in use. Restricted access can be achieved by careful positioning of the machine, i.e. locating it in an area where access to the sides and rear of the machine is prevented by walls, other fixed structures and machines. Where this is not possible, enclosures or suitable barriers should be erected. Care should be taken to ensure that trapping risks are not created between such barriers or enclosures and the moving table or work piece; this is particularly important on machines with powered tables.
- 251. The tenoning and scribing head(s) should be enclosed to the greatest extent practicable using a combination of fixed and adjustable guards. The local exhaust ventilation guards should form part of the fixed guarding arrangements so that they can be positioned as close as possible to the cutting operation. Adjustable guards should be used to keep the openings, through which the work piece has to pass, as small as possible.
- 252. Saws should be similarly enclosed. Where possible, spring-loaded or gravity fall guards which enclose the saw blade, opening only when the workpiece is being cut or withdrawn, should be fitted.
- 253. Where practicable, vertical plates should be fitted to the machining side of the sliding table, situated in front of and behind the workpiece. These plates prevent the operator's hands or arms from coming into contact with the cutters as the workpiece is taken through the machine.

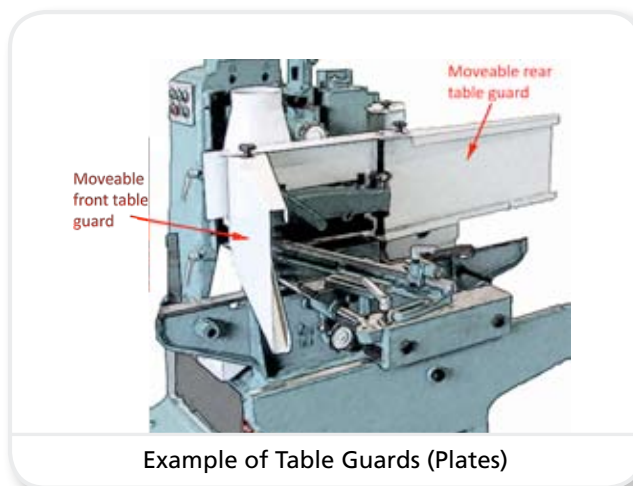

Example of Table Guards (Plates)

Machinery Safety - Specific

- 254.** The fence, break-out strip and/or guide fitted to the sliding table, should be properly secured and well maintained. Where there is a possibility of contact with the tool, the fence, break-out strip and/or guide should be made of material that will not damage the tool or otherwise cause additional danger.
- 255.** Particular attention should be paid to the maximum speed, dimensions and weight of the tool and/or tool sets as specified by the tool or machine manufacturers. All saws and cutters should be kept sharp and examined periodically for damage and defects.
- 256.** Only limited cutter projection tooling should be fitted to a scribing head. (Refer to the guidance on limited cutter projection tooling, set out in the section on vertical spindle moulding machines).
- 257.** Operators should ensure the workpiece is properly clamped. On most machines this is achieved by vertical or horizontal (side) clamps.
- 258.** There is a risk of the operator being trapped between the clamping device and the workpiece. This risk can be reduced by:
- Using two-stage clamping;
 - Reducing the gap between the clamp and the workpiece to less than 6 mm;
 - Guarding the clamping area.
- 259.** Where more than one workpiece is to be machined at a time, additional clamps should be provided and used, or other clamping arrangements made to ensure that all work pieces are held securely during the machining process.
- 260.** Where necessary, workpiece supports should be provided and used and care taken to maintain a common batch size.
- 261.** The area around the machine should be kept free of loose chippings etc, and exhaust ventilation should be provided for the safe removal of offcuts and wood dust. Because of the nature of the chippings that are produced by the tenoning heads, the ducts of the exhaust ventilation system are prone to blocking, especially where there are sharp bends. Where possible, the dust extraction system should include a flexible hose to facilitate cleaning the machine.

Further reading

Health and Safety Executive Woodworking Information Sheet 39 'Safe use of single-end tenoning machines'

Health – Wood Dust

- 262.** High dust levels can be created as a result of machining operations, in particular sawing, routing, turning and sanding. High dust levels may also be created by the use of compressed airlines to blow off dust from machines and other inappropriate methods of cleaning.
- 263.** Exposure to wood dust should be prevented, or where this is not reasonably practicable, adequately controlled.

Common Problems

- 264.** Exposure to wood dust has been associated with the following health problems:
- Skin disorders;
 - Obstruction in the nose;
 - A type of asthma;
 - A rare type of nasal cancer – caused by hardwood dust.
- 265.** A lack of cleaning or use of inappropriate cleaning methods can also result in a wood dust building up on the floor which can cause tripping or slipping hazards.
- 266.** The ability for the operator to have a clear view of the machining operation can be impaired by excessive dust and chips generated by the work.

Common Solutions

- 267.** Both hardwood and softwood dusts have a Workplace Exposure Limit (WEL) of 5mg/m³ which should not be exceeded. WELs are limits on concentrations of dust in the air, averaged over 8 hours. But, because wood dust is an asthmagen, exposure must be reduced as low as is reasonably practicable.
- Use a process or method of work that reduces the generation of dust to a minimum.
- 268.** Dust extraction, also known as local exhaust ventilation or LEV, should be provided to woodworking machines.
- 269.** Ensure that the dust extraction and collection system is maintained and examined at least once a year, to make sure it continues to work efficiently.
- 270.** For particularly dusty tasks such as sanding, respiratory protective equipment (RPE) as well as LEV should be provided. Other suitable personal protective equipment (PPE), such as eye protection, overalls and gloves, should be provided where necessary. RPE and PPE should be kept well maintained and clean.

Health – Wood Dust

- 271.** The use of airlines or dry sweeping to clear dust away should be avoided. Either an industrial free standing vacuum cleaner, fitted with HEPA filters, or preferably a vacuum attachment to the fixed dust extraction systems, should be used to clear up wood dust.
- 272.** Guidance on health checks and health surveillance is contained in the section on medical standards.

Further reading

Health and Safety Executive Woodworking Information Sheet 1 'Wood dust: hazards and precautions'

Health and Safety Executive Woodworking Information Sheet 6 'COSHH and the woodworking industries'

Health and Safety Executive Woodworking Information Sheet 14 'Selection of respiratory protective equipment for use with wood dust'

Health and Safety Executive Woodworking Information Sheet 30 'Toxic woods'

Health and Safety Executive Woodwork Control Guidance Sheet WD01 'Bandsaws'

Health and Safety Executive Woodwork Control Guidance Sheet WD02 'Circular bench saws'

Health and Safety Executive Woodwork Control Guidance Sheet WD03 'Cross-cut saws'

Health and Safety Executive Woodwork Control Guidance Sheet WD04 'Vertical spindle moulders'

Health and Safety Executive Woodwork Control Guidance Sheet WD06 'Sanding machines'

Health and Safety Executive Woodwork Control Guidance Sheet WD09 'Stand-alone dust collectors (occasional use)'

- 273.** The operation of woodworking machines gives rise to high noise levels which can result in operators' hearing being affected.
- 274.** Exposure to noise should be prevented, or where this is not reasonably practicable, adequately controlled by the use of hearing protection.
- 275.** A noise assessment should be carried out by a competent person where woodworking machinery is likely to exceed noise levels which may give rise to an operator suffering damage to their hearing.

Common Problems

- 276.** Operators who are exposed to high noise levels, even for a short time, may experience temporary hearing loss. If they continue to be exposed, serious permanent hearing loss can occur but sufferers often do not realise their hearing is being damaged. Exposure to noise can also cause a permanent ringing or whooshing sound in the ears which can be very distressing.
- 277.** If people have difficulty speaking to each other over approximately 2 metres then a personal noise exposure assessment is required. The assessment should be made by a competent person, someone who understands the legal requirements and their application to noise at work. The assessment should determine the action that is required to be taken at certain action values. These relate to:
- Lower action values: daily exposure of 80 dB, and peak sound pressure of 135 dB;
- Upper action values: daily exposure of 85 dB, and peak sound level of 137 dB.
- 278.** Weekly exposure levels can also be used to calculate personal noise exposures where the work carried out results in operators being exposed to varying day to day levels of noise exposure.
- 279.** There are also levels of noise exposure which must not be exceeded. These are a daily personal noise exposure of 87dB and a peak sound pressure of 140 dB. It is unlikely that the operation of woodworking machinery would exceed the peak sound pressure levels.
- 280.** The exposure limits, but not the action values, allow the effect of hearing protection to be taken into account.

Common Solutions

- 281.** Noise levels can be reduced through the use of some or all of three basic approaches to controlling noise: controlling noise at source, path controls (preventing noise reaching the operator) and hearing protection.

Health - Noise

- 282.** The control of noise at source, which typically consists of engineering controls, provides the most effective means of protection, since the controls actually reduce the amount of noise generated in the workplace. For this reason, it is best to attempt this option first, before moving on to path controls and, finally, to hearing protection devices.
- 283.** Controlling noise at source is commenced by carrying out a detailed analysis of each piece of noise-generating equipment. An attempt should be made to identify all noise sources within a given piece of equipment, as well as the ways in which the sound is transmitted (and often amplified via resonance or vibration) to the surrounding room. Then every effort should be made to both quiet the sources and dampen the resonant path-ways of transmission. Noise sources generally include motors, gears, belts and pulleys, points of operation where blades touch wood, and any other moving parts.
- 284.** Effective path controls involve isolating, blocking, diverting, absorbing, or otherwise reducing noise intensity before it reaches an operator's ears. Examples of path controls include moving or locating noisy machinery away from other operators, i.e. locating a saw mill in a separate building, and fitting sound enclosures to noisy machines.
- 285.** Hearing protection is considered to be the final line of defence for operators. Given the nature of woodworking operations it is likely that hearing protection will be required to be provided and worn by operators. Hearing protection must be selected to protect against the levels of noise in the workplace, be comfortable and be suitable for wearing with other PPE.

Further reading

Health and Safety Executive Woodworking Information Sheet 13 'Noise at woodworking machines'

Further Information

Further information on the application of this ACoP, or advice on the guidance set out in this publication, may be obtained by contacting the States of Jersey Health and Safety at Work Inspectorate, Social Security Department, PO Box 55, Philip Le Feuvre House, La Motte Street, St Helier, Jersey JE4 8PE. Telephone: 01534 447300 Fax: 01534 873791 Email: hsi@gov.je

The ACoP may be viewed at www.gov.je/hsi

Further copies of this publication can be obtained from the Health and Safety at Work Inspectorate or downloaded from the website.

Health and Safety Executive publications referred to in this document can be downloaded from the Health and Safety Executive website www.hse.gov.uk



Health and Safety at Work Inspectorate,
Social Security Department, P.O. Box 55, Philip Le Feuvre House, La Motte Street, St.Helier, Jersey JE4 8PE
Tel: 01534 447300 Fax: 01534 873791 E-mail: hsi@gov.je Website: www.gov.je/hsi