



*States of Jersey
Planning and Environment Committee*

The Building Bye-Laws (Jersey) 1997. Code of Practice

TECHNICAL GUIDANCE DOCUMENT

Part 1 Structure

Contents

	PAGE		PAGE
USE OF GUIDANCE	3	Section 2: Re-covering of roofs	29
STRUCTURE THE REQUIREMENTS	4	Section 3: Codes, Standards and other references for building types	
GUIDANCE		Loading	30
Performance	5	Structural work of timber	30
Introduction	5	Structural work of masonry	30
Section 1: Sizes of structural elements for certain residential buildings and other small buildings of traditional construction		Structural work of reinforced, pre-stressed or plain concrete	30
General	6	Structural work of steel	30
Definitions	6	Structural work of aluminium	30
Section 1A: Basic requirements for stability	7	Foundations	30
Section 1B: Sizes of timber floor, ceiling and roof members in single family houses		Existing buildings	30
Application	8	DISPROPORTIONATE COLLAPSE GUIDANCE	
The use of this section	8	Performance	31
Spans, sizes and spacings for timber members	8	Introduction	31
Section 1C: Thickness of walls in certain small buildings		Section 4: Reducing the sensitivity of the building to disproportionate collapse in the event of an accident	32
Application	11	Alternative Approach	33
Wall types	11	Appendix A	
The use of this section	11	Tables of sizes of timber floor, ceiling and roof members in single family houses	34
Thickness of walls	11	Standards referred to	50
Conditions relating to the building of which the walls form part	15		
Conditions relating to the wall	16		
Construction materials and workmanship	16		
Loading on walls	19		
End restraint	20		
Openings, recesses, overhangs and chases	22		
Lateral support by roofs and floors	23		
Interruption of lateral support	25		
External walls of small single storey non-residential buildings and annexes	25		
Section 1D: Proportions for masonry chimneys above the roof surface			
Height to width relationship	26		
Section 1E: Strip foundations of plain concrete			
Conditions relating to the sub-soil	27		
Design provisions	27		
Minimum width of strip foundations	27		

	PAGE		PAGE
DIAGRAMS		TABLES	
1. Key to tables A1-A15 in appendix A relating to timber members	9	1. Common timber species/grade combinations	8
2. Determination of wall thickness	12	2. Summary of tables A1-A15 in Appendix A relating to timber members	10
3. Exclusion of wall containing a bay	13	3. Strutting to joists	10
4. Parapet walls: height	14	4. Wall types considered in this section	11
5. Size and proportion of residential buildings of not more than 3 storeys	15	5. Minimum thickness of certain external walls, compartment walls, and separating walls	12
6. Size of single storey non-residential buildings	15	6. Maximum spacing of cavity wall ties	13
7. Size of annexes	15	7. Imposed loads	16
8. Maximum floor area enclosed by structural walls	16	8. Value factor 'x'	22
9. Measuring storey and wall heights	17	9. Lateral support for walls	23
10. Compressive strength of brick and block units	18	10. Minimum width of strip foundations	28
11. Maximum span of floors	19	Tables A1–A15 relating to timber members are in Appendix A	35–49
12. Differences in ground level	19		
13. Openings in a buttressing wall	20		
14. Buttressing	21		
15. Sizes of openings and recesses	22		
16. Lateral support by floors	23		
17. Lateral support at roof level	24		
18. Pier size and spacing	25		
19. Proportions for masonry chimneys	26		
20. Elevation of stepped foundation	27		
21. Piers and chimneys	27		
22. Foundation dimensions	28		
23. Area at risk of collapse in the event of an accident	32		

Use of Guidance

THE TECHNICAL GUIDANCE DOCUMENTS

The Building Bye-Laws (Jersey) 1997, which come into operation on the twentieth day of February 1997, replace the Building Bye-Laws (Jersey) 1960 and consolidate all subsequent revisions to those Bye-Laws. This document is one of a series that has been approved by the Committee as practical guidance on meeting the requirements of the second schedule and Bye-Law 7 of the Building Bye-Laws (Jersey) 1997.

At the back of this document is a list of those documents currently published which have been approved for the purpose of the Building Bye-Laws.

The detailed provisions contained in the Technical Guidance Documents are intended to provide guidance for some of the more common building situations. In other circumstances, alternative ways of demonstrating compliance with the requirements may be appropriate.

Evidence supporting compliance

There is no obligation to adopt any particular solution contained in a Technical Guidance Document if you prefer to meet the relevant requirement in some other way. However, should a contravention of a requirement be alleged then, if you have followed the guidance in the relevant Technical Guidance Documents, that will be evidence tending to show that you have complied with the Bye-Laws. If you have not followed the guidance then that will be evidence tending to show that you have not complied. It will then be for you to demonstrate by other means that you have satisfied the requirement.

Other requirements

The guidance contained in a Technical Guidance Document relates only to the particular requirements of the Bye-Laws which that document addresses. The building work will also have to comply with the requirements of any other relevant paragraphs in the second schedule to the Bye-Laws. There are Technical Guidance Documents which give guidance on each of the other requirements in the second schedule and on Bye-Law 7.

LIMITATION ON REQUIREMENTS

In accordance with Bye-Law 8, the requirements in Parts 1, 2, 3, 4, 5, 6, 7, 9 and 10 of the second schedule to the Building Bye-Laws do not require anything to be done except for the purpose of securing reasonable standards of health and safety for persons in or about the building.

MATERIALS AND WORKMANSHIP

Any building work which is subject to requirements imposed by the second schedule to the Building Bye-Laws should, in accordance with Bye-Law 7, be carried out with proper materials and in a workmanlike manner.

You may show that you have complied with Bye-Law 7 in a number of ways, for example, by the appropriate use of a product bearing an EC mark in accordance with the Construction Products Directive (89/106/EEC), or by following an appropriate technical specification (as defined in that Directive), a British Standard, a British Board of Agrément Certificate, or an alternative national technical specification of any member state of the European Community which, in use, is equivalent. You will find further guidance in the Technical Guidance Documents supporting Bye-Law 7 on materials and workmanship.

Technical specifications

Building Bye-Laws are made for specific purposes; health and safety, energy conservation and the welfare and convenience of disabled people. Standards and technical approvals are relevant guidance to the extent that they relate to these considerations. However, they may also address other aspects of performance such as serviceability or aspects which although they relate to health and safety are not covered by the Bye-Laws.

When a Technical Guidance Document makes reference to a named standard, the relevant version of the standard is the one listed at the end of the publication. However, if this version of the standard has been revised or updated by the issuing standards body, the new version may be used as a source of guidance provided it continues to address the relevant requirements of the Bye-Laws.

The Requirements

This technical Guidance Document which takes effect on 20 February 1997, deals with the following requirements from part 1 of the second schedule to the Building Bye-Laws (Jersey) 1997.

<i>Requirement</i>	<i>Limits on application</i>
<p>Loading</p> <p>(1) (1) Every building shall be constructed so that the combined dead, imposed and wind loads to which the building may be subjected are sustained and transmitted to the ground—</p> <p>(a) safety; and</p> <p>(b) without causing such deflection or deformation of any part of the building, or such movement of the ground as will impair the stability of the building or any part of another building.</p> <p>(2) In assessing whether a building complies with sub-paragraph (1) regard shall be had to the imposed and wind loads which it is likely to be subjected in the ordinary course of its use for the purpose for which it is intended.</p>	<p>Requirement 3 applies only to a building having five or more storeys. In counting the number of storeys, each basement level shall be counted as one storey, and where the roof pitch does not exceed 70 degrees to the horizontal and there is a single storey within that roof space, this storey shall not be counted.</p>
<p>Ground Movement</p> <p>(2) Every building shall be constructed so that, in so far as the risk can reasonably be foreseen, movement of the subsoil caused by landslip, swelling or freezing will not impair the stability of any part of the building.</p>	
<p>Disproportionate Collapse</p> <p>(3) Every building shall be constructed so that in the event of an accident the building will not suffer collapse to an extent disproportionate to the cause.</p>	

PERFORMANCE

0.1 In the view of the committee requirements (1) and (2) of Part 1 will be met by adopting the guidance in sections 1 and 2 or by following the recommendations given in the documents listed in section 3.

Introduction

Sections 1-3 give guidance on the following:

- a. **Section 1** gives sizes of structural elements for certain residential buildings and other small buildings of traditional construction.
- b. **Section 2** gives guidance where roofs are to be re-covered as a material alteration as defined in the Bye-Laws.
- c. **Section 3** is relevant to all building types and lists Codes, Standards and other references for structural design and construction but, where they do not give precise guidance, consideration should be given to paragraph 0.2.

0.2 The safety of a structure depends on the successful combination of design and construction, particularly:

- a. loading, where dead and imposed loads should be in accordance with BS 6399: Parts 1 and 3, and wind loads in accordance with CP3 Chapter V Part 2.
- b. Properties of materials
- c. Design analysis
- d. Details of construction
- e. Safety factors
- f. Workmanship

The numeric values of safety factors, whether expressed explicitly or implicitly in design equations, or design values, should be derived from considerations of the above aspects of design and construction as a whole. A change in any one of these aspects may disturb the safety of the structure.

Loads used in calculations should allow for possible dynamic, concentrated and peak load effects that may occur.

Section 1

SIZES OF STRUCTURAL ELEMENTS FOR CERTAIN RESIDENTIAL BUILDINGS OF TRADITIONAL CONSTRUCTION

General

1.1 This Section is presented as follows:

Section 1A

Basic requirements for stability.

Section 1B

Sizes of certain timber floor, ceiling and roof members in single family houses of not more than 3 storeys.

Section 1C

Thickness of masonry walls in certain residential buildings of not more than 3 storeys, small single storey non residential buildings and annexes.

Section 1D

Proportions for masonry chimneys.

Section 1E

Width of strip foundations of plain concrete.

1.2 Section 1A gives general rules which must be observed in following Sections 1B and 1C. Sections 1B to 1E may be used independently of each other.

Throughout this section the diagrams are only illustrative and do not show all the details of construction.

Definitions

1.3 The following meanings apply to terms throughout this Section:

Buttressing wall A wall designed and constructed to afford lateral support to another wall perpendicular to it, support being provided from the base to the top of the wall.

Cavity width The horizontal distance between the two leaves of a cavity wall.

Compartment wall A wall constructed as a compartment wall to meet the requirements of Part 2 of the second schedule to the Bye-Laws.

Dead load The load due to the weight of all walls, permanent partitions, floors, roofs and finishing including services, and all other permanent construction.

Imposed load The load assumed to be produced by the intended occupancy or use, including the weight of moveable partitions, distributed, concentrated, impact, inertia and snow loads, but excluding wind loads.

Pier A member which forms an integral part of a wall, in the form of a thickened section at intervals along the wall, so as to afford lateral support to the wall to which it is bonded or securely tied.

Spacing The distance between the longitudinal centres of any two adjacent timber members of the same type, measured in the plane of floor, ceiling or roof structure.

Span The distance measured along the centre line of a member between the centres of any two adjacent bearings or supports.

Note: The spans given in Section 1B and Appendix A for the floor joists, rafters, purlins, ceiling joists, binders and roof joists are **clear spans** i.e. spans between the faces of the supports.

Supported wall A wall to which lateral support is afforded by a combination of buttressing walls, piers or chimneys acting in conjunction with floor(s) or roof.

Wind load The load due to the effect of wind pressure or suction.

Section 1A

BASIC REQUIREMENTS FOR STABILITY

1A1 This Section must be used in conjunction with sections 1B and 1C.

1A2 Trussed rafter roofs should be braced to the recommendations of BS 5268: Part 3: 1985.

Where a traditionally framed roof (i.e. using rafters, purlins and ceiling joists) does not have sufficient built in resistance to instability, for instance from hipped returns, rigid sarking or the like, then bracing equivalent to that recommended in BS 5268: Part 3: 1985 should be considered.

1A3 If the roof structure is braced as described in paragraph 1A2 above and is adequately anchored to the structure beneath, and the walls are designed and restrained in accordance with the requirements of Section 1C, no special provision should be needed to take account of loads due to the effect of wind pressure or suction.

Section 1B

SIZES OF CERTAIN TIMBER FLOOR CEILING AND ROOF MEMBERS IN SINGLE FAMILY HOUSES

Application

1B1 This Section only applies to single family houses of not more than 3 storeys.

The use of this Section

1B2 This Section must be used in conjunction with Section 1A.

Spans, sizes and spacings for timber members

1B3 The guidance given in this Section assumes that:

- a. the dead and imposed loads to be sustained by the floor, ceiling or roof of which the member forms part do not exceed the values given in the notes to the appropriate diagrams and the tables, and
- b. the species and grade of timber for the strength class to which the Table relates is either—
 - i. as given in Table for more common species, or
 - ii. as given in the more comprehensive Tables of BS 5268: Part 2: 1991, and

Table 1 Common species/grade combinations which satisfy the requirements for the strength classes to which Tables A1-A15 Appendix A relate

Species	Grading		Grades to satisfy strength class				
	Origin	Rules	SC3			SC4	
Redwood or whitewood	Imported	BS 4978	GS	MGS	M50	SS	MSS
Douglas Fir	UK	BS 4978	M50	SS	MSS	-	-
Larch UK	BS 4978	GS	MGS	M50	SS	MSS	
Scotch Pine	UK BS 4978	GS	MGS	M50	SS	MSS	
Corsican Pine	UK	BS 4978		M50		SS	MSS
European Spruce	UK	BS 4978		M75			
Sitka Spruce	UK	BS 4978		M75			
Douglas Fir-Larch Hem-Fir Spruce-Pine-Fir	CANADA	BS 4978	GS	MGS	M50	SS	MSS
Douglas Fir-Larch Hem-Fir Spruce-Pine-Fir	CANADA	NLGA	Joist & Plank No. 1 & No. 2 Struct. L.F. No. 1 & No. 2			Joist & Plank Struct. L.F.	Select Select
Douglas Fir-Larch Hem-Fir Spruce-Pine-Fir	CANADA	MSR	Machine Stress-Rated 1450f-1.3E			Machine Stress-Rated 1650f-1.5E	
Douglas Fir-Larch	USA	BS 4978	GS	MGS		SS	MSS
Hem-Fir	USA	BS 4978	GS	MGS	M50	SS	MSS
Western Whitewoods	USA	BS 4978	SS	MSS		-	-
Southern Pine	USA	BS 4978	GS	MGS		SS	MSS
Douglas Fir-Larch	USA	NGRDL	Joist & Plank No. 1 & No. 2 Struct. L.F. No. 1 & No. 2			Joist & Plank Struct. L.F.	Select Select
Hem-Fir	USA	NGRDL	Joist & Plank No. 1 & No. 2 Struct. L.F. No. 1 & No. 2			Joist & Plank Struct. L.F.	Select Select
Western Whitewoods	USA	NGRDL	Joist & Plank Struct. L.F.	Select Select		-	-
Southern Pine	USA	NGRDL	Joist & Plank	No. 3 Stud grade		Joist & Plank	Select
Douglas Fir-Larch Hem-Fir Southern Pine	USA	MSR	Machine Stress-Rated 1450f-1.3E			Machine Stress-Rated 1650f-1.5E	

Notes: the common species/grade combinations given in this table are for particular use with the other tables in Appendix A and for cross section sizes given in those tables.

Definitive and more comprehensive tables for assigning species/grade combinations to strength classes are given in BS 5268: Part 2: 1991. The grading rules for American and Canadian Lumber are those approved

by the American Lumber Standards (ALS) Board of Review and the Canadian Lumber Standards (SLS) Accreditation Board respectively (see BS 5268: Part 2: 1991).

NLGA denotes the National Lumber Grading Association
NGRDL denotes the National Grading Rules for Dimension Lumber
MSR denotes the North American Export Standard for Machine Stress-Rated Lumber.

c. floorboarding complying with BS 1297: 1987 is used.

1B4 The strength classes, species, grades and species combinations referred to in this Section are as defined in BS 5268: Part 2: 1991.

1B5 The cross sectional dimensions given in the Tables to this Section in Appendix A are applicable to either basic sawn or regularised sizes as defined in BS 4771: 1987. Reference should be made to the accompanying notes to the Tables to determine whether sawn or regularised sizes apply. The Tables do not apply where dimensions have been reduced by planing. For timber of North American origin the Tables apply only as indicated to surface sizes unless the timber has been resawn to BS 4471 requirements.

1B6 Notches and holes in simply supported floor and roof joists should be within the following limits.

a. **notches** should be no deeper than 0.125 times the depth of a joist and should not be cut closer to the support than 0.07 of the span, nor further away than 0.25 times the span, and

b. **holes** should be no greater diameter than 0.25 times the depth of the joist; should be drilled at the neutral axis; and should not be less than 3 diameters (centre to centre) apart; and should be located between 0.25 and 0.4 times the span from the support.

No notches or holes should be cut in roof rafters, other than at supports where the rafter may be birdsmouthed to a depth not exceeding 0.33 times the rafter depth.

1B7 Bearing areas and workmanship should comply with the relevant requirements of BS 5268: Part 2: 1991. Refer also to paragraphs 1C33 to 1C37.

1B8 Diagram 1 and Table 2 refer to Tables with accompanying diagrams and notes that give spans sizes and spacings for certain timber floor,

Diagram 1 Key to Tables A1–A15 in Appendix A relating to timber members

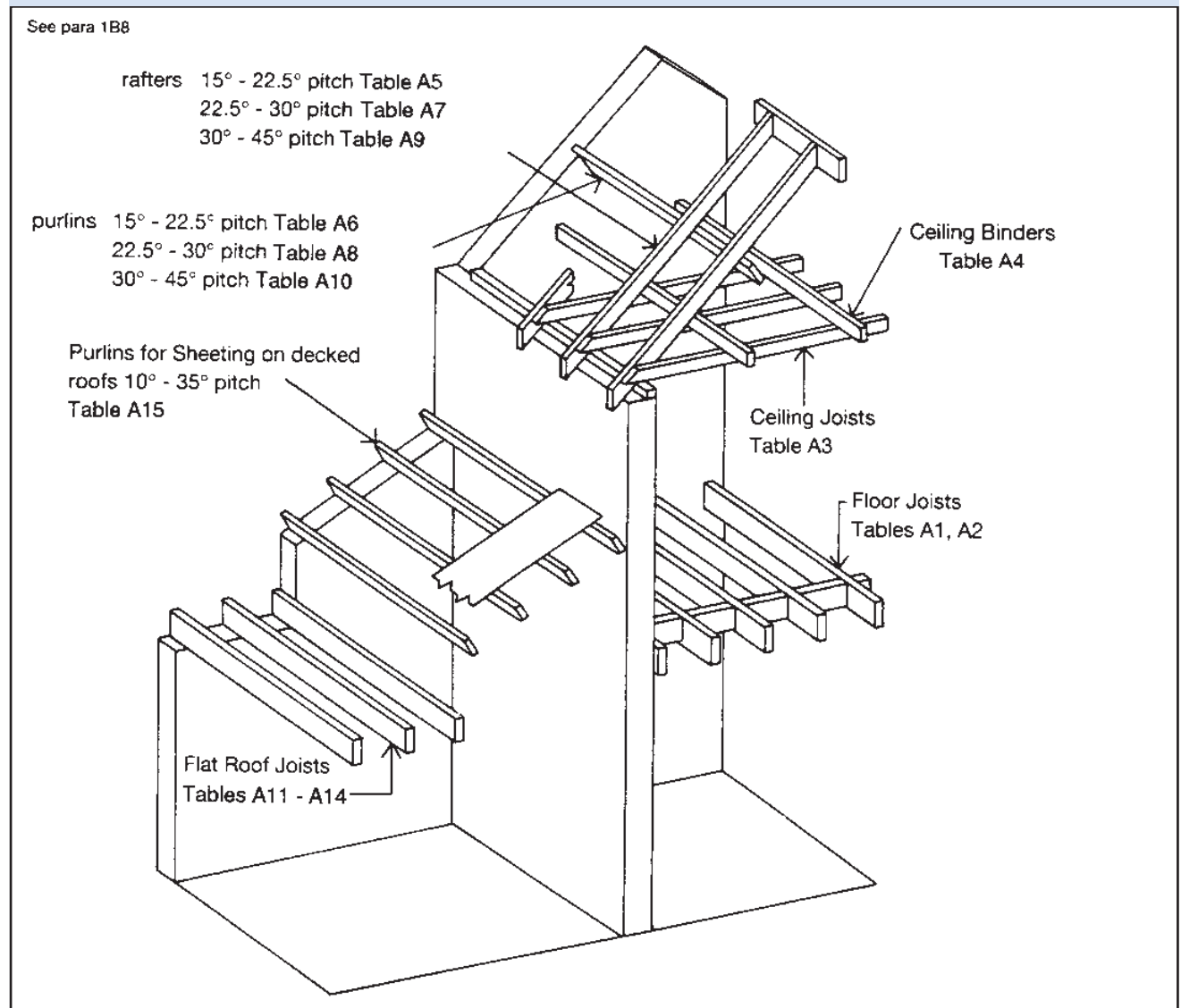

Table 2 Summary of Tables A1-A15 in Appendix A relating to timber members

Construction	Timber members	Imposed Loading KN/m ²	Table numbers Strength class	
			SC3	SC4
Floors	joists		A1	A2
Ceilings	joists		A3	A3
	binders		A4	A4
Pitched roofs greater than 15° but less than or equal to 22½°	rafters	0.75	A5	A5
	purlins	0.75	A6	A6
Pitched roofs greater than 22½° but less than or equal to 30°	rafters	0.75	A7	A7
	purlins	0.75	A8	A8
Pitched roofs greater than 30° but less than or equal to 45°	rafters	0.75	A9	A9
	purlins	0.75	A10	A10
Flat roofs access for maintenance only	joists	0.75	A11	A12
Flat roofs full access allowed	joists		A13	A14
Sheeted or decked roofs greater than 10° but less than or equal to 35°	purlins	0.75	A15	A15

Notes

1 The strength class given in this table assumes that the species and grades of timber to be used are those described in Table 1.

2 The diagrams are only illustrative and do not show all details of construction. Adequate connections between members should be provided as appropriate.

3 These tables do not apply to trussed rafter roofs.

ceiling and roof members in Appendix A. In Tables A1-A15 all spans except those for floorboards are measured as the clear dimension between supports and all spacings are the dimensions between longitudinal centres of members.

1B9 Floor joists spanning in excess of 2.5m should be strutted by one or more rows of solid or herringbone strutting in accordance with Table 3. Solid strutting should be at least 38mm timber thickness extending at least 0.75 times the depth of the joists. Herringbone strutting should be of at least 38mm x 38mm timber size but should not be used where the distance between joists is greater than 3 times the depth of the joists.

Table 3 Strutting to joists

Joist span m	No of rows of strutting
less than 2.5	none
2.5–4.5	1 at mid-span
more than 4.5	2 at one third span positions

SECTION 1C

THICKNESS OF WALLS IN CERTAIN SMALL BUILDINGS

Application

1C1 This Section applies to the following building types:

- a. residential buildings of not more than three storeys, and
- b. small single storey non-residential buildings, and
- c. small buildings forming annexes to residential buildings, (including garages and outbuildings).

Wall types

1C2 Only the types of wall given in Table 4, which must extend to the full storey height, and parapet walls are considered in this section.

The use of this Section

1C3 When using this Section it should be noted that:

- a. this section must be used in conjunction with Section 1A;
- b. if wall thickness is to be determined according to paragraphs 1C4 to 1C13, all appropriate design conditions given in this section must be satisfied;
- c. walls should comply with the relevant requirements of BS 5628: Part 3: 1985, except as regards the conditions given in paragraphs 1C14 to 1C38;
- d. in formulating the guidance of this section the worst combination of circumstances likely to arise was taken into account. If a requirement of this part is considered too onerous in a particular case it may be appropriate to consider a minor departure on the basis of judgement and experience, or to show adequacy by calculation in respect of the aspect of the wall which is subject to the departure rather than for the entire wall;

Table 4 Wall types considered in this Section

Residential buildings of up to three storeys

external walls
internal loadbearing walls
compartment walls

Small single storey non-residential buildings and annexes

external walls
internal loadbearing walls

e. the guidance given is based upon the compressive strengths of bricks and blocks of:

- i. bricks 5, 7 and 15 N/mm²,
- ii. blocks 2.8 and 7 N/mm²,

depending on circumstances (see Diagram 10).

BS 5628: Part 1: 19768 gives design strength for walls where the suitability for use of masonry units of other compressive strengths is being considered.

Thickness of walls

1C4 General wall thickness may be determined according to this Section provided:

- a. conditions relating to the building of which the wall forms a part (see paragraphs 1C14 to 1C16), and
 - b. conditions relating to the wall (see paragraphs 1C17 to 1C38)
- are met. (see Diagram 2).

Diagram 2 Determination of wall thickness

See para 1C4

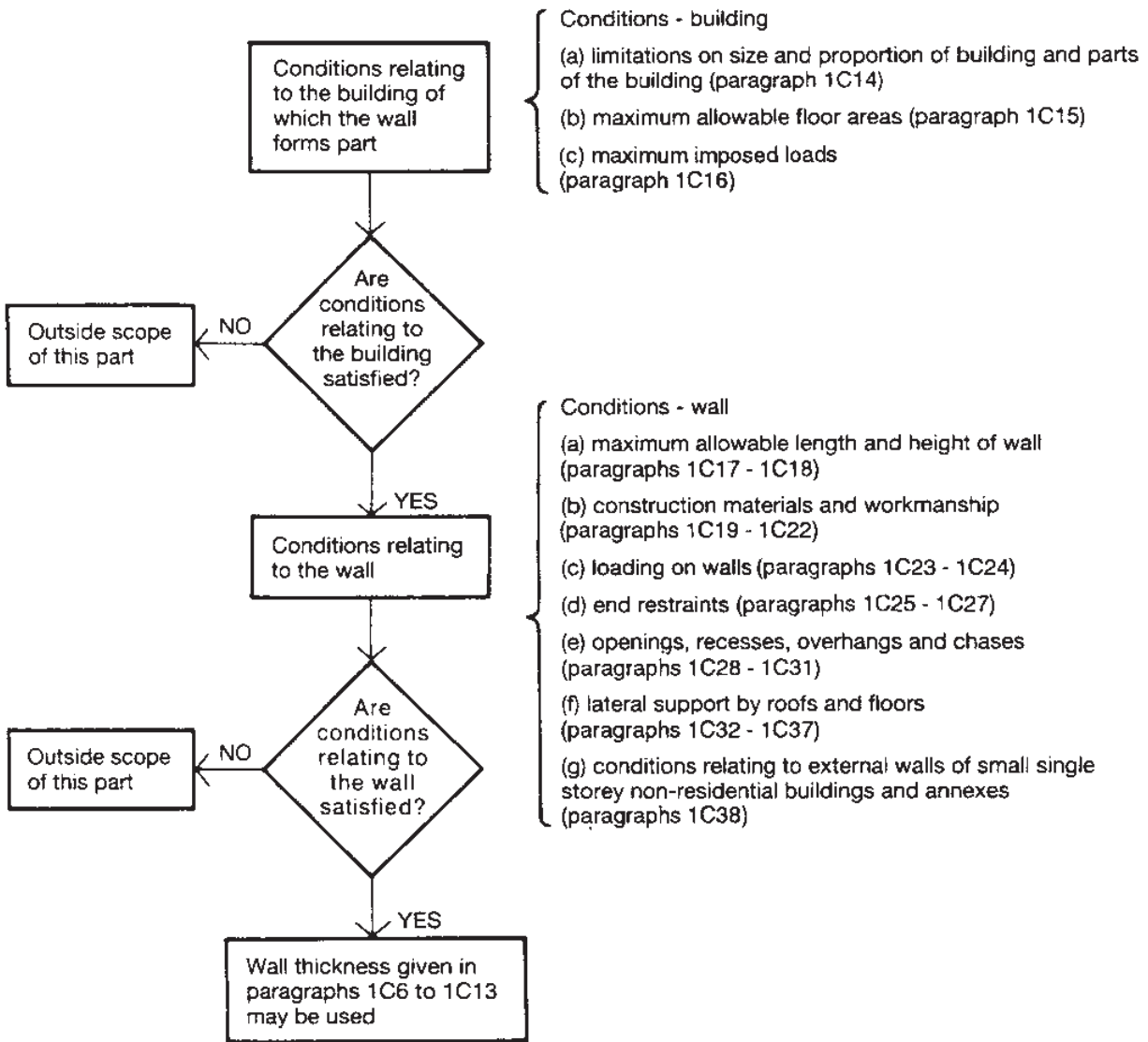
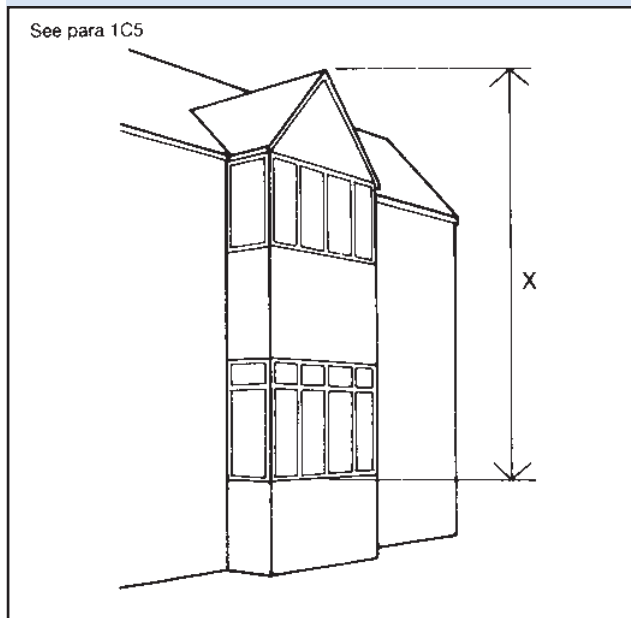

Table 5 Minimum thickness of certain external walls and compartment walls

Height of wall	Length of wall	Minimum thickness of wall
not exceeding 3.5m	not exceeding 12m	190mm for whole of its height
exceeding 3.5m but not exceeding 9m	not exceeding 9m	190mm for whole of its height
	exceeding 9m but not exceeding 12m	290mm from the base for the height of one storey and 190mm for the rest of its height
exceeding 9m but not exceeding 12m	not exceeding 12m	290mm from the base for the height of two storeys and 190mm for the rest of its height

1C5 Exceptions – Walls forming part of a bay window: This Section does not apply to any portion of an external wall which is constructed as a bay for, or as a gable over, a bay window above ground floor cill level. (indicated as X in Diagram 3).

Diagram 3 Exclusion of wall containing a bay



1C6 Solid external walls and compartment walls in coursed brickwork or blockwork: Solid walls constructed of coursed brickwork or blockwork should be at least as thick as 1/16 of the storey height. Further requirements are given in Table 5.

1C7 Solid external walls and compartment walls of uncoursed stone, flints etc.: The thickness of walls constructed in uncoursed stone, flints, clunches, of bricks or other burnt or vitrified material should not be less than 1.33 times the thickness determined by paragraph 1C6.

1C8 Cavity walls in coursed brickwork or blockwork: All cavity walls should have leaves at least 90mm thick and cavities at least 50mm wide. For maximum width of cavity and spacing of cavity wall ties refer to Table 2. For specification of wall ties refer to paragraph 1C19.

For external walls and compartment walls in cavity construction, the combined thickness of the two leaves plus 10mm should not be less than the thickness determined by paragraph 1C6 for a solid wall of the same height and length.

1C9 Walls providing vertical support to other walls: Irrespective of the materials used in the construction, a wall should not be less in thickness than any part of the wall to which it gives vertical support.

1C10 Internal loadbearing walls in brickwork or blockwork: (except compartment walls) should have a thickness not less than:

$$\frac{\text{specified thickness from Table 5}}{2} - 5\text{mm}$$

except for a wall in the lowest storey of a three storey building, carrying load from both upper storeys, which should have a thickness as determined by the above equation or 140mm whichever is the greatest.

Table 6 Maximum spacing of cavity wall ties

Width of cavity (mm)	Horizontal spacing (mm)	Vertical spacing (mm)	Other comment
50-75	900	450	See notes 1 and 2
76-100	750	450	See notes 1, 2 and 3

Notes

1 The horizontal and vertical spacing of wall ties may be varied if necessary to suit the construction provided the number of ties per unit is maintained.

2 Wall ties spaced not more than 300mm apart vertically should be provided within 225mm from the sides of all openings with unbonded jambs.

3 Vertical Twist Type ties, or ties of equivalent performance should be used in cavities wider than 75mm.

Diagram 4 Parapet walls: height

See para 1C11

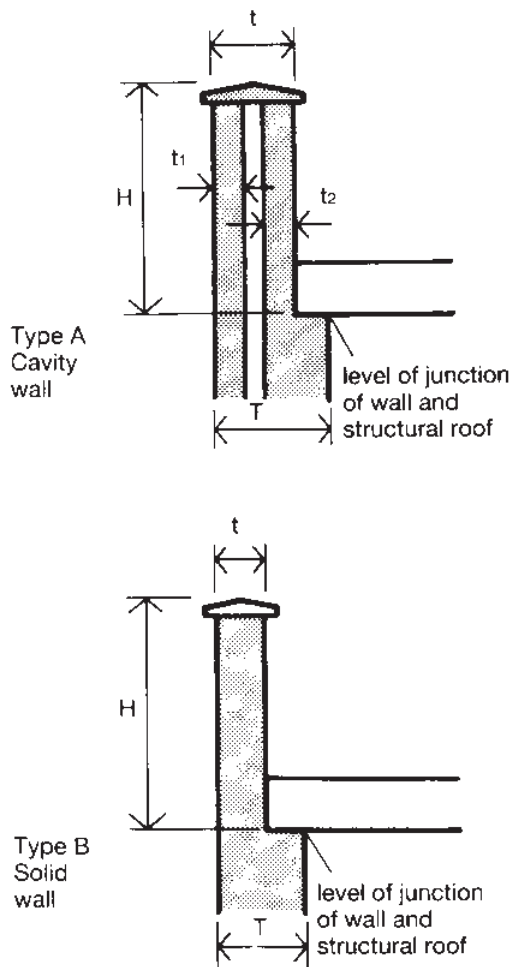

Wall type	Thickness (mm)	Parapet height H to be not more than (mm)
Type A Cavity wall	$t_1 + t_2$ equal or less than 200	600
	$t_1 + t_2$ greater than 200 equal to or less than 250	860
Type B Solid wall	$t = 150$	600
	$t = 190$	760
	$t = 215$	860

Note: t should be less than or equal to T

1C11 Parapet walls: the minimum thickness and maximum height of parapet walls should be as given in diagram 4.

1C12 Single leaves of certain external walls:

The single leaf of external walls of small single storey non-residential buildings and of annexes need be only 90mm thick, notwithstanding paragraph 1C38.

1C13 Modular bricks and blocks:

Where walls are constructed of bricks or blocks having modular dimensions derived from BS 6750: 1986, wall thicknesses prescribed in this section which derive from a dimension of brick or block may be reduced by an amount not exceeding the deviation from work size permitted by a British Standard relating to equivalent sized bricks or blocks made of the same material.

Conditions relating to the building of which the wall forms part

1C14 This Section applies only to buildings having proportions within the following parameters (see diagrams 5, 6 and 7).

a. residential buildings of not more than 3 storeys:

- i. the maximum height of the building measured from the lowest finished ground level adjoining the building to the highest point of any wall or roof should not be greater than 12m,

- ii. the height of the building H should not exceed twice the least width of the building W_1 ,
 - iii. the height of the wing H_2 should not exceed twice the least width of the wing W_2 where the projection P exceeds twice the width W_2 .
- b. **small single-storey non-residential buildings:** height H should not exceed 3m and W should not exceed 9m (see Diagram 6),
- c. **annexes:** height H should not exceed 3m, (see Diagram 7).

Diagram 5 Size and proportion of residential buildings of not more than 3 storeys

See para 1C14

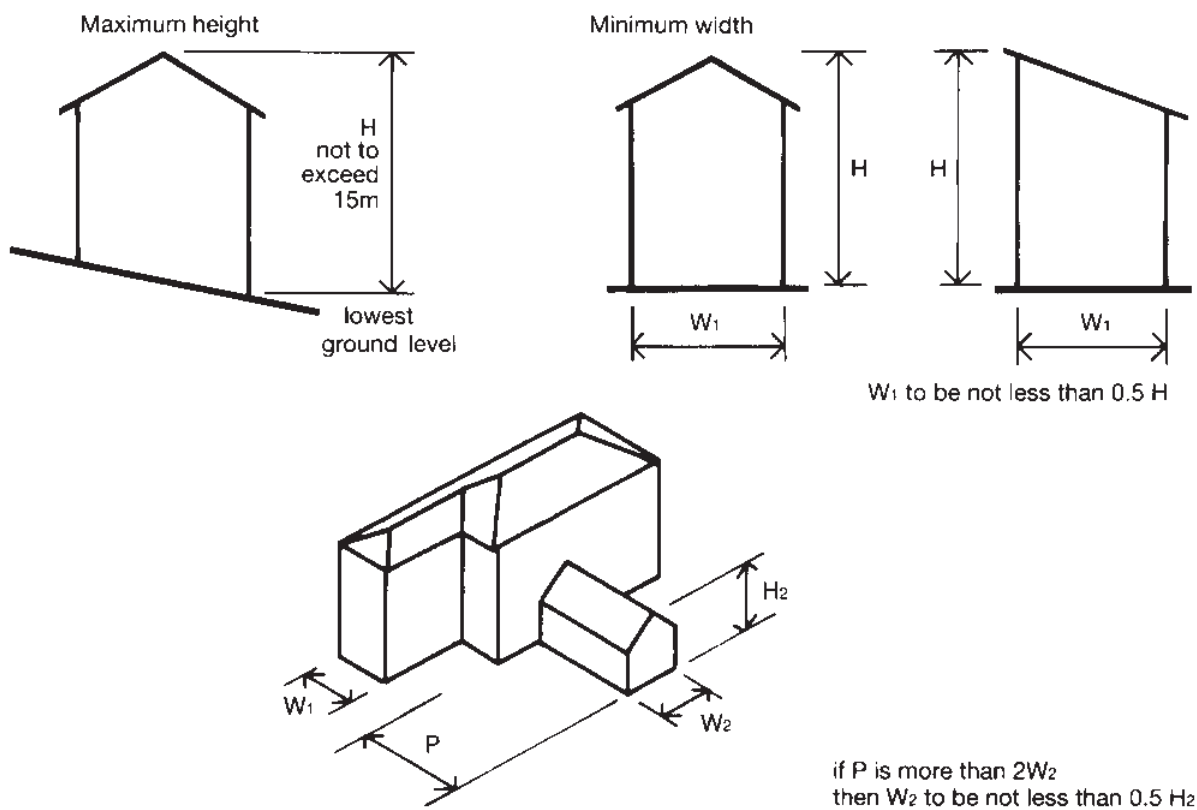

Diagram 6 Size of single storey non residential buildings

See para 1C14b

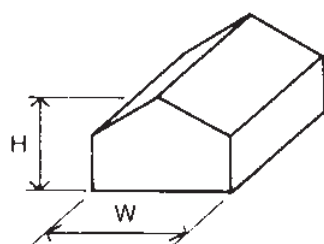
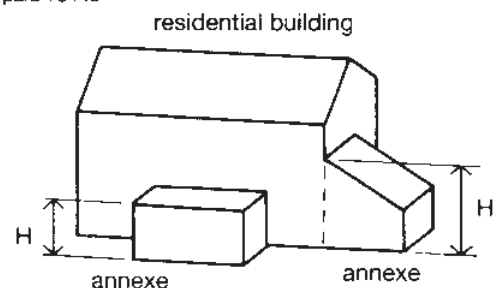

Diagram 7 Size of annexes

See para 1C14c



1C15 Maximum floor area: The guidance of this Section assumes that no floor enclosed by structural walls on all sides exceeds 70m²; and that no floor without a structural wall on one side exceeds 30m², (see Diagram 8).

Diagram 8 Maximum floor area enclosed by structural walls

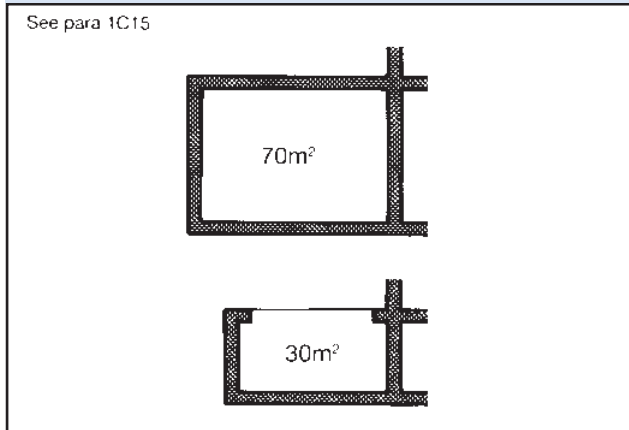

1C16 Imposed loads on roofs, floors and ceilings: The design considerations given in this Section are intended to be adequate for the imposed loads given in Table 7.

Table 7 Imposed loads

Element	Loading
roof	distributed load: 1.00 kN/m ² for spans not exceeding 12m 1.5kN/m ² for spans not exceeding 6m
floors	distributed load: 2.00kN/m ²
ceilings	distributed load: 0.25kN/m ² together with concentrated load: 0.9kN

Conditions relating to wall

1C17 Maximum allowable length and height of the wall: This Section does not deal with walls longer than 12m, measured from centre to centre of buttressing walls, piers or chimneys providing restraint, or with walls exceeding 12m in height. (See also Table 5).

1C18 Rules of measurement for heights of walls and storeys: The height of a wall or a storey should be measured in accordance with the rules in Diagram 9.

Construction materials and workmanship

1C19 Wall ties: Wall ties should comply with BS 1243: 1978 or be of other not less suitable type. In conditions of severe exposure austenitic stainless steel or suitable non-ferrous ties should be used, (for definition of severe exposure, refer to BS 5628: Part 3: 1985).

1C20 Brick and block construction: Walls should be properly bonded and solidly put together with mortar and constructed of:

- clay bricks or blocks conforming to BS 3921: 1874 or BS 6649: 1985, or
- calcium silicate bricks conforming to BS 187: 1978 or BS 6649: 1985, or
- concrete bricks or blocks conforming to BS 6073: Part 1: 1981, or
- square dressed natural stone conforming to the appropriate requirements described in BS 5390: 1976 (1984).

Diagram 9 Measuring storey and wall heights

See para 1C18

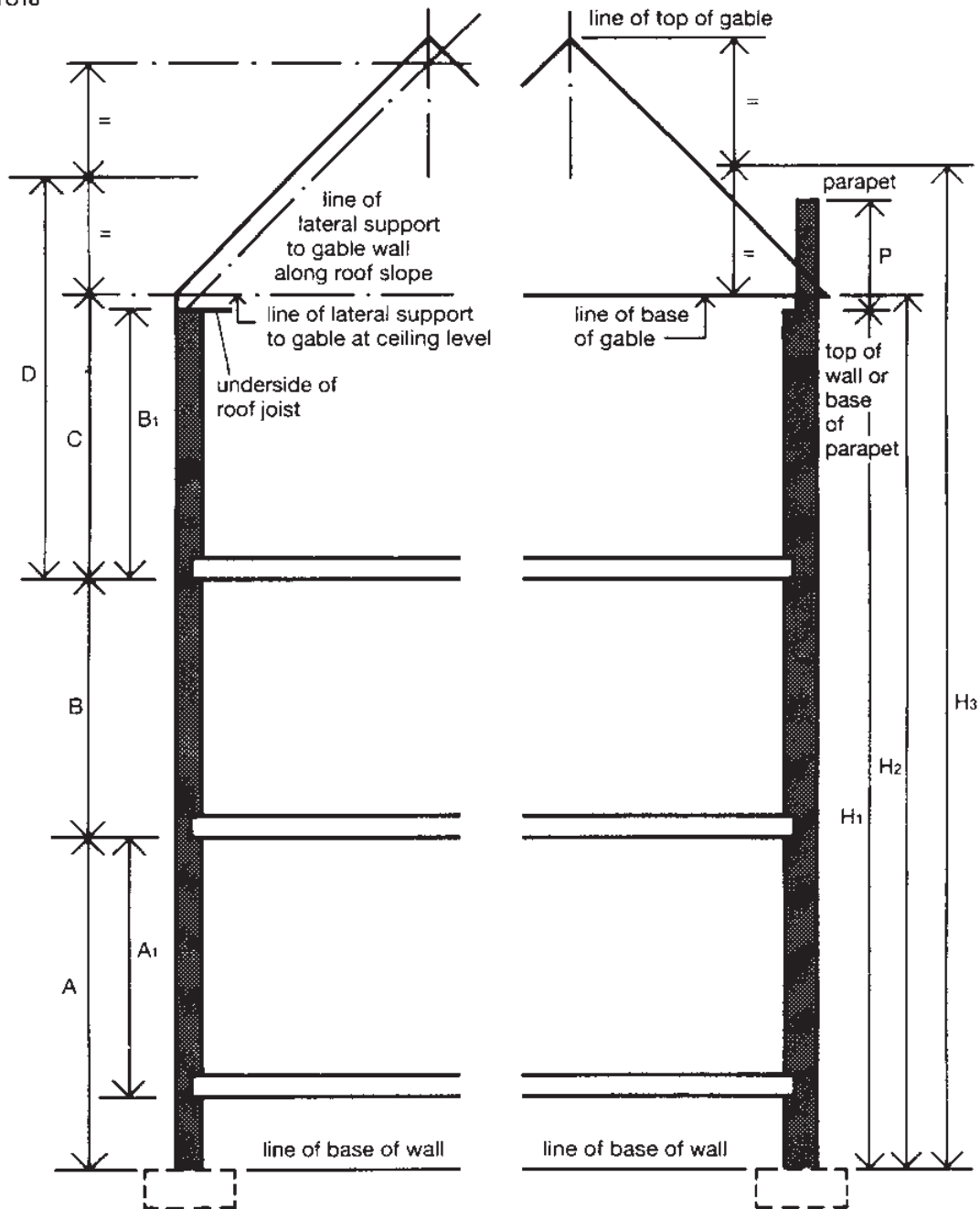

Key

(a) Measuring storey heights

- A** is the ground storey height if the ground floor is a suspended timber floor or a structurally separate ground floor slab
- A₁** is the ground storey height if the ground floor is a suspended concrete floor bearing on the external wall
- B** is the intermediate storey height
- B₁** is the top storey height for walls which do not include a gable
- C** is the storey height where lateral support is given to the gable at both ceiling level and along the roof slope
- D** is the storey height for walls which include a gable where lateral support is given to the gable along the roof slope

(b) Measuring wall heights

- H₁** is the height of a wall that does not include a gable
- H₂** is the height of compartment or separating wall which may extend up to the underside of the roof
- H₃** is the height of a wall (except a compartment or separating wall) which includes a gable
- P** if the parapet height is more than 1.2m the height should be added to H₁.

Diagram 10 Compressive strength of brick and block units

See para 1C21

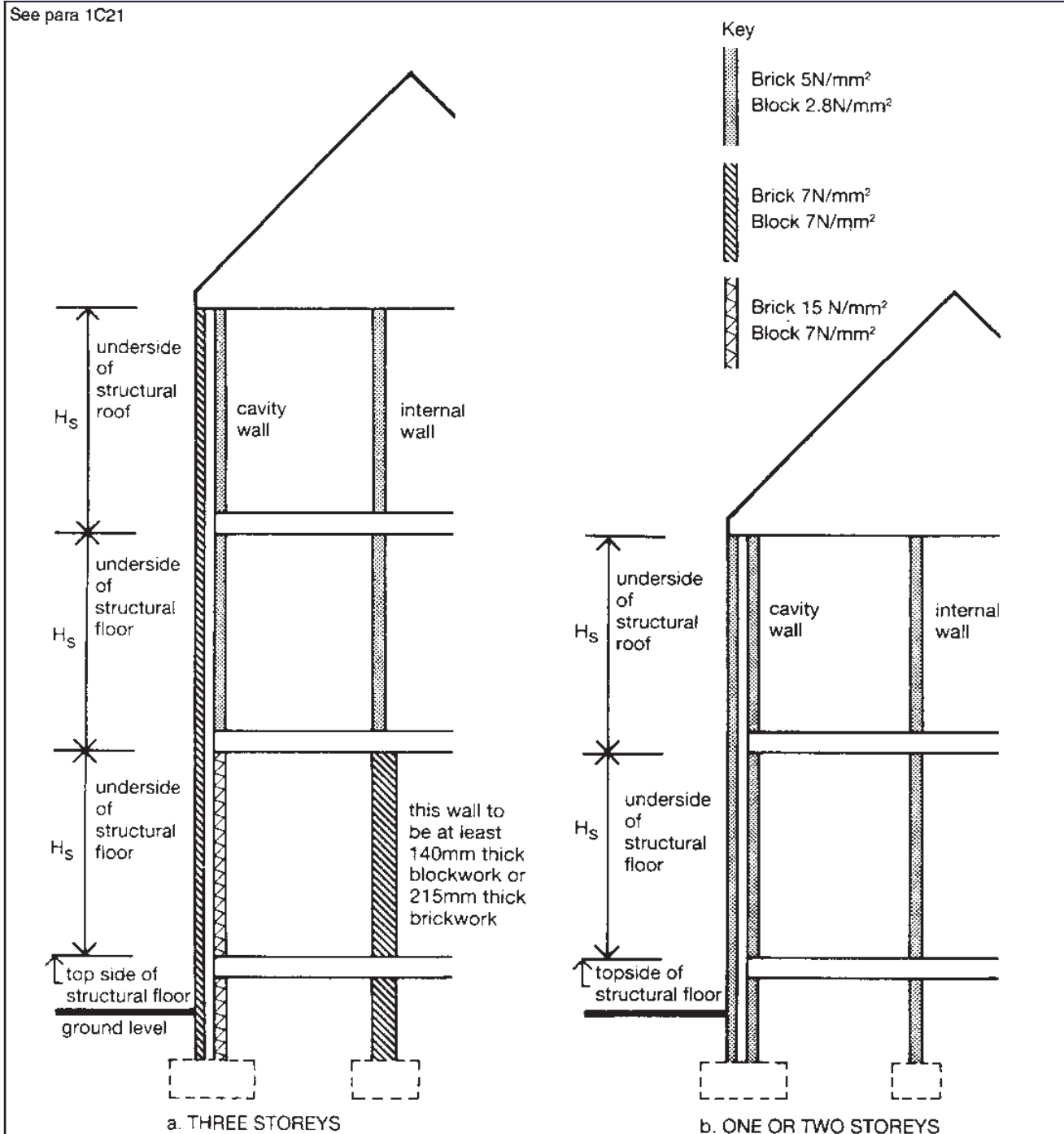

Notes

1 If H_s is not greater than 2.7m, the compressive strength of bricks or blocks should be used in walls as indicated by the key.

2 If H_s is greater than 2.7m, the compressive strength of bricks or blocks used in the wall shall either be at least 7N/sq mm or as indicated by the key, whichever is the greater.

3 If the external wall is solid construction, the bricks or blocks should have a compressive strength of at least that shown for the internal leaf of a cavity wall in the same position.

4 The guidance given in the diagram should only be used to determine the compressive strength of brick and block units for walls of two and three storey buildings where the roof construction is of timber.

1C21 Compressive strength of bricks and blocks: Bricks and blocks, when tested in accordance with the appropriate British Standard, should have a compressive strength not less than the values given in Diagram 10.

1C22 Mortar: Mortar should be:

- a. to the proportions—
 - i. given in BS 5628: Part 1: 1978 mortar designation (iii), or
 - ii. 1:1:6 Portland Cement, line and fine aggregate measured by volume of dry materials, or
- b. of equivalent or where appropriate of greater strength, which is compatible with the masonry units and position of use.

Loading on walls

1C23 Maximum span of floors: The maximum span for any floor supported by a wall is 6m where the span is measured centre to centre of bearing. (See Diagram 11).

1C24 Other loading conditions:

a. Vertical loading on walls should be distributed. This may be assumed for concrete floor slabs, precast concrete floors, and timber floors designed in accordance with Section 1B, and where the bearing length for lintels is 150mm or greater. Where a lintel has a clear span of 1200mm or less the bearing length may be reduced to 100mm.

Diagram 11 Maximum span of floors

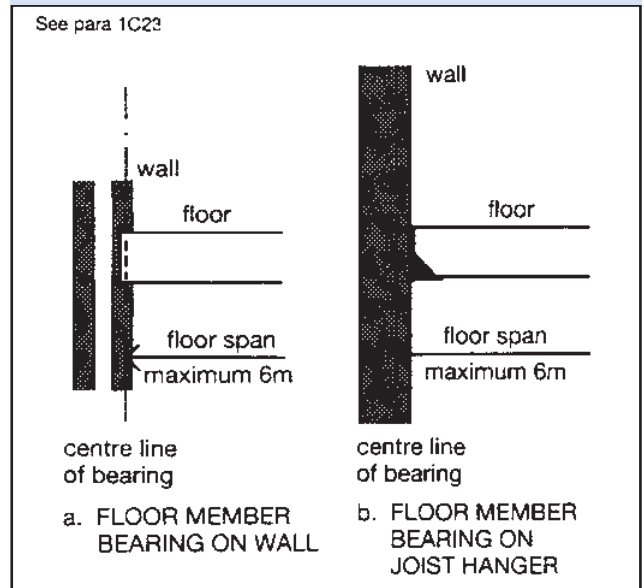

b. differences in level ground or other solid construction between one side of the wall and the other should be less than 4 times the thickness of the wall as shown in Diagram 12.

c. The combined dead and imposed load should not exceed 70 kN/m at base of wall. (See Diagram 12).

d. Walls should not be subjected to lateral load other than from wind, and that covered by paragraph 1C24(b).

Diagram 12 Difference in ground level

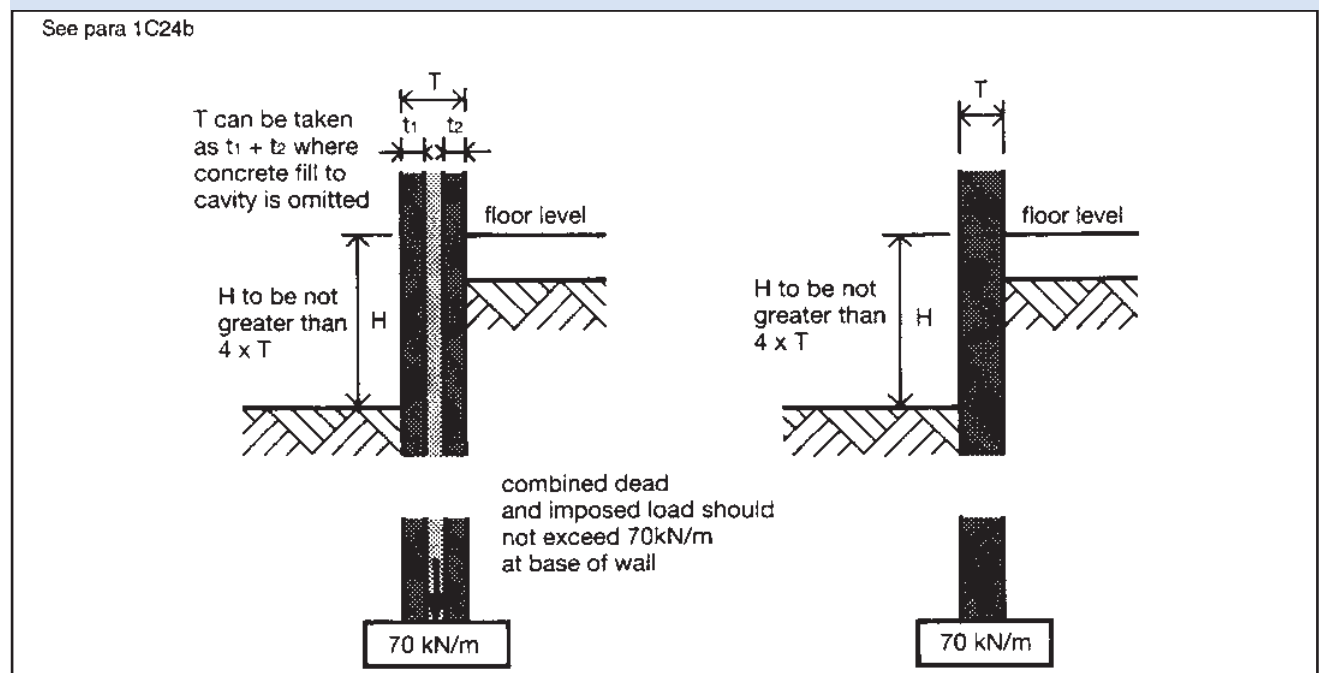

End restraint

1C25 Buttreassing walls piers and chimneys:

The ends of every wall, except single leaf walls less than 2.5m in storey height and length in small single storey non-residential buildings and annexes should be bonded or otherwise securely tied throughout their full height to a buttressing wall, pier or chimney. Long walls may be provided with intermediate support, dividing the wall into distinct lengths; each distinct length is a supported wall for the purposes of this section. The buttressing wall, pier or chimney should provide support from the base to the full height of the wall.

1C26 Design criteria for buttressing walls:

Diagram 13 gives guidance for buttressing walls. Additionally if the buttressing wall is not itself a supported wall its thickness T_2 should not be less than:

- a. half the thickness required by this section for an external or separating wall of similar height and length less 5mm, or
- b. 75mm if the wall forms part of a dwellinghouse and does not exceed 6m in total height and 10m in length, and
- c. 90mm in any other cases.

Diagram 13 Openings in a buttressing wall

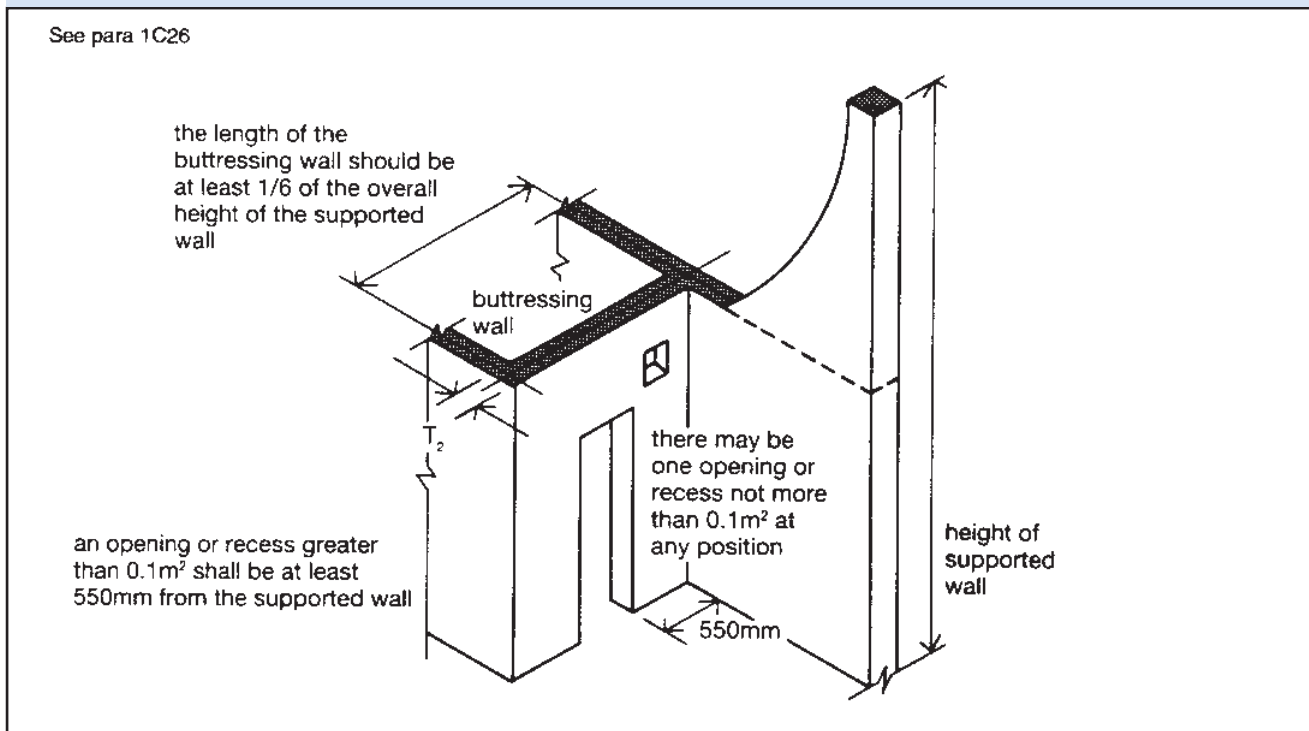

Notes

- 1 The buttressing wall should be bonded or securely tied to the supported wall and at the other end to a buttressing wall, pier or chimney.
- 2 Openings or recesses in the buttressing wall should

- be shown – the position and shape of the openings should not impair the lateral support to be given by the buttressing wall.
- 3 Refer to Diagram 11 for the rules for measuring the height of the supported wall.

1C27 Design criteria for piers and chimneys providing restraint:

- a. piers should measure at least 3 times the thickness of the supported wall and chimneys twice the thickness, measured at right angles to the wall. Piers should have a minimum width of 190mm (see Diagram 14).
- b. The sectional area on plan of chimneys (excluding openings for fireplaces and flues) should be not less than the area required for a pier in the same wall, and the overall thickness should not be less than twice the required thickness of the supported wall. (See Diagram 14).

Diagram 14 Buttrressing

See para 1C27

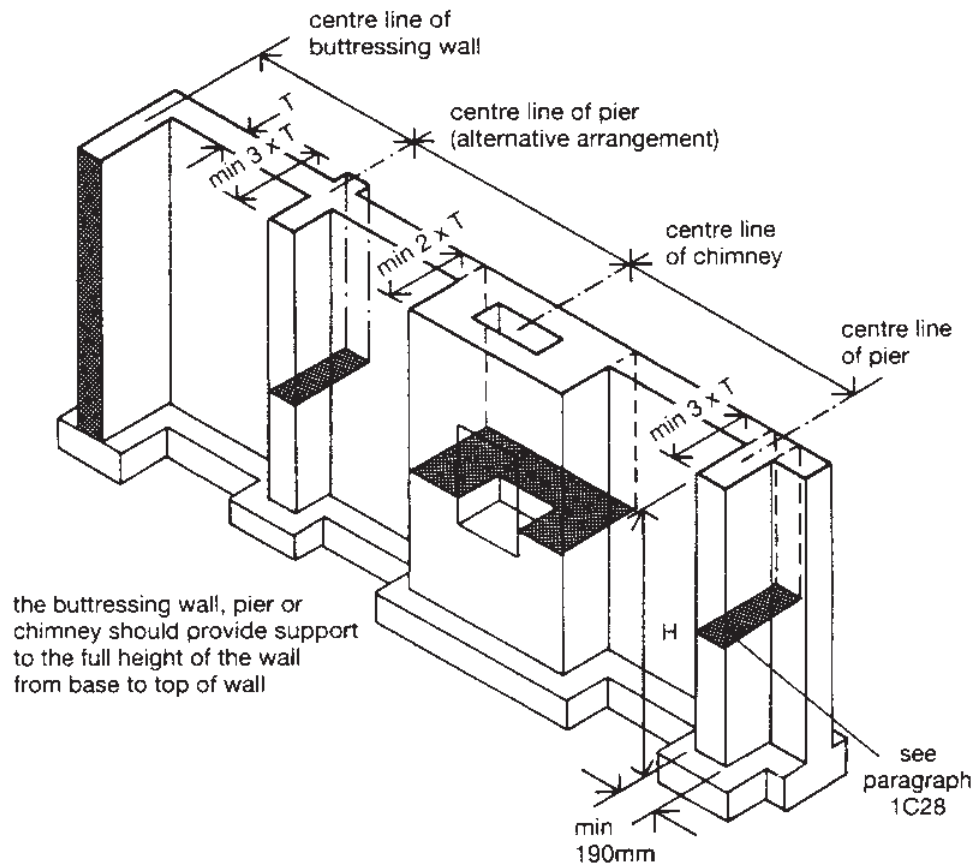

Openings, recesses, overhangs and chases

1C28 General: The number, size and position of openings and recesses should not impair the stability of a wall or the lateral support afforded by a buttressing wall to a supported wall. Construction over openings and recesses should be adequately supported.

1C29 Dimensional criteria for openings and recesses: The dimensional criteria are given in Diagram 15 and Table 8.

1C30 Chases:

- vertical chases should not be deeper than 1/3 of the wall thickness or, in cavity walls, 1/3 of the thickness of the leaf
- horizontal chases should not be deeper than 1/6 of the thickness of the leaf or wall
- chases should not be so positioned as to impair the stability of the wall, particularly where hollow blocks are used.

1C31 Overhangs: The amount of any projection should not impair the stability of the wall

Diagram 15 Sizes of openings and recesses

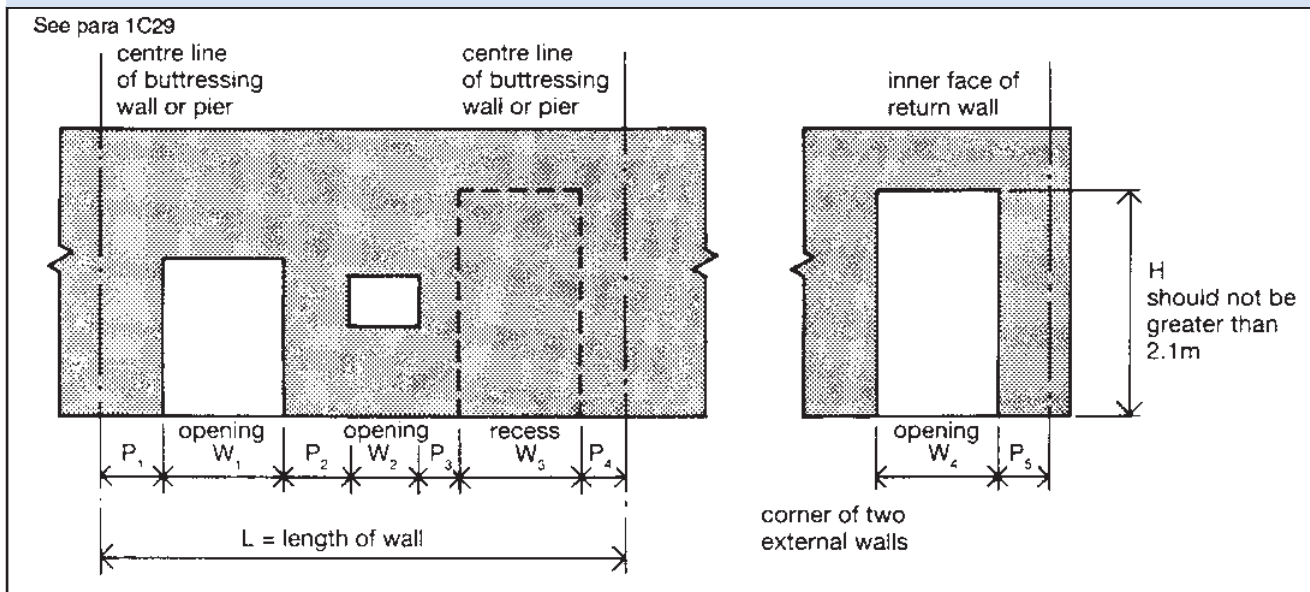

Notes

Requirements (refer to Table 8 for values of factor X).

1 $W_1 + W_2 + W_3$ should not exceed $\frac{2L}{3}$

2 W_1, W_2 or W_3 should not exceed 3m

3 P_1 should be greater than or equal to $\frac{W_1}{X}$

4 P_2 should be greater than or equal to $\frac{W_1 + W_2}{X}$

5 P_3 should be greater than or equal to $\frac{W_2 + W_3}{X}$

6 P_4 should be greater than or equal to $\frac{W_1}{X}$

7 P_5 should be greater than or equal to $\frac{W_4}{X}$ but should not be less than 385mm

8 Take the value of the factor X from Table 8 or it can be given the value 6, provided the compressive strength of the bricks or blocks (in the case of a cavity wall – in the loaded leaf) is not less than $7n/\text{mm}^2$.

Table 8 Value of factor 'x' (see Diagram 15)

Nature of roof span	Maximum roof span (m)	Minimum thickness of wall inner leaf (m)	Span of floor is parallel to wall	Span of timber floor into wall		Span of concrete floor into wall	
				max 4.5m	max 6.0m	max 4.5m	max 6.0m
Value of factor. 'x'							
roof spans parallel to wall	not applicable	100	6	6	6	6	6
timber roof spans into wall	9	100	6	6	5	4	3
		90	6	4	4	3	3

Lateral support by roofs and floors

1C32 A wall in each storey of a building should extend to the full height of that storey, and have horizontal lateral supports to restrict movement of the wall at right angles to its plane.

1C33 Floors and roofs should:

- act to transfer lateral forces from walls to buttressing walls, piers or chimneys, and
- be secured to the supported wall by connections specified in paragraphs 1C34 and 1C35.

1C34 The requirements for lateral restraint of walls at roof and floor levels are given in Table 9 and guidance on satisfying the requirements is given in paragraphs 1C35 and 1C36.

Table 9 Lateral support for walls

Wall type	Wall length	Lateral support required
solid or cavity: external compartment separating	any length	roof lateral support by every roof forming a junction with the supported wall
	greater than 3m	floor lateral support by every floor forming a junction with the supported wall
internal load-bearing wall (not being a compartment or separating wall)	any length	roof or floor lateral support at the top of each storey

Diagram 16 Lateral support by floors

See para 1C35

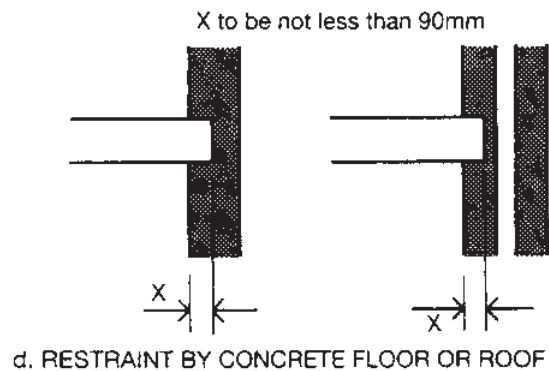
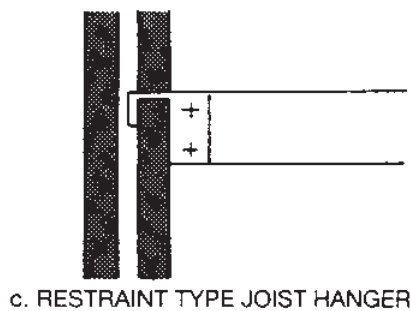
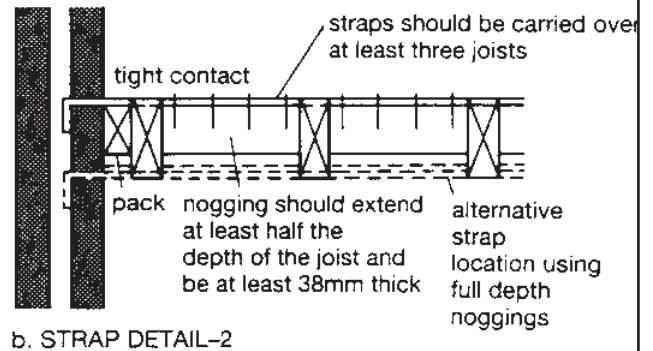
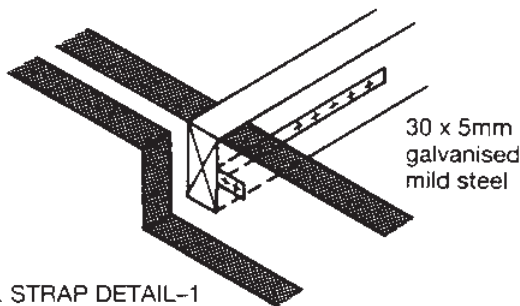

where contact between floors and walls on both sides of the wall is at intervals no greater than 2m

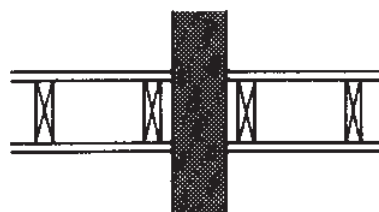

floors should be at or about the same level on each side of the wall. Where lateral support is intermittent, the point of contact should be in line or nearly in line

1C35 Walls should be strapped to floors above ground level, at intervals not exceeding 2m and as shown in Diagram 16 by galvanised mild steel or other durable metal straps which have a minimum cross-section of 30mm x 5mm.

Straps need not be provided:

- in the longitudinal direction of joists in houses of not more than 2 storeys, if the joists are at not more than 1.2m centres and have at least 90mm bearing on the supported walls or 75mm bearing on a timber wall-plate at each end, and
- in the longitudinal direction of joists in houses of not more than 2 storeys, if the joists are carried on the supported wall by joist hangers of the restraint type described in BS 5628: Part 1 and shown in Diagram 16(c), and are incorporated at not more than 2m centres, and
- when a concrete floor has at least 90mm bearing on the supported wall (see Diagram 16(d)), and
- where floors are at or about the same level on each side of a supported wall, and contact

between the floors and wall is either continuous or at intervals not exceeding 2m. Where contact is intermittent, the points of contact should be in line or nearly in line on plan. (See Diagram 16(e)).

1C36 Gable walls should be strapped to roofs as shown in Diagram 17(a) and (b) by galvanised mild steel or other durable metal straps which have a minimum cross-section of 30mm x 5mm.

Vertical strapping at least 1m in length should be provided at eaves level at intervals not exceeding 2m as shown in Diagram 17(c) and (d). Vertical strapping may be omitted if the roof:

- has a pitch of 15° or more, and
- is tiled or slated, and
- is of a type known by local experience to be resistant to wind gusts, and
- has main timber members spanning onto the supported wall at not more than 1.2m centres.

Diagram 17 Lateral support at roof level

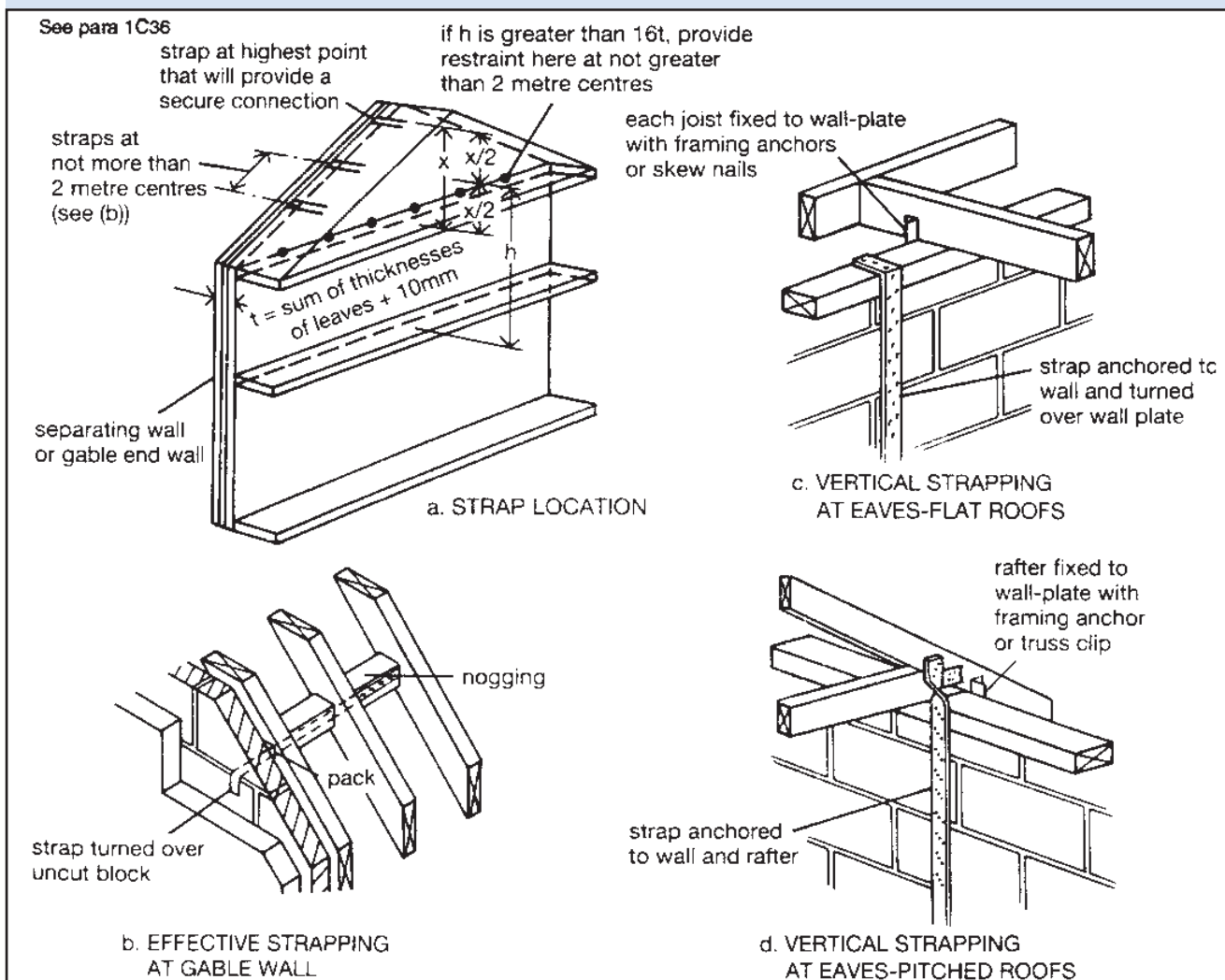

Interruption of lateral support

1C37 Where an opening in a floor or roof for a stairway or the like adjoins a supported wall and interrupts the continuity of lateral support, the following conditions should be satisfied for the purposes of Section 1C:

- a. the maximum permitted length of the opening is to be 3m, measured parallel to the supported wall, and
- b. where a connection is provided by means other than by anchor, this should be provided throughout the length of each portion of the wall situated on each side of the opening, and
- c. where connection is provided by mild steel anchors, these should be spaced closer than 2m on each side of the opening to provide the same number of anchors as if there were no opening, and
- d. there should be no other interruption of lateral support.

External walls of small single storey non-residential buildings and annexes

1C38 Single leaf external walls which:

- a. enclose a floor area not exceeding 36m²
- b. are of solid construction in bricks and blocks of 90mm minimum thickness, and
- c. are not subject to any load other than wind load and the distributed load of the roof of the small building or annexe, and
- d. are greater than 2.5m in length or height, should be bonded at each end and intermediately to buttressing walls or piers of size and spacing as shown in Diagram 18.

Diagram 18 Pier size and spacing

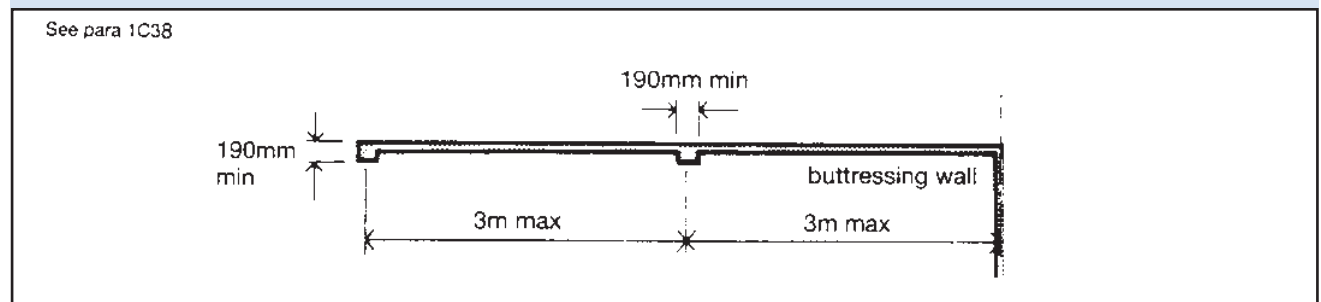

Section 1D

PROPORTIONS FOR MASONRY CHIMNEYS ABOVE THE ROOF SURFACE

Height to width relationship

1D1 Where a chimney is not adequately supported by ties or securely restrained in any way, its height if measured from the highest point of intersection with the roof surface, gutter, etc. should not exceed $4.5 W$, provided the density of the masonry is greater than 1500 kg/m^3 , where:

W is the least horizontal dimension of the chimney measured at the same point of intersection, and

H is measured to the top of any chimney pot or other flue terminal. (See diagram 19).

Diagram 19 Proportions for masonry chimneys

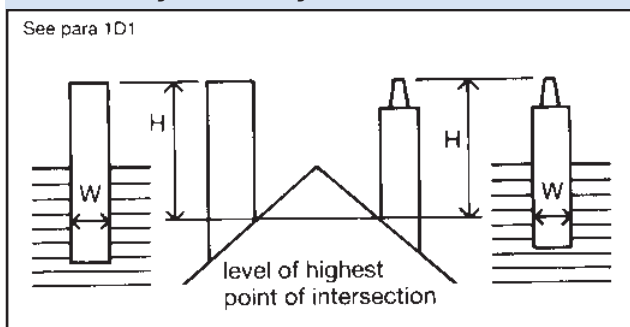

Section 1E

STRIP FOUNDATIONS OF PLAIN CONCRETE

Conditions relating to the sub-soil

1E1 There should not be:

- made ground or wide variation in type of subsoil within the loaded area, nor
- weaker type of soil at such a depth below the soil on which the foundation rests as could impair the stability of the structure.

Design provisions

1E2 The following design provisions relate to foundations:

- the foundations should be situated centrally under the wall.
- Strip foundations should have the minimum widths given in Table 10.
- For foundations in chemically aggressive soil conditions guidance in BS 5328: Part 1 should be followed. In non-aggressive soils, concrete should be composed of cement to BS 12: 1989 and fine and coarse aggregate conforming to BS 882: 1983 and the mix should comply with one of the following recommendations:
 - In proportion of 50 kg of cement to not more than 0.1m^3 of fine aggregate and 0.2m^3 of coarse aggregate, or
 - Grade ST1 concrete to BS 5328: Part 2
- minimum thickness T of concrete foundation should be 150mm or P , whichever is the greater where P is derived using Table 10. (See Diagram 22 a. and b.).
- foundations stepped on elevation should overlap by twice the height of the step, by the thickness of the foundation, or 300mm, whichever is greater. (See Diagram 20).
- Steps in foundations should not be of greater height than the thickness of the foundation. (See diagram 20).
- Foundation of piers, buttresses and chimneys should project as indicated in Diagram 21 and the projection X should never be less than P .

Diagram 20 Elevation of stepped foundation

See para 1E2e. and f.

foundations should unite at each change in level

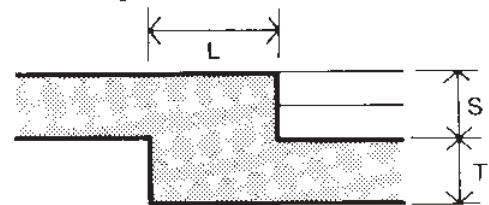

minimum overlap L = twice height of step, or thickness of foundation or 300mm, whichever is greater

S should not be greater than T

Diagram 21 Piers and chimneys

See para 1E2g

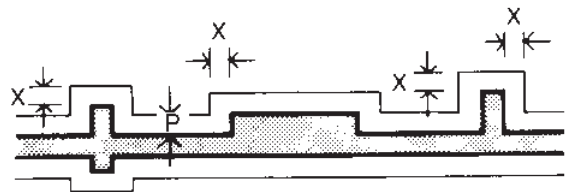

projection X should not be less than P

Minimum width of strip foundations

1E3 Providing the previous conditions relating to the subsoil (paragraph 1E1) and design provisions relating to the foundations (paragraph 1E2) are observed, and the type and condition of subsoil is known, and loading at the base of the wall is within acceptable limits, the recommended widths of foundations given in Table 10 may be used.

Table 10 Minimum width of strip foundations

Type of subsoil	Condition of subsoil	Field test applicable	Total load of load-bearing walling not more than [kN/linear metre]					
			20	30	40	50	60	70
I rock	not inferior to sandstone, limestone or firm chalk	requires at least a pneumatic or other mechanically operated pick for excavation	Minimum width of strip foundation (mm)					in each case equal to the width of wall
II gravel sand	compact compact	requires pick for excavation. Wooden peg 50mm square in cross section hard to drive beyond 150mm	250	300	400	500	600	650
III clay sandy clay	stiff stiff	cannot be moulded with the fingers and requires a pick or pneumatic or other mechanically operated spade for its removal	250	300	400	500	600	650
IV clay sandy clay	firm firm	can be moulded by substantial pressure with the fingers and can be excavated with graft or spade	300	350	450	600	750	850
V sand silty sand clayey sand	loose loose loose	can be excavated with a spade. Wooden peg 50mm square in cross section can be easily driven	400	600	Note In relation to types V, VI and VII foundation do not fall within the provisions of this section if the total load exceeds 30kN/m.			
VI silt clay sandy clay silty clay	soft soft soft	fairly easily moulded in the fingers and readily excavated	450	650				
VII silt clay sandy clay silty clay	very soft very soft very soft	natural sample in winter conditions exudes between fingers when squeezed in fist	600	850				

Diagram 22 Foundation dimensions

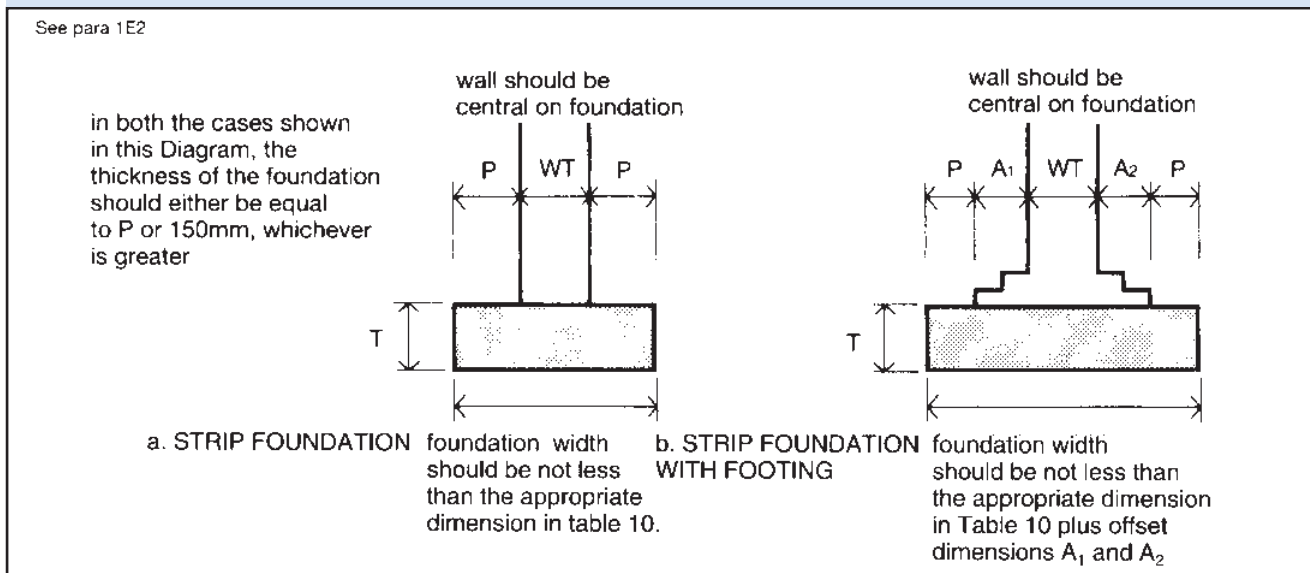

Section 2

RE-COVERING OF ROOFS

New roof coverings may impose substantially higher loads on the roof structure compared to the original ones. Occasionally, the new material may be substantially lighter than the original material. In both cases the following procedure is recommended.

- a. Compare the loading imposed by the proposed roof covering the original roof loading. (In calculating the loading allowance should be made for the increase in load due to water absorption e.g. 0.3% for oven dry slates and up to 10.5% for clay plain tiles and concrete tiles based on dry mass per unit area of roof coverings.
- b. Arrange for inspection of the existing roof structure and check whether:
 - i. roof structure is capable of sustaining the increased load, or
 - ii. the vertical restraints are adequate for the wind uplift which may result due to the use of lighter roof material and/or provision of new underlay
- c. Provide appropriate strengthening measures such as:
 - i. replacement of defective members, fixings (including nails) and vertical restraints;
 - ii. provision of additional structural members, e.g. trusses, rafters, bracing, purlins etc., as may be required to sustain the increased loading;
 - iii. provision of restraining straps, additional ties and fixings to the walls, as may be required to resist the wind uplift.

Section 3

CODES, STANDARDS AND REFERENCES FOR REQUIREMENTS (1) AND (2) OF PART 1

Introduction

4.1 This Section is relevant to all building types and lists codes, standards and other references for structural design and construction.

References

4.2 Loading

a. Dead and imposed loads

BS 6399: *Loading for buildings:*

Part 1: 1984 *Code of practice for dead and imposed loads.*

b. Imposed roof loads

BS 6399: *Loading for buildings:*

Part 3: 1988 *Code of practice for imposed roof loads.*

c. Wind loads

CP3: Code of basic data for the design of buildings:

Chapter V: *Loading:* Part 2: 1972 *Wind loads* (although in no case should the factor S_3 be taken as less than 1).

Exceptionally where the actual load is greater than BS 6399: Part 1: 1984 design loads, the actual load should be used having regard to Section 3 of this Technical Guidance Document.

4.3 Structural work of timber

BS 5268: *Structural use of timber:*

Part 2: 1991 *Code of practice for permissible stress design, materials and workmanship.*

Part 3: 1985 *Code of practice for trussed rafter roofs.*

4.4 Structural work of masonry

BS 5628: *Code of practice for use of masonry:*

Part 1: 1978 *Structural use of unreinforced masonry.*

Part 3: 1985 *Materials and components, design and workmanship.*

4.5 Structural work of reinforced, pre-stressed or plain concrete

BS 8110: *Structural use of concrete:*

Part 1: 1985 *Code of practice for design and construction.*

Part 2: 1985 *Code of practice for special circumstances.*

Part 3: 1985 *Design charts for singly reinforced beams, doubly reinforced beams and rectangular columns.*

4.6 Structural work of steel

BS 5950: *Structural use of steelwork in buildings:*

Part 1: 1990 *Code of practice for design in simple and continuous construction: hot rolled sections.*

Part 2: 1992 *Specification for materials, fabrication and erection: hot rolled sections.*

Part 3: *Design in composite construction:*

Section 3.1: 1990 *Code of practice for design of simple and continuous composite beams.*

Part 4: 1982 *Code of practice for design of floors with profiled steel sheeting.*

Part 5: 1987 *Code of practice for design of cold formed sections.*

BS 449: *Specification for the use of structural steel in building:*

Part 2: 1969 *Metric units.*

4.7 Structural work of aluminium

CP 118: 1969: *The structural use of aluminium*

(using one of the principal or supplementary aluminium alloys designated in Section 1.1 of that code, and for the purpose of section 5.3 of that code, the structure should be classified as safe-life structure).

4.8 Foundations

BS 8004: 1986 *Code of practice for foundations.*

Existing buildings

4.9 Compliance with Part 1 (structure) is required in certain classes of change of use of a building. See Bye-Law 6. Guidance relevant to structural appraisals related to 'change of use' is given in the following documents:

a. *BRE Digest 366: Structural Appraisal of Existing Buildings for Change of Use.*

b. The Institution of Structural Engineers Report *Appraisal of Existing Structures, 1980.*

Note: With reference to the item 'design checks' in the above mentioned Institution of Structural Engineers report the choice of various partial factors should be made to suit the individual circumstances of each case. For BS Codes and Standards quoted in the report the latest versions referred to in this Technical Guidance Document should be used.

Guidance

Performance

In the view of the Committee requirement 3 of Part 1 will be met by an appropriate choice of measures:

- a. to avoid or reduce the hazards to which the building may be exposed;
- b. to reduce the sensitivity of the building to disproportionate collapse should an accident occur.

Introduction

0.3 The guidance in Section 4 deals with the means of reducing the sensitivity of the building to disproportionate collapse in the event of an accident.

Section 4

REDUCING THE SENSITIVITY OF THE BUILDING TO DISPROPORTIONATE COLLAPSE IN THE EVENT OF AN ACCIDENT

4.1 The requirement will be met by adopting the following approach:

a. Provide effective horizontal and vertical ties in accordance with the recommendations given in the Codes and Standards listed under paragraph 4.2 below. If these measures are followed no further action is likely to be necessary.

b. If effective horizontal tying is provided and it is not feasible to provide effective vertical tying of any of the vertical loadbearing members, then each such untied member should be considered to be notionally removed, one at a time in each storey in turn, to check that its removal would allow the rest of the structure to bridge over the missing member albeit in a substantially deformed condition.

In considering this option, it should be recognised that certain areas of the structure

(e.g. cantilevers or simply supported floor panels etc.) will remain vulnerable to collapse. In these instances, the area at risk of collapse of the structure should be limited to that given under paragraph 4.1c below.

If it is not possible to bridge over the missing member, that member should be designed as a protected member (see paragraph 4.1d below).

c. If it is not feasible to provide effective horizontal and vertical tying of any of the loadbearing members, then each support member should be considered to be notionally removed, one at a time in each storey in turn, to check that, on its removal the area at risk of collapse of the structure within the storey and the immediately adjacent storeys is limited to

- i. 15% of the area of the storey or
- ii 70m²

whichever is the less (see Diagram 23). It should be noted that the area at risk is the area of the floor at risk of collapse on the removal of the member and not necessarily the entire area supported by the member in conjunction with other members.

Diagram 23 Area at risk of collapse in the event of an accident

See para 4.1c

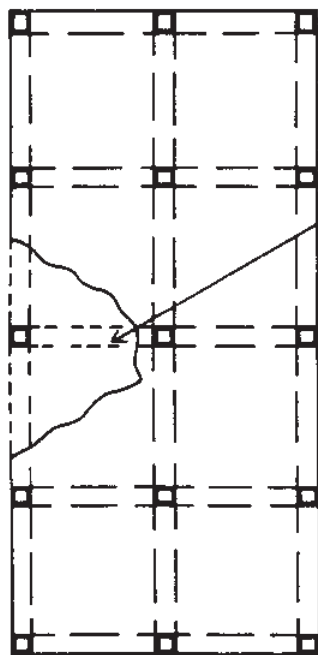

PLAN

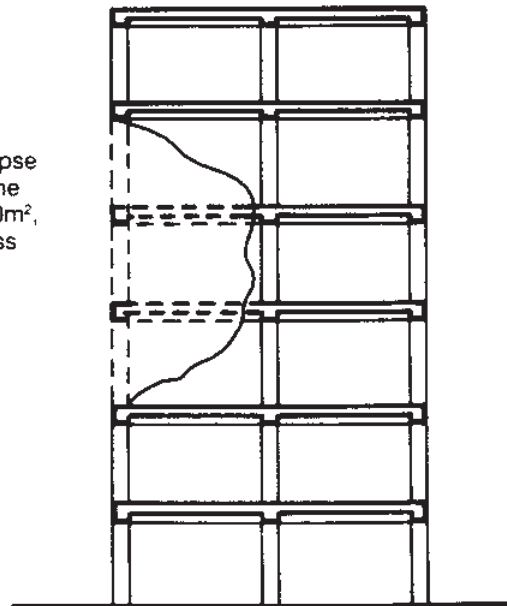

SECTION

If, on removal of a member, it is not possible to limit the area put at risk of collapse as above, that member should be designed as a protected member. (See paragraph 4.1d).

d. **Design of protected members:** The protected members (sometimes called 'key' elements) should be designed in accordance with the recommendations given in the appropriate Codes and Standards listed in paragraph 4.2.

Alternative approach

4.2 The performance can also be met by following the relevant recommendations given in the clauses of the Codes and Standards listed below:

Structural work of masonry: Clause 37 of BS 5628: *Code of practice for use of masonry* Part 1: 1978 *Structure use of unreinforced masonry*.

Structural work of steel: Clause 2.4.5.3 of BS 5950: *Structural use of steelwork in building* Part 1: 1990 *Code of practice for design in simple and continuous construction: hot rolled Sections*. (The accidental loading referred to in clause 2.4.5.5 should be chosen having particular regard to the importance of the key element and the consequences of failure, and the key element should always be capable of withstanding a load of at least 34 kN/m² applied from any direction.)

Structural work of reinforced, prestressed or plain concrete: Clause 2.2.2.2 of BS 8110 *Structural use of concrete*. Part 1: 1985 *Code of practice for design and construction*, and Clause 2.6 of part 2: 1985 *Code of practice for special circumstances*.

Appendix A

TABLES OF SIZES OF TIMBER FLOOR, CEILING, AND ROOF MEMBERS IN SINGLE FAMILY HOUSES

A1 This Appendix must be used in conjunction with Sections 1A and 1B.

A2 This section sizes given in these tables for floor ceiling and flat roof joists are either regularised from BS 4471 basic sawn sizes in accordance with the requirements and tolerances of BS 4471 or CLS/ALS sizes with BS 4471 tolerances.

The section sizes for ceiling binders and roof members – including purlins for sheeting – are either BS 4471 or CLS/ALS sizes with the tolerances of BS 4471 or CLS/ALS sizes with BS 4471 tolerances.

A3 All spans except those for floorboards are measured as the clear dimension between supports and all spacings are the dimensions between longitudinal centres of members.

Table A1 Floor joists

Maximum clear span of joist (m) Timber of strength class SC3 (see Table 1)

Size of joist (mm x mm)	Dead Load [kN/m ²] excluding the self weight of the joist								
	Not more than 0.25			More than 0.25 but not more than 0.50			More than 0.50 but not more than 1.25		
	Spacing of joists (mm)								
	400	450	600	400	450	600	400	450	600
38 x 97	1.83	1.69	1.30	1.72	1.56	1.21	1.42	1.30	1.04
38 x 122	2.48	2.39	1.93	2.37	2.22	1.76	1.95	1.79	1.45
38 x 147	2.98	2.87	2.51	2.85	2.71	2.33	2.45	2.29	1.87
38 x 170	3.44	3.31	2.87	3.28	3.10	2.69	2.81	2.65	2.27
38 x 195	3.94	3.75	3.26	3.72	3.52	3.06	3.19	3.01	2.61
38 x 220	4.43	4.19	3.65	4.16	3.93	3.42	3.57	3.37	2.92
47 x 97	2.02	1.91	1.58	1.92	1.82	1.46	1.67	1.53	1.23
47 x 122	2.66	2.56	2.30	2.55	2.45	2.09	2.26	2.08	1.70
47 x 147	3.20	3.08	2.79	3.06	2.95	2.61	2.72	2.57	2.17
47 x 170	3.69	3.55	3.19	3.53	3.40	2.99	3.12	2.94	2.55
47 x 194	4.22	4.06	3.62	4.40	3.89	3.39	3.54	3.34	2.90
47 x 220	4.72	4.57	4.04	4.55	4.35	3.79	3.95	3.74	3.24
50 x 97	2.08	1.97	1.67	1.98	1.87	1.54	1.74	1.60	1.29
50 x 122	2.72	2.62	2.37	2.60	2.50	2.19	2.33	2.17	1.77
50 x 147	3.27	3.14	2.86	3.13	3.01	2.69	2.81	2.65	2.27
50 x 170	3.77	3.62	3.29	3.61	3.47	3.08	3.21	3.03	2.63
50 x 195	4.31	4.15	3.73	4.13	3.97	3.50	3.65	3.44	2.99
50 x 220	4.79	4.66	4.17	4.64	4.47	3.91	4.07	3.85	3.35
63 x 97	2.32	2.20	1.92	2.19	2.08	1.82	1.93	1.84	1.53
63 x 122	2.93	2.82	2.57	2.81	2.70	2.45	2.53	2.43	2.09
63 x 147	3.53	3.39	3.08	3.37	3.24	2.95	3.04	2.92	2.58
63 x 170	4.06	3.91	3.56	3.89	3.74	3.40	3.50	3.37	2.95
63 x 195	4.63	4.47	4.07	4.44	4.28	3.90	4.01	3.85	3.35
63 x 220	5.06	4.92	4.58	4.91	4.77	4.37	4.51	4.30	3.75
75 x 122	3.10	2.99	2.72	2.97	2.86	2.60	2.68	2.58	2.33
75 x 147	3.72	3.58	3.27	3.56	3.43	3.13	3.22	3.09	2.81
75 x 170	4.28	4.13	3.77	4.11	3.96	3.61	3.71	3.57	3.21
75 x 195	4.83	4.70	4.31	4.68	4.52	4.13	4.24	4.08	3.65
75 x 220	5.27	5.13	4.79	5.11	4.97	4.64	4.74	4.60	4.07
38 x 140	2.84	2.73	2.40	2.72	2.59	2.17	2.33	2.15	1.75
38 x 184	3.72	3.56	3.09	3.53	3.33	2.90	3.02	2.85	2.47
38 x 235	4.71	4.46	3.89	4.43	4.18	3.64	3.80	3.59	3.11

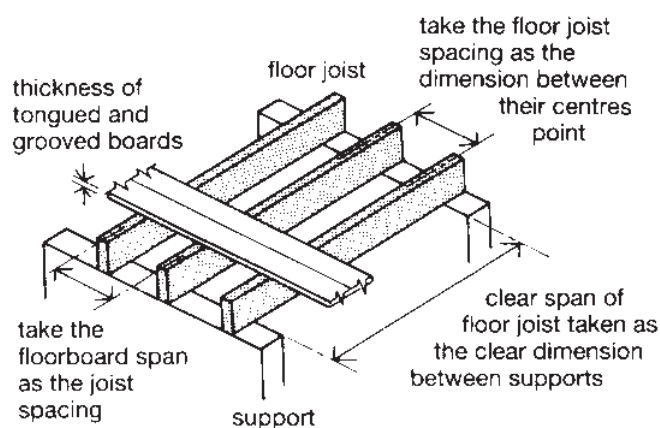

Notes to Table A1 and A2

1 Softwood tongued and grooved floorboards if supported at a joist spacing of up to 500mm should be at least 16mm finished thickness; and if supported at wider spacings up to 600mm should be 19mm finished thickness.

2 The sizes, spacings and spans given will support the dead loads stated in the tables, and an imposed load not exceeding 1.5 kN/m². (These tables can be used when a bath is to be installed provided joists supporting the bath are duplicated.)

Table A2 Floor joists

Maximum clear span of joist (m) Timber of strength class SC4 (see Table 1)

Size of joist (mm x mm)	Dead Load [kN/m ²] excluding the self weight of the joist								
	Not more than 0.25			More than 0.25 but not more than 0.50			More than 0.50 but not more than 1.25		
	Spacing of joists (mm)								
	400	450	600	400	450	600	400	450	600
38 x 97	1.94	1.83	1.59	1.84	1.74	1.51	1.64	1.55	1.36
38 x 122	2.58	2.48	2.20	2.47	2.37	2.08	2.18	2.07	1.83
38 x 147	3.10	2.98	2.71	2.97	2.85	2.59	2.67	2.56	2.31
38 x 170	3.58	3.44	3.13	3.43	3.29	2.99	3.08	2.96	2.68
38 x 195	4.10	3.94	3.58	3.92	3.77	3.42	3.53	3.39	3.07
38 x 220	4.61	4.44	4.03	4.41	4.25	3.86	3.97	3.82	3.46
47 x 97	2.14	2.03	1.76	2.03	1.92	1.68	1.80	1.71	1.50
47 x 122	2.77	2.66	2.42	2.65	2.55	2.29	2.38	2.27	2.01
47 x 147	3.33	3.20	2.91	3.19	3.06	2.78	2.87	2.75	2.50
47 x 170	3.84	3.69	3.36	3.67	3.54	3.21	3.31	3.18	2.88
47 x 195	4.39	4.22	3.85	4.20	4.05	3.68	3.79	3.64	3.30
47 x 220	4.86	4.73	4.33	4.71	4.55	4.14	4.26	4.10	3.72
50 x 97	2.20	2.09	1.82	2.08	1.98	1.73	1.84	1.75	1.54
50 x 122	2.83	2.72	2.47	2.71	2.60	2.36	2.43	2.33	2.06
50 x 147	3.39	3.27	2.97	3.25	3.13	2.84	2.93	2.81	2.55
50 x 170	3.91	3.77	3.43	3.75	3.61	3.28	3.38	3.25	2.94
50 x 195	4.47	4.31	3.92	4.29	4.13	3.75	3.86	3.72	3.37
50 x 220	4.93	4.80	4.42	4.78	4.64	4.23	4.35	4.18	3.80
63 x 97	2.43	2.32	2.03	2.31	2.19	1.93	2.03	1.93	1.71
63 x 122	3.05	2.93	2.67	2.92	2.81	2.55	2.63	2.53	2.27
63 x 147	3.67	3.52	3.21	3.50	3.37	3.07	3.16	3.04	2.76
63 x 170	4.21	4.06	3.70	4.04	3.89	3.54	3.64	3.51	3.19
63 x 195	4.77	4.64	4.23	4.61	4.45	4.05	4.17	4.01	3.65
63 x 220	5.20	5.06	4.73	5.50	4.91	4.56	4.68	4.51	4.11
75 x 122	3.22	3.10	2.83	3.09	2.97	2.71	2.78	2.68	2.43
75 x 147	3.86	3.72	3.39	3.70	3.57	3.25	3.34	3.22	2.93
75 x 170	4.45	4.29	3.91	4.27	4.11	3.75	3.86	3.71	3.38
75 x 195	4.97	4.83	4.47	4.82	4.69	4.29	4.41	4.25	3.86
75 x 220	5.42	5.27	4.93	5.25	5.11	4.78	4.88	4.74	4.35
38 x 140	2.96	2.84	2.58	2.83	2.72	2.47	2.54	2.44	2.17
38 x 184	3.87	3.72	3.38	3.70	3.56	3.23	3.33	3.20	2.90
38 x 235	4.85	4.71	4.31	4.70	4.54	4.12	4.24	4.08	3.70

SC4

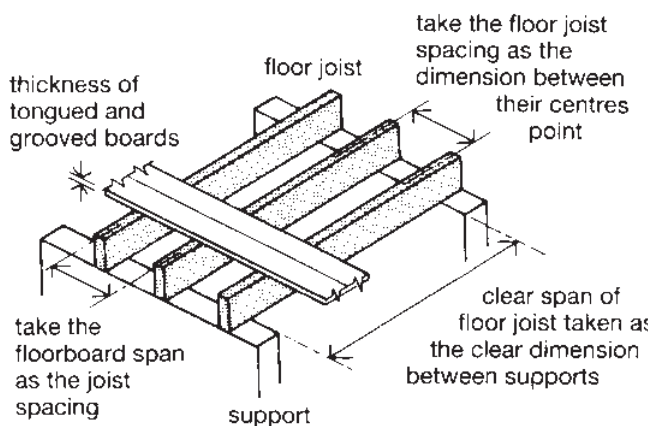

3 The section sizes are either regularised from BS 4471 basic sawn sizes in accordance with the requirements and tolerances of BS 4471 or CLS/AIS sizes with BS 4471 tolerances.

4 The minimum bearing length at supports for floor joists should be 35mm.

5 Notches and drilling of floor joists should not exceed the limits given in paragraph 1B6.

6 Partition loads have not been allowed for in Tables A1 and A2.

Table A3 Ceiling joists

Maximum clear span of joist (m) Timber of strength class SC3 and SC4 (see Table 1)

Size of joist (mm x mm)	Dead Load [kN/m ²] excluding the self weight of the joist											
	Not more than 0.25			More than 0.25 but not more than 0.50			Not more than 0.25			More than 0.25 but not more than 0.50		
	Spacing of joists (mm)											
	400	450	600	400	450	600	400	450	600	400	450	600
38 x 72	1.15	1.14	1.11	1.11	1.10	1.06	1.21	1.20	1.17	1.17	1.16	1.12
38 x 97	1.74	1.72	1.67	1.67	1.64	1.58	1.84	1.82	1.76	1.76	1.73	1.66
38 x 122	2.37	2.34	2.25	2.25	2.21	2.11	2.50	2.46	2.37	2.37	2.33	2.22
38 x 147	3.02	2.97	2.85	2.85	2.80	2.66	3.18	3.13	3.00	3.00	2.94	2.79
38 x 170	3.63	3.57	3.41	3.41	3.34	3.16	3.81	3.75	3.58	3.58	3.51	3.32
38 x 195	4.30	4.23	4.02	4.02	3.94	3.72	4.51	4.43	4.22	4.22	4.13	3.89
38 x 220	4.98	4.88	4.64	4.64	4.54	4.27	5.21	5.11	4.86	4.86	4.75	4.47
47 x 72	1.27	1.26	1.23	1.23	1.21	1.17	1.35	1.33	1.30	1.30	1.28	1.24
47 x 97	1.92	1.90	1.84	1.84	1.81	1.73	2.03	2.00	1.93	1.93	1.90	1.83
47 x 122	2.60	2.57	2.47	2.47	2.42	2.31	2.74	2.70	2.60	2.60	2.55	2.43
47 x 147	3.30	3.25	3.11	3.11	3.05	2.90	3.47	3.42	3.27	3.27	3.21	3.04
47 x 170	3.96	3.89	3.72	3.72	3.64	3.44	4.15	4.08	3.89	3.89	3.81	3.61
47 x 195	4.68	4.59	4.37	4.37	4.28	4.04	4.90	4.81	4.57	4.57	4.47	4.22
47 x 220	5.39	5.29	5.03	5.03	4.91	4.63	5.64	5.53	5.25	5.25	5.14	4.84
50 x 72	1.31	1.30	1.27	1.27	1.25	1.21	1.39	1.37	1.34	1.34	1.32	1.28
50 x 97	1.97	1.95	1.89	1.89	1.86	1.78	2.08	2.06	1.99	1.99	1.96	1.88
50 x 122	2.67	2.63	2.53	2.53	2.49	2.37	2.81	2.77	2.66	2.66	2.62	2.49
50 x 147	3.39	3.34	3.19	3.19	3.13	2.97	3.56	3.50	3.35	3.35	3.29	3.12
50 x 170	4.06	3.99	3.81	3.81	3.73	3.53	4.25	4.18	3.99	3.99	3.91	3.69
50 x 195	4.79	4.70	4.48	4.48	4.38	4.13	5.01	4.92	4.68	4.68	4.58	4.32
50 x 220	5.52	5.41	5.14	5.14	5.03	4.73	5.77	5.66	5.37	5.37	5.25	4.95
38 x 89	1.54	1.53	1.48	1.48	1.46	1.41	1.63	1.62	1.57	1.57	1.55	1.49
38 x 140	2.84	2.79	2.68	2.68	2.63	2.50	2.99	2.94	2.82	2.82	2.77	2.63
28 x 184	4.01	3.94	3.75	3.75	3.68	3.47	4.20	4.13	3.94	3.94	3.85	3.64

Notes to Tables A3 and A4

- Where spans for ceiling joists or binders are unequal the section sizes should be determined by the longer span.
- See paragraph 1A2 which gives guidance on the need for bracing roof structures.

3 The sizes, spacings and spans given will support the dead loads given in the table and a maximum imposed load of 0.25 kN/m² and a concentrated load of 0.9 kN acting together.

In calculating the ceiling joist sizes no account has been taken of trimming (e.g. around the flues) or other loads (e.g. water tanks).

- The section sizes for ceiling joists are either regularised from BS 4471 basic sawn sizes with the tolerances of BS 4471 or CLS/ALS sizes with BS 4471 tolerances.
- The section sizes for binders are either BS 4471 basic sawn sizes with the tolerances of BS 4471 or CLS/ALS sizes with BS 4971 tolerances.
- The minimum bearing length at supports for ceiling joists and binders should be 35mm.
- No notches or holes should be cut in binders unless checked by a competent person.

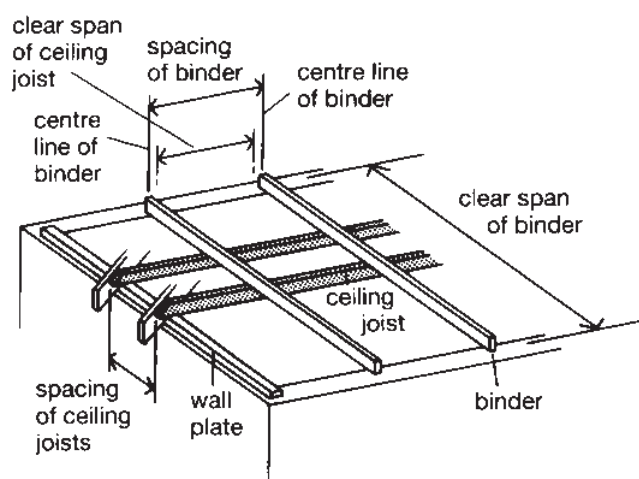

Table A4 Binders supporting ceiling joists

Maximum clear span of binder (m) Timber of strength class SC3 and SC4 (see Table 1)

Dead Load [kN/m²] excluding the self weight of the binder

Size of binder (mm x mm)	Not more than 0.25						More than 0.25 but not more than 0.50					
	Spacing of binders (mm)											
	1200	1500	1800	2100	2400	2700	1200	1500	1800	2100	2400	2700
47 x 150	2.17	2.05	1.96	1.88	1.81		1.99	1.87				
47 x 175	2.59	2.45	2.33	2.24	2.15	2.98	2.37	2.23	2.11	2.02	1.94	1.87
50 x 150	2.22	2.11	2.01	1.93	1.86		2.04	1.92	1.83			
50 x 175	2.65	2.51	2.39	2.29	2.21	2.13	2.42	2.28	2.16	2.07	1.99	1.91
50 x 200	3.08	2.91	2.77	2.65	2.55	2.47	2.81	2.64	2.50	2.39	2.29	2.21
63 x 125	1.97	1.87					1.82					
63 x 150	2.44	2.31	2.20	2.12	2.04	1.97	2.23	2.11	2.00	1.91	1.84	
63 x 175	2.90	2.74	2.61	2.51	2.41	2.33	2.65	2.49	2.37	2.26	2.17	2.10
63 x 200	3.37	3.18	3.03	2.90	2.79	2.69	3.07	2.88	2.74	2.61	2.51	2.42
63 x 225	3.83	3.61	3.44	3.29	3.16	3.05	3.49	3.27	3.10	2.96	2.84	2.74
75 x 125	2.12	2.01	1.92	1.85			1.95	1.84				
75 x 150	2.61	2.47	2.36	2.26	2.18	2.11	2.39	2.25	2.14	2.05	1.97	1.90
75 x 175	3.10	2.93	2.79	2.68	2.58	2.49	2.83	2.66	2.53	2.42	2.32	2.24
75 x 200	3.59	3.39	3.23	3.09	2.98	2.88	3.27	3.08	2.92	2.79	2.68	2.58
75 x 225	4.08	3.85	3.66	3.51	3.37	3.26	3.71	3.50	3.31	3.16	3.03	2.92
47 x 150	2.28	2.16	2.06	1.98	1.90	1.84	2.09	1.97	1.87			
47 x 175	2.27	2.57	2.45	2.34	2.26	2.18	2.48	2.34	2.22	2.12	2.03	1.96
50 x 150	2.33	2.21	2.11	2.02	1.95	1.89	2.14	2.02	1.92	1.83		
50 x 175	2.78	2.63	2.51	2.40	2.31	2.23	2.54	2.39	2.27	2.17	2.08	2.01
50 x 200	3.23	3.05	2.90	2.78	2.67	2.58	2.95	2.77	2.62	2.51	2.40	2.32
63 x 125	2.07	1.97	1.88	1.81			1.91	1.80				
63 x 150	2.56	2.42	2.31	2.22	2.14	2.07	2.34	2.21	2.10	2.01	1.93	1.86
63 x 175	3.04	2.87	2.74	2.62	2.53	2.44	2.78	2.61	2.48	2.37	2.28	2.20
63 x 200	3.52	3.32	3.16	3.03	2.92	2.82	3.21	3.02	2.86	2.73	2.63	2.53
63 x 225	4.00	3.77	3.59	3.44	3.31	3.19	3.65	3.42	3.24	3.10	2.97	2.86
75 x 125	2.22	2.11	2.01	1.94	1.87	1.81	2.04	1.93	1.84			
75 x 150	2.73	2.59	2.47	2.37	2.28	2.21	2.50	2.36	2.24	2.15	2.06	1.99
75 x 175	3.24	3.07	2.92	2.80	2.70	2.61	2.96	2.79	2.65	2.53	2.43	2.35
75 x 200	3.75	3.54	3.37	3.23	3.11	3.00	3.42	3.22	3.05	2.92	2.80	2.70
75 x 225	4.26	4.02	3.82	3.66	3.52	3.40	3.88	3.65	3.46	3.30	3.17	3.06

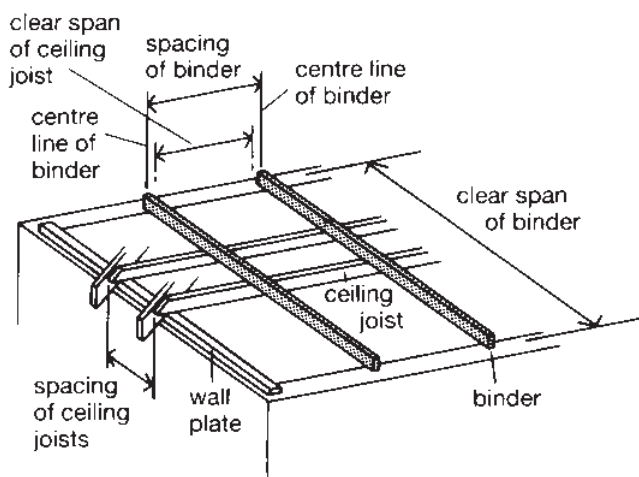
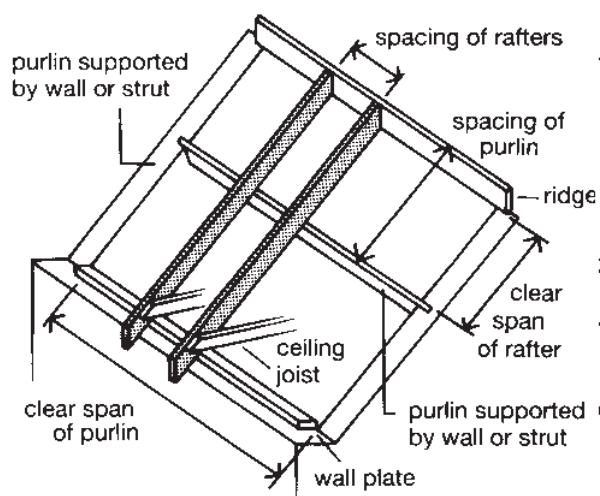

Table A5 Common or jack rafters for roofs having a pitch more than 15° but not more than 22.5° with access only for purposes of maintenance or repair. Imposed loading 0.75kN/m² (see Diagram 2)

Maximum clear span of rafter (m) Timber of strength class SC3 and SC4 (see Table 1)

Size of joist (mm x mm)	Dead Load [kN/m ²] excluding the self weight of the joist								
	Not more than 0.50			More than 0.50 but not more than 0.75			More than 0.75 but not more than 1.00		
	Spacing of rafters (mm)								
	400	450	600	400	450	600	400	450	600
38 x 100	2.10	2.05	1.93	1.93	1.88	1.75	1.80	1.75	1.61
38 x 125	2.89	2.79	2.53	2.63	2.55	2.34	2.44	2.35	2.15
38 x 150	3.47	3.34	3.03	3.26	3.14	2.78	3.08	2.96	2.57
47 x 100	2.46	2.40	2.18	2.25	2.19	2.03	2.10	2.03	1.87
47 x 125	3.10	2.99	2.72	2.92	2.81	2.56	2.78	2.67	2.41
47 x 150	3.71	3.57	3.25	3.50	3.36	3.06	3.32	3.20	2.86
50 x 100	2.54	2.45	2.23	2.35	2.29	2.09	2.19	2.12	1.95
50 x 125	3.17	3.05	2.78	2.98	2.87	2.61	2.83	2.73	2.48
50 x 150	3.78	3.64	3.32	3.57	3.43	3.12	3.39	3.26	2.94
38 x 89	1.76	1.72	1.63	1.63	1.59	1.49	1.53	1.49	1.38
38 x 140	3.24	3.12	2.83	3.05	2.93	2.61	2.82	2.72	2.41
38 x 100	2.42	2.33	2.11	2.28	2.19	1.99	2.16	2.08	1.88
38 x 125	3.01	2.90	2.64	2.83	2.73	2.48	2.69	2.59	2.35
38 x 150	3.60	3.47	3.16	3.39	3.26	2.97	3.22	3.10	2.82
47 x 100	2.59	2.49	2.27	2.44	2.35	2.13	2.32	2.23	2.02
47 x 125	3.22	3.11	2.83	3.04	2.92	2.66	2.89	2.78	2.53
47 x 150	3.85	3.71	3.38	3.63	3.50	3.18	3.45	3.32	3.02
50 x 100	2.64	2.54	2.32	2.49	2.40	2.18	2.37	2.28	2.07
50 x 125	3.29	3.17	2.89	3.10	2.98	2.72	2.95	2.83	2.58
50 x 150	3.93	3.78	3.45	3.70	3.57	3.25	3.52	3.39	3.09
38 x 89	2.16	2.07	1.88	2.03	1.95	1.77	1.92	1.85	1.68
38 x 140	3.37	3.24	2.95	3.17	3.05	2.77	3.01	2.90	2.63



take the clear span for the purlin as the clear dimension between supporting struts and/or walls

Notes to Tables A5 and A6

- 1 The sizes spacings and spans given will support the dead loads stated in the table and imposed loads of 0.75 kN/m², measured on plan or a concentrated load of 0.9 kN.
- 2 The tables are applicable to purlins installed perpendicular to the roof slope, whereby any horizontal thrust sustained by the rafters is restrained by the ceiling joists, or by other means.
- 3 When the spans of rafters or purlins are unequal the section sizes should be determined for each span or by the longest span.
- 4 The section sizes are either BS 4471 basic sawn sizes with the tolerances of BS 4471 or CLS/ALS sizes with BS 4471 tolerances.
- 5 No notches or holes should be cut in purlins unless checked by a competent person.
- 6 The minimum bearing length at supports should be 35mm for rafters and 50mm for purlins.

**Table A6 Purlins supporting rafters to which Table A5 refers
(Imposed loading 0.75 kN/m²)**

Maximum clear span of purlin(m) Timber of strength class SC3 and SC4 (see Table 1)

Size of purlin (mm x mm)	Dead Load [kN/m ²] excluding the self weight of the purlin																							
	Not more than 0.5						More than 0.5 but not more than 0.75						More than 0.75 but not more than 1.0											
	Spacing of purlins (mm)																							
	1500	1800	2100	2400	2700	3000	1500	1800	2100	2400	2700	3000	1500	1800	2100	2400	2700	3000						
50 x 150	1.90																							
50 x 175	2.22	2.08	1.96	1.87			2.08	1.95	1.84					1.97	1.84									
50 x 200	2.53	2.37	2.24	2.13	2.02	1.92	2.38	3.33	2.10	1.97	1.85			2.25	2.10	1.95	1.82							
50 x 225	2.84	2.66	2.52	2.40	2.26	2.14	2.67	2.50	2.35	2.20	2.07	1.96		2.53	2.36	2.18	2.03	1.91	1.81					
63 x 150	2.06	1.94	1.83				1.94	1.82						1.84										
63 x 175	2.41	2.26	2.13	2.03	1.95	1.87	2.26	2.12	2.00	1.91	1.82			2.14	2.01	1.90	1.80							
63 x 200	2.75	2.58	2.44	2.32	2.22	2.14	2.58	2.42	2.29	2.18	2.08	1.97		2.45	2.29	2.16	2.05	1.93	1.83					
63 x 225	3.09	2.89	2.74	2.61	2.50	2.40	2.90	2.72	2.57	2.45	2.33	2.20		2.75	2.58	2.43	2.29	2.16	2.04					
75 x 125	1.83																							
75 x 150	2.19	2.06	1.95	1.86			2.06	1.94	1.83					1.96	1.83									
75 x 175	2.56	2.40	2.27	2.17	2.08	2.00	2.41	2.26	2.13	2.03	1.95	1.87		2.28	2.14	2.02	1.92	1.84						
75 x 200	2.92	2.74	2.59	2.47	2.37	2.28	2.75	2.58	2.44	2.32	2.22	2.14		2.61	2.44	2.31	2.20	2.10	2.00					
75 x 225	3.28	3.08	2.91	2.78	2.66	2.56	3.09	2.89	2.74	2.61	2.50	2.40		2.93	2.74	2.60	2.47	2.36	2.23					
50 x 150	1.99	1.86					1.87																	
50 x 175	2.32	2.17	2.05	1.95	1.87		2.18	2.04	1.92	1.83				2.06	1.93	1.82								
50 x 200	2.64	2.48	2.34	2.23	2.14	2.05	2.49	2.33	2.20	2.09	2.00	1.92		2.36	2.20	2.08	1.98	1.89						
50 x 225	2.97	2.78	2.63	2.51	2.40	2.31	2.79	2.62	2.47	2.35	2.25	2.16		2.65	2.48	2.34	2.22	2.12	1.94					
63 x 150	2.16	2.02	1.91	1.82			2.03	1.90						1.92	1.80									
63 x 175	2.51	2.36	2.23	2.13	2.04	1.96	2.36	2.22	2.10	2.00	1.91	1.84		2.24	2.10	1.99	1.89	1.81						
63 x 200	2.87	2.69	2.55	2.43	2.33	2.24	2.70	2.53	2.39	2.28	2.18	2.10		2.56	2.40	2.27	2.16	2.06	1.98					
63 x 225	3.22	3.02	2.86	2.73	2.61	2.52	3.03	2.84	2.69	2.56	2.45	2.36		2.88	2.70	2.55	2.43	2.32	2.23					
75 x 125	1.91																							
75 x 150	2.29	2.15	1.04	1.94	1.86		2.16	2.02	1.91	1.82				2.05	1.92	1.82								
75 x 175	2.67	2.51	2.37	2.26	2.17	2.09	2.51	2.36	2.23	2.13	2.04	1.96		2.39	2.24	2.12	2.02	1.93	1.85					
75 x 200	3.05	2.86	2.71	2.58	2.48	2.39	2.87	2.69	2.55	2.43	2.33	2.24		2.72	2.55	2.42	2.30	2.20	2.12					
75 x 225	3.42	3.21	3.04	2.90	2.78	2.68	3.22	3.02	2.86	2.73	2.62	2.52		3.06	2.87	2.72	2.59	2.48	2.38					

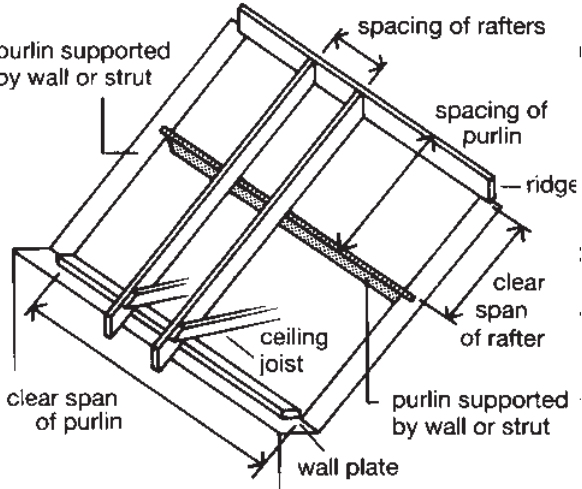

take the clear span for the purlin as the clear dimension between supporting struts and/or walls

Table A7 Common or jack rafters for roofs having a pitch more than 22.5° but not more than 30° with access only for purposes of maintenance or repair. Imposed loading 0.75 kN/m²

Maximum clear span of rafter(m) Timber of strength class SC3 and SC4 (see Table 1)

Size of rafter (mm x mm)	Dead Load [kN/m ²] excluding the self weight of the rafter								
	Not more than 0.50			More than 0.50 but not more than 0.75			More than 0.75 but not more than 1.00		
	Spacing of rafters (mm)								
	400	450	600	400	450	600	400	450	600
38 x 100	2.18	2.13	2.01	2.01	1.96	1.82	1.88	1.82	1.68
38 x 125	2.97	2.86	2.60	2.74	2.66	2.44	2.54	2.46	2.25
38 x 150	3.55	3.42	3.11	3.34	3.21	2.92	3.17	3.04	2.72
47 x 100	2.55	2.46	2.23	2.35	2.28	2.10	2.18	2.12	1.95
47 x 125	3.18	3.06	2.79	2.99	2.88	2.62	2.84	2.73	2.48
47 x 150	3.80	3.66	3.33	3.57	3.44	3.13	3.39	3.27	2.97
50 x 100	2.60	2.51	2.28	2.45	2.36	2.14	2.28	2.21	2.03
50 x 125	3.24	3.12	2.84	3.05	2.93	2.67	2.89	2.79	2.53
50 x 150	3.87	3.73	3.40	3.65	3.51	3.20	3.46	3.33	3.03
38 x 89	1.82	1.79	1.69	1.69	1.65	1.55	1.59	1.55	1.44
38 x 140	3.32	3.19	2.90	3.12	3.00	2.72	2.94	2.84	2.55
38 x 100	2.48	2.38	2.17	2.33	2.24	2.03	2.21	2.12	1.93
38 x 125	3.08	2.97	2.70	2.90	2.79	2.53	2.75	2.65	2.40
38 x 150	3.69	3.55	3.23	3.47	3.34	3.04	3.29	3.17	2.88
47 x 100	2.65	2.55	2.32	2.49	2.40	2.18	2.37	2.28	2.07
47 x 125	3.30	3.18	2.90	3.11	2.99	2.72	2.95	2.84	2.58
47 x 150	3.94	3.80	3.46	3.71	3.58	3.26	3.53	3.40	3.09
50 x 100	2.71	2.61	2.37	2.55	2.45	2.23	2.42	2.32	2.11
50 x 125	3.37	3.24	2.96	3.17	3.05	2.78	3.01	2.90	2.63
50 x 150	4.02	3.87	3.53	3.79	3.65	3.32	3.60	3.46	3.15
38 x 89	2.21	2.12	1.93	2.07	1.99	1.81	1.97	1.89	1.72
38 x 140	3.45	3.32	3.02	3.24	3.12	2.84	3.08	2.96	2.69

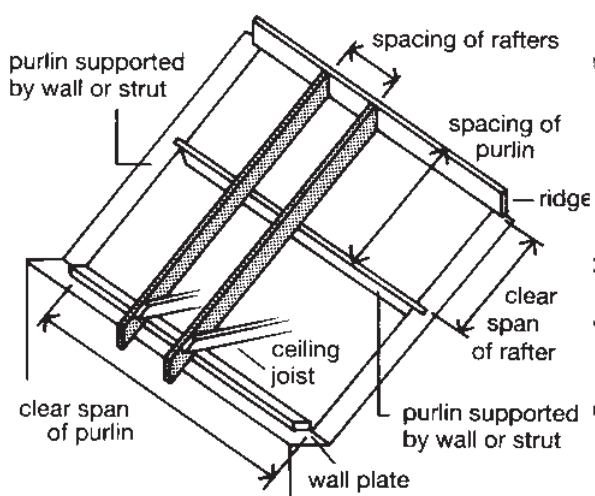

take the clear span for the purlin as the clear dimension between supporting struts and/or walls

Notes to Tables A7 and A8

- 1 The sizes spacings and spans given will support the dead loads stated in the table and imposed loads of 1.00 kN/m², measured on plan or a concentrated load of 0.9 kN.
- 2 The tables are applicable to purlins installed perpendicular to the roof slope, whereby any horizontal thrust sustained by the rafters is restrained by the ceiling joists, or by other means.
- 3 When the spans of rafters or purlins are unequal the section sizes should be determined for each span or by the longest span.
- 4 The section sizes are either BS 4471 basic sawn sizes with the tolerances of BS 4471 or CLS/ALS sizes with BS 4471 tolerances.
- 5 No notches or holes should be cut in purlins unless checked by a competent person.
- 6 The minimum bearing length at supports should be 35mm for rafters and 50mm for purlins.

**Table A8 Purlins supporting rafters to which Table A7 refers
(Imposed loading 0.75 kN/m²)**

Maximum clear span of purlin(m) Timber of strength class SC3 and SC4 (see Table 1)

Size of purlin (mm x mm)	Dead Load [kN/m ²] excluding the self weight of the purlin																	
	Not more than 0.5						More than 0.50 but not more than 0.75						More than 0.75 but not more than 1.00					
	Spacing of purlins (mm)																	
	1500	1800	2100	2400	2700	3000	1500	1800	2100	2400	2700	3000	1500	1800	2100	2400	2700	3000
50 x 150	1.95	1.83					1.83											
50 x 175	2.27	2.12	2.01	1.92	1.83		2.13	1.99	1.88				2.02	1.89				
50 x 200	2.59	2.43	2.30	2.19	2.09	1.99	2.43	2.28	2.15	2.03	1.91	1.81	2.30	2.15	2.01	1.88		
50 x 225	2.92	2.73	2.58	2.46	2.34	2.22	2.74	2.56	2.42	2.27	2.14	2.02	2.59	2.42	2.25	2.10	1.98	1.87
63 x 150	2.12	1.98	1.88				1.99	1.86					1.88					
63 x 175	2.47	2.31	2.19	2.09	2.00	1.92	2.32	2.17	2.05	1.95	1.87		2.19	2.05	1.94	1.85		
63 x 200	2.81	2.64	2.50	2.38	2.28	2.19	2.64	2.48	2.34	2.23	2.13	2.04	2.50	2.35	2.22	2.11	1.99	1.89
63 x 225	3.16	2.97	2.81	2.68	2.56	2.47	2.97	2.78	2.63	2.51	2.30	2.28	2.82	2.64	2.49	2.37	2.23	2.11
75 x 125	1.88																	
75 x 150	2.25	2.11	2.00	1.91	1.83		2.11	1.98	1.87				2.00	1.88				
75 x 175	2.62	2.46	2.33	2.22	2.13	2.05	2.46	2.31	2.19	2.08	1.99	1.92	2.33	2.19	2.07	1.97	1.89	1.81
75 x 200	2.99	2.81	2.66	2.54	2.43	2.34	2.81	2.64	2.50	2.38	2.28	2.19	2.67	2.50	2.36	2.25	2.15	2.07
75 x 225	3.36	3.15	2.99	2.85	2.73	2.63	3.16	2.96	2.80	2.67	2.56	2.46	3.00	2.81	2.66	2.53	2.42	2.31
50 x 150	2.04	1.91	1.81				1.91						1.31					
50 x 175	2.37	2.22	2.10	2.00	1.92	1.84	2.23	2.09	1.97	1.88			2.11	1.97	1.86			
50 x 200	2.71	2.54	2.40	2.29	2.19	2.11	2.54	2.38	2.25	2.14	2.05	1.97	2.41	2.26	2.13	2.02	1.94	1.84
50 x 225	3.05	2.86	2.70	2.57	2.46	2.37	2.86	2.68	2.53	2.41	2.30	2.21	2.71	2.54	2.39	2.28	2.18	2.07
63 x 125	1.84																	
63 x 150	2.21	2.07	1.96	1.87			2.08	1.95	1.84				1.97	1.84				
63 x 175	2.57	2.42	2.29	2.18	2.09	2.01	2.42	2.27	2.15	2.04	1.96	1.88	2.29	2.15	2.03	1.93	1.85	
63 x 200	2.94	2.76	2.61	2.49	2.39	2.30	2.76	2.59	2.45	2.33	2.24	2.15	2.62	2.45	2.32	2.21	2.11	2.03
63 x 225	3.30	3.10	2.93	2.80	2.68	2.58	3.10	2.91	2.75	2.62	2.51	2.42	2.94	2.76	2.61	2.48	2.38	2.28
75 x 125	1.96	1.84					1.84											
75 x 150	2.35	2.20	2.09	1.99	1.91	1.84	2.21	2.07	1.96	1.87			2.09	1.96	1.86			
75 x 175	2.73	2.57	2.43	2.32	2.22	2.14	2.57	2.41	2.28	2.18	2.09	2.01	2.44	2.29	2.16	2.06	1.97	1.90
75 x 200	3.12	2.93	2.78	2.65	2.54	2.45	2.93	2.75	2.61	2.49	2.38	2.29	2.79	2.61	2.47	2.35	2.26	2.17
75 x 225	3.50	3.29	3.12	2.98	2.86	2.75	3.30	3.10	2.93	2.80	2.68	2.58	3.13	2.94	2.78	2.65	2.54	2.44

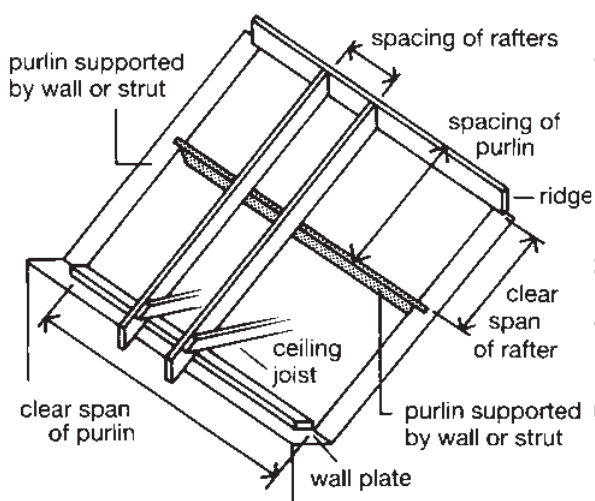

take the clear span for the purlin as the clear dimension between supporting struts and/or walls

Table A9 Common or jack rafters for roofs having a pitch more than 30° but not more than 45° with access only for purposes of maintenance or repair. Imposed loading 0.75 kN/m²

Maximum clear span of rafter(m) Timber of strength class SC3 and SC4 (see Table 1)

Size of rafter (mm x mm)	Dead Load [kN/m ²] excluding the self weight of the rafter								
	Not more than 0.50			More than 0.50 but not more than 0.75			More than 0.75 but not more than 1.25		
	Spacing of rafters (mm)								
	400	450	600	400	450	600	400	450	600
38 x 100	2.28	2.23	2.10	2.10	2.05	1.91	1.96	1.91	1.76
38 x 125	3.07	2.95	2.69	2.87	2.77	2.52	2.65	2.56	2.35
38 x 150	3.67	3.53	3.22	3.44	3.31	3.01	3.26	3.14	2.85
47 x 100	2.64	2.54	2.31	2.45	2.38	2.17	2.28	2.21	2.04
47 x 125	3.29	3.17	2.88	3.09	3.07	2.70	2.92	2.81	2.56
47 x 150	3.93	3.78	3.45	3.69	3.55	3.23	3.50	3.37	3.06
50 x 100	2.69	2.59	2.36	2.53	2.43	2.21	2.38	2.30	2.09
50 x 125	3.35	3.23	2.94	3.15	3.03	2.76	2.98	2.87	2.61
50 x 150	4.00	3.86	3.52	3.76	3.62	3.30	3.57	3.44	3.13
38 x 89	1.91	1.87	1.77	1.77	1.73	1.62	1.67	1.62	1.50
38 x 140	3.43	3.30	3.01	3.22	3.10	2.82	3.05	2.93	2.66
38 x 100	2.56	2.47	2.24	2.40	2.31	2.10	2.28	2.19	1.99
38 x 125	3.19	3.07	2.80	2.99	2.88	2.62	2.84	2.73	2.48
38 x 150	3.81	3.67	3.35	3.58	3.45	3.14	3.39	3.27	2.97
47 x 100	2.74	2.64	2.41	2.58	2.48	2.25	2.44	2.35	2.13
47 x 125	3.41	3.29	3.00	3.21	3.09	2.81	3.04	2.93	2.66
47 x 150	4.08	3.93	3.59	3.83	3.69	3.36	3.64	3.50	3.19
50 x 100	2.80	2.70	2.45	2.63	2.53	2.30	2.49	2.40	2.18
50 x 125	3.48	3.35	3.06	3.27	3.15	2.87	3.10	2.99	2.72
50 x 150	4.16	4.01	3.66	3.91	3.77	3.43	3.71	3.57	3.25
38 x 89	2.28	2.20	2.00	2.14	2.06	1.87	2.03	1.95	1.77
38 x 140	3.56	3.43	3.13	3.35	3.22	2.93	3.17	3.05	2.77

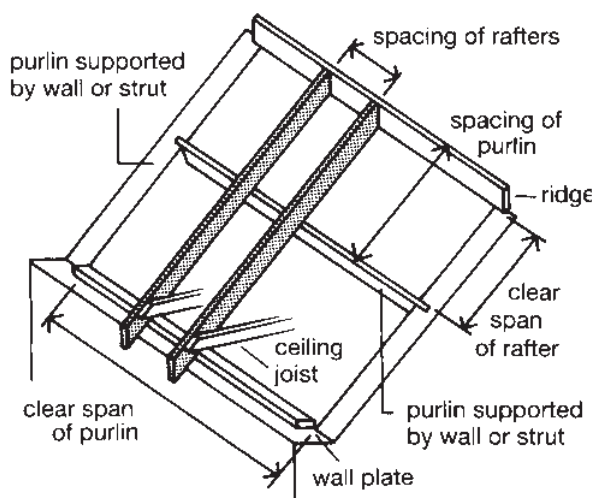

take the clear span for the purlin as the clear dimension between supporting struts and/or walls

Notes to Tables A9 and A10

- 1 The sizes spacings and spans given will support the dead loads stated in the table and imposed loads of 0.75 kN/m², measured on plan or a concentrated load of 0.9 kN.
- 2 The tables are applicable to purlins installed perpendicular to the roof slope, whereby any horizontal thrust sustained by the rafters is restrained by the ceiling joists, or by other means.
- 3 When the spans of rafters or purlins are unequal the section sizes should be determined for each span or by the longest span.
- 4 The section sizes are either BS 4471 basic sawn sizes with the tolerances of BS 4471 or CLS/ALS sizes with BS 4471 tolerances.
- 5 No notches or holes should be cut in purlins unless checked by a competent person.
- 6 The minimum bearing length at supports should be 35mm for rafters and 50mm for purlins.

**Table A10 Purlins supporting rafters to which Table A9 refers
(Imposed loading 0.75 kN/m²)**

Maximum clear span of purlin(m) Timber of strength class SC3 and SC4 (see Table 1)

Size of purlin (mm x mm)	Dead Load [kN/m ²] excluding the self weight of the purlin																	
	Not more than 0.50						More than 0.50 but not more than 0.75						More than 0.75 but not more than 1.00					
	Spacing of purlins (mm)																	
	1500	1800	2100	2400	2700	3000	1500	1800	2100	2400	2700	3000	1500	1800	2100	2400	2700	3000
50 x 150	2.02	1.89					1.89											
50 x 175	2.36	2.21	2.09	1.99	1.90	1.83	2.21	2.06	1.95	1.86			2.08	1.95	1.84			
50 x 200	2.69	2.52	2.38	2.27	2.17	2.09	2.52	2.36	2.23	2.12	2.01	1.90	2.38	2.23	2.10	1.97	1.85	
50 x 225	3.02	2.83	2.68	2.55	2.44	2.34	2.83	2.65	2.50	2.38	2.24	2.12	2.68	2.50	2.36	2.20	2.07	1.96
63 x 125	1.83																	
63 x 150	2.19	2.06	1.95	1.85			2.05	1.93	1.82				1.94	1.82				
63 x 175	2.55	2.40	2.27	2.16	2.07	1.99	2.39	2.24	2.12	2.02	1.94	1.86	2.27	2.12	2.01	1.91	1.83	
63 x 200	2.91	2.74	2.59	2.47	2.37	2.28	2.73	2.56	2.42	2.31	2.21	2.13	2.59	2.42	2.29	2.18	2.09	1.98
63 x 225	3.28	3.07	2.91	2.78	2.66	2.56	3.07	2.88	2.73	2.60	2.49	2.39	2.91	2.72	2.58	2.45	2.33	2.21
75 x 125	1.94	1.82					1.82											
75 x 150	2.33	2.19	2.07	1.97	1.89	1.82	2.18	2.05	1.94	1.85			2.07	1.94	1.83			
75 x 175	2.71	2.55	2.41	2.30	2.21	2.12	2.55	2.39	2.26	2.15	2.06	1.99	2.41	2.26	2.14	2.04	1.95	1.87
75 x 200	3.10	2.91	2.75	2.63	2.52	2.43	2.91	2.73	2.58	2.46	2.36	2.27	2.75	2.58	2.44	2.33	2.23	2.14
75 x 225	3.48	3.27	3.10	2.95	2.83	2.73	3.26	3.06	2.90	2.77	2.65	2.55	3.09	2.90	2.74	2.61	2.50	2.41
50 x 150	2.11	1.98	1.87				1.98	1.85					1.87					
50 x 175	2.46	2.31	2.18	2.08	1.99	1.91	2.31	2.16	2.04	1.94	1.86		2.18	2.04	1.93	1.83		
50 x 200	2.81	2.63	2.49	2.37	2.27	2.19	2.63	2.47	2.33	2.22	2.12	2.04	2.49	2.33	2.20	2.09	2.00	1.92
50 x 225	3.16	2.96	2.80	2.67	2.56	2.46	2.96	2.77	2.62	2.50	2.39	2.30	2.80	2.62	2.48	2.36	2.25	2.16
63 x 125	1.91																	
63 x 150	2.29	2.15	2.03	1.94	1.86		2.15	2.01	1.90	1.81			2.03	1.90	1.80			
63 x 175	2.67	2.50	2.37	2.26	2.17	2.08	2.50	2.35	2.22	2.12	2.03	1.95	2.37	2.22	2.10	2.00	1.91	1.84
63 x 200	3.04	2.86	2.71	2.58	2.47	2.38	2.86	2.68	2.54	2.42	2.31	2.23	2.70	2.53	2.40	2.28	2.19	2.10
63 x 225	3.42	3.21	3.04	2.90	2.78	2.68	3.21	3.01	2.85	2.72	2.60	2.50	3.04	2.85	2.70	2.57	2.55	2.36
75 x 125	2.03	1.90	1.80				1.90						1.80					
75 x 150	2.43	2.28	2.16	2.06	1.98	1.91	2.28	2.14	2.03	1.93	1.85		2.16	2.03	1.92	1.83		
75 x 175	2.83	2.66	2.52	2.40	2.31	2.22	2.66	2.49	2.36	2.25	2.16	2.08	2.52	2.36	2.24	2.13	2.04	1.96
75 x 200	3.23	3.03	2.88	2.74	2.63	2.54	3.03	2.85	2.70	2.57	2.47	2.37	2.88	2.70	2.55	2.43	2.33	2.24
75 x 225	3.63	3.41	3.23	3.08	2.96	2.85	3.41	3.20	3.03	2.89	2.77	2.67	3.23	3.03	2.87	2.74	2.62	2.52

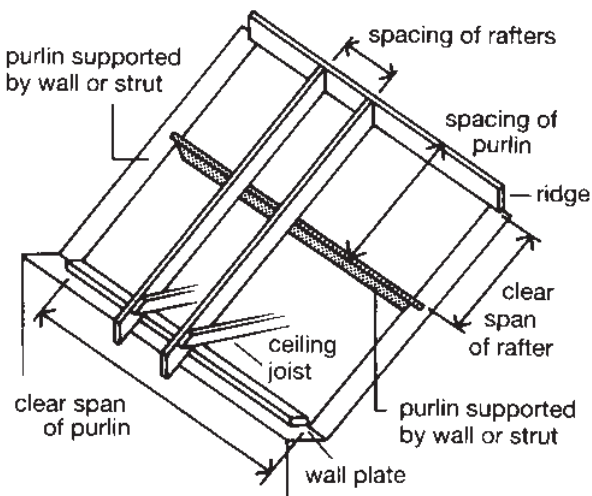

take the clear span for the purlin as the clear dimension between supporting struts and/or walls

Table A11 Joists for flat roofs with access only for purposes of maintenance or repair. (Imposed loading 0.75 kN/m²)

Maximum clear span of joist(m) Timber of strength class SC3 (see Table 1)

Size of joist (mm x mm)	Dead Load [kN/m ²] excluding the self weight of the joist								
	Not more than 0.50			More than 0.50 but not more than 0.75			More than 0.75 but not more than 1.00		
	Spacing of joists (mm)								
	400	450	600	400	450	600	400	450	600
38 x 97	1.74	1.72	1.67	1.67	1.64	1.58	1.61	1.58	1.51
38 x 122	2.37	2.34	2.25	2.25	2.21	2.11	2.16	2.11	2.01
38 x 147	3.02	2.97	2.85	2.85	2.80	2.66	2.72	2.66	2.51
38 x 170	3.63	3.57	3.37	3.41	3.34	3.17	3.24	3.17	2.98
38 x 195	4.30	4.23	3.86	4.03	3.94	3.63	3.81	3.72	3.45
38 x 220	4.94	4.76	4.34	4.64	4.49	4.09	4.38	4.27	3.88
47 x 97	1.92	1.90	1.84	1.84	1.81	1.74	1.77	1.74	1.65
47 x 122	2.60	2.57	2.47	2.47	2.43	2.31	2.36	2.31	2.19
47 x 147	3.30	3.25	3.12	3.12	3.06	2.90	2.96	2.90	2.74
47 x 170	3.96	3.89	3.61	3.72	3.64	3.40	3.53	3.44	3.23
47 x 195	4.68	4.53	4.13	4.37	4.28	3.89	4.14	4.40	3.70
47 x 220	5.28	5.09	4.65	4.99	4.81	4.38	4.75	4.58	4.17
50 x 97	1.97	1.95	1.89	1.89	1.86	1.78	1.81	1.78	1.70
50 x 122	2.67	2.64	2.53	2.53	2.49	2.37	2.42	2.37	2.25
50 x 147	3.39	3.34	3.19	3.19	3.13	2.97	3.04	2.97	2.80
50 x 170	4.06	3.99	3.69	3.81	3.73	3.47	3.61	3.53	3.30
50 x 195	4.79	4.62	4.22	4.48	4.36	3.97	4.23	4.13	3.78
50 x 220	5.38	5.19	4.74	5.09	4.90	4.47	4.85	4.67	4.25
63 x 97	2.19	2.16	2.09	2.09	2.06	1.97	2.01	1.97	1.87
63 x 122	2.95	2.91	2.79	2.79	2.74	2.61	2.66	2.61	2.47
63 x 147	3.72	3.66	3.44	3.50	3.43	3.25	3.33	3.26	3.07
63 x 170	4.44	4.35	3.97	4.16	4.07	3.74	3.95	3.85	3.56
63 x 195	5.14	4.96	4.54	4.86	4.69	4.28	4.61	4.47	4.07
63 x 220	5.77	5.57	5.10	5.46	5.27	4.82	5.21	5.02	4.59
75 x 122	3.17	3.12	3.00	3.00	2.94	2.80	2.86	2.80	2.65
75 x 147	3.98	3.92	3.64	3.75	3.67	3.44	3.56	3.48	3.27
75 x 170	4.74	4.58	4.19	4.44	4.33	3.96	4.21	4.11	3.77
75 x 195	5.42	5.23	4.79	5.13	4.95	4.53	4.89	4.72	4.31
75 x 220	6.07	5.87	5.38	5.76	5.56	5.09	5.50	5.30	4.85
38 x 140	2.84	2.79	2.68	2.68	2.63	2.51	2.56	2.51	2.37
38 x 184	4.01	3.94	3.64	3.76	3.68	3.43	3.56	3.48	3.25

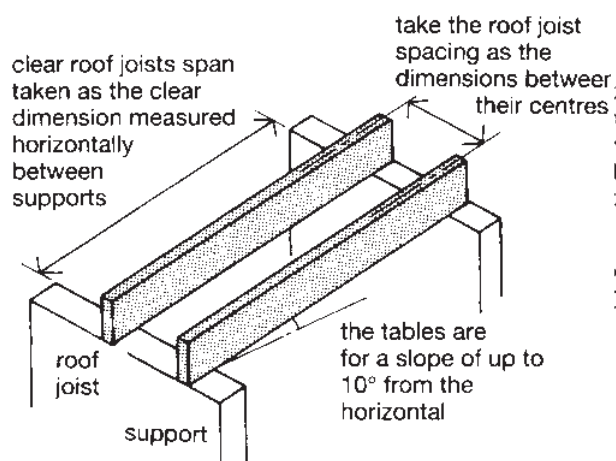

Notes

- 1 The sizes spacings and spans given will support the dead loads stated in the table and imposed loads of 0.75 kN/m², or a concentrated load of 0.9 kN.
- 2 The section sizes are either BS 4471 basic sawn sizes with the tolerances of BS 4471 or CLS/ALS sizes with BS 4471 tolerances.
- 3 The minimum bearing length at supports for roof joists should be 35mm.
- 4 Notches and drilling of roof joists should not exceed the limit given in paragraph 1B6.

Table A12 Joists for flat roofs with access only for purposes of maintenance or repair. Imposed loading 0.75 kN/m²

Maximum clear span of joist(m) Timber of strength class SC4 (see Table 1)

Size of joist (mm x mm)	Dead Load [kN/m ²] excluding the self weight of the joist								
	Not more than 0.50			More than 0.50 but not more than 0.75			More than 0.75 but not more than 1.00		
	Spacing of joists (mm)								
	400	450	600	400	450	600	400	450	600
38 x 97	1.84	1.82	1.76	1.76	1.73	1.66	1.69	1.66	1.59
38 x 122	2.50	2.46	2.37	2.37	2.33	2.22	2.27	2.22	2.11
38 x 147	3.18	3.13	3.00	3.00	2.94	2.79	2.85	2.79	2.64
38 x 170	3.81	3.75	3.50	3.58	3.51	3.30	3.40	3.32	3.12
38 x 195	4.51	4.40	4.01	4.22	4.13	3.78	3.99	3.90	3.59
38 x 220	5.13	4.95	4.51	4.85	4.67	4.25	4.59	4.44	4.04
47 x 97	2.03	2.00	1.94	1.94	1.91	1.83	1.86	1.83	1.74
47 x 122	2.74	2.70	2.60	2.60	2.55	2.43	2.48	2.43	2.30
47 x 147	3.47	3.42	3.26	3.27	3.21	3.04	3.11	3.04	2.87
47 x 170	4.15	4.08	3.76	3.89	3.81	3.54	3.69	3.61	3.36
47 x 195	4.88	4.70	4.29	4.58	4.44	4.05	4.33	4.22	3.85
47 x 220	5.48	5.29	4.83	5.18	5.00	4.56	4.94	4.76	4.33
50 x 97	2.08	2.06	1.99	1.99	1.96	1.88	1.91	1.88	1.79
50 x 122	2.81	2.77	2.66	2.66	2.62	2.49	2.54	2.49	2.36
50 x 147	3.56	3.50	3.32	3.35	3.29	3.12	3.19	3.12	2.94
50 x 170	4.26	4.18	3.83	3.99	3.91	3.61	3.78	3.69	3.43
50 x 915	4.97	4.80	4.38	4.68	4.53	4.13	4.43	4.31	3.39
50 x 220	5.59	5.39	4.93	5.28	5.09	4.65	5.04	4.85	4.42
63 x 97	2.31	2.28	2.20	2.20	2.16	2.07	2.11	2.07	1.97
63 x 122	3.10	3.05	2.93	2.93	2.88	2.74	2.80	2.74	2.59
63 x 147	3.90	3.84	3.58	3.67	3.60	3.38	3.49	3.41	3.21
63 x 170	4.65	4.51	4.12	4.35	4.26	3.89	4.13	4.03	3.70
63 x 195	5.33	5.15	4.71	5.05	4.87	4.45	4.82	4.64	4.24
63 x 220	5.98	5.78	5.30	5.56	5.47	5.00	5.41	5.22	4.76
75 x 122	3.33	3.27	3.14	3.14	3.08	2.93	2.99	2.93	2.77
75 x 147	4.17	4.10	3.78	3.92	3.84	3.57	3.73	3.64	3.40
75 x 170	4.92	4.75	4.35	4.63	4.50	4.11	4.40	4.29	3.92
75 x 195	5.61	5.42	4.97	5.32	5.14	4.70	5.08	4.90	4.48
75 x 220	6.29	6.08	5.59	5.97	5.77	5.28	5.70	5.50	5.04
38 x 140	2.99	2.94	2.82	2.82	2.75	2.63	2.69	2.63	2.49
38 x 164	4.21	4.13	3.79	3.94	3.85	3.57	3.73	3.64	3.39

SC4

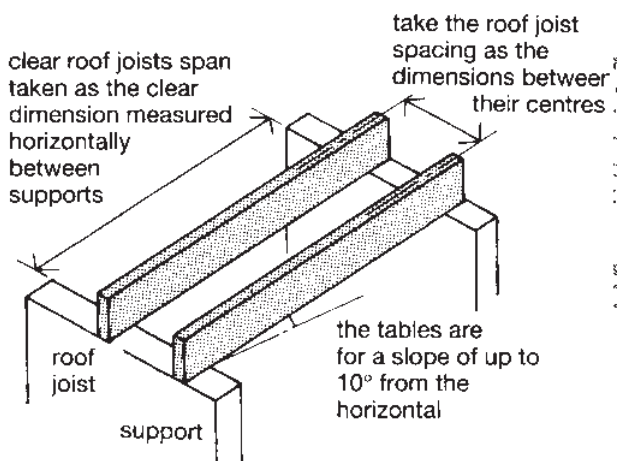

Notes

- 1 The sizes spacings and spans given will support the dead loads stated in the table and imposed loads of 0.75 kN/m², or a concentrated load of 0.9 kN.
- 2 The section sizes are either BS 4471 basic sawn sizes with the tolerances of BS 4471 or CLS.ALS sizes with BS 4471 tolerances.
- 3 The minimum bearing length at supports for roof joists should be 35mm.
- 4 Notches and drilling of roof joists should not exceed the limit given in paragraph 1B6.

Table A13 Joists for flat roofs with access not limited to the purposes of maintenance or repair. Imposed loading 0.75 kN/m²

Maximum clear span of joist(m) Timber of strength class SC3 (see Table 1)

Size of joist (mm x mm)	Dead Load [kN/m ²] excluding the self weight of the joist								
	Not more than 0.50			More than 0.50 but not more than 0.75			More than 0.75 but not more than 1.00		
	Spacing of joists (mm)								
	400	450	600	400	450	600	400	450	600
38 x 122	1.80	1.79	1.74	1.74	1.71	1.65	1.68	1.765	1.57
38 x 147	2.35	2.33	2.27	2.27	2.25	2.18	2.21	2.18	2.09
38 x 170	2.88	2.85	2.77	2.77	2.74	2.64	2.68	2.64	2.53
38 x 195	3.47	3.43	3.29	3.33	3.28	3.16	3.21	3.16	3.02
38 x 220	4.08	4.03	3.71	3.90	3.84	3.56	3.75	3.68	3.43
47 x 122	2.00	2.99	1.94	1.94	1.93	1.87	1.89	1.87	1.81
47 x 147	2.60	2.58	2.51	2.51	2.48	2.40	2.44	2.40	2.31
47 x 170	3.18	3.14	3.06	3.06	3.02	2.91	2.95	2.91	2.78
47 x 195	3.82	3.78	3.54	3.66	3.61	3.40	3.52	3.46	3.28
47 x 220	4.48	4.38	3.99	4.27	4.20	3.83	4.10	4.03	3.70
50 x 122	2.06	2.05	2.00	2.00	1.98	1.93	1.95	1.93	1.86
50 x 147	2.68	2.65	2.59	2.59	2.56	2.47	2.51	2.47	2.38
50 x 170	3.27	3.23	3.14	3.14	3.10	2.99	3.04	2.99	2.86
50 x 915	3.93	3.88	3.61	3.76	3.70	3.47	3.62	3.56	3.35
50 x 220	4.60	4.47	4.07	4.38	4.30	3.91	4.21	4.13	3.78
63 x 97	1.67	1.66	1.63	1.63	1.61	1.57	1.59	1.57	1.53
63 x 122	2.31	2.29	2.24	2.24	2.21	2.15	2.17	2.15	2.07
63 x 147	2.98	2.95	2.87	2.87	2.84	2.74	2.78	2.74	2.63
63 x 170	3.62	3.59	3.41	3.48	3.43	3.28	3.36	3.30	3.16
63 x 195	4.34	4.29	3.90	4.15	4.08	3.75	3.99	3.92	3.62
63 x 220	5.00	4.82	4.39	4.82	4.64	4.22	4.62	4.48	4.08
75 x 122	2.50	2.48	2.42	2.42	2.40	2.32	2.35	2.32	2.24
75 x 147	3.23	3.19	3.11	3.11	3.07	2.96	3.00	2.96	2.84
75 x 170	3.91	3.87	3.61	3.75	3.69	3.47	3.61	3.55	3.35
75 x 195	4.66	4.53	4.13	4.45	4.36	3.97	4.28	4.20	3.84
75 x 220	5.28	5.09	4.65	5.09	4.90	4.47	4.92	4.74	4.32
38 x 140	2.19	2.17	2.12	2.12	2.10	2.04	2.07	2.04	1.94
38 x 184	3.21	3.17	3.08	3.08	3.04	2.93	2.98	2.93	2.80

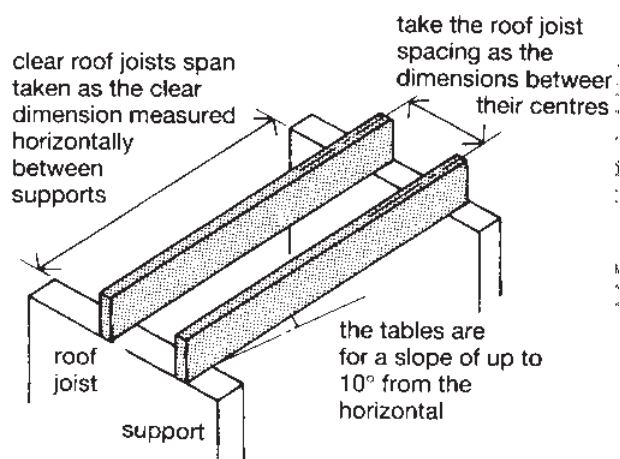

Notes

- 1 The sizes spacings and spans given will support the dead loads stated in the table and imposed loads of 1.50 kN/m², or a concentrated load of 0.9 kN.
- 2 The section sizes are either regularised from BS 4471 basic sawn sizes in accordance with the requirements and tolerances of BS 4471 or CLS/ALS sizes with BS 4471 tolerances.
- 3 The minimum bearing length at supports for roof joists should be 35mm.
- 4 Notches and drilling of roof joists should not exceed the limit given in paragraph 1B6.

Table A14 Joists for flat roofs with access not limited to the purposes of maintenance or repair. Imposed loading 0.75 kN/m²

Maximum clear span of joist(m) Timber of strength class SC4 (see Table 1)

Size of joist (mm x mm)	Dead Load [kN/m ²] excluding the self weight of the joist								
	Not more than 0.50			More than 0.50 but not more than 0.75			More than 0.75 but not more than 1.00		
	Spacing of joists (mm)								
	400	450	600	400	450	600	400	450	600
38 x 122	1.91	1.90	1.86	1.86	1.84	1.79	1.81	1.79	1.73
38 x 147	2.49	2.46	2.40	2.40	2.38	2.30	2.33	2.30	2.21
38 x 170	3.04	3.01	2.93	2.93	2.89	2.79	2.83	2.79	2.67
38 x 195	3.66	3.62	3.43	3.51	3.46	3.29	3.38	3.33	3.18
38 x 220	4.30	4.25	3.86	4.10	4.04	3.71	3.94	3.87	3.58
47 x 122	2.12	2.10	2.06	2.06	2.04	1.98	2.00	1.98	1.91
47 x 147	2.75	2.73	2.66	2.66	2.62	2.54	2.57	2.54	2.44
47 x 170	3.35	3.32	3.22	3.22	3.18	3.06	3.11	3.06	2.93
47 x 195	4.03	3.98	3.68	3.85	3.80	3.54	3.71	3.64	3.42
47 x 220	4.71	4.56	4.15	4.49	4.39	3.99	4.31	4.23	3.85
50 x 122	2.19	2.17	2.12	2.12	2.10	2.04	2.06	2.04	1.97
50 x 147	2.83	2.81	2.73	2.73	2.70	2.61	2.65	2.61	2.51
50 x 170	3.45	3.41	3.28	3.31	3.27	3.15	3.20	3.15	3.01
50 x 195	4.14	4.09	3.76	3.96	3.90	3.61	3.81	3.74	3.49
50 x 220	4.83	4.65	4.23	4.61	4.47	4.07	4.42	4.32	3.93
63 x 97	1.77	1.75	1.72	1.72	1.71	1.66	1.68	1.66	1.61
63 x 122	2.44	2.42	2.36	2.36	2.34	2.27	2.30	2.27	2.18
63 x 147	3.15	3.12	3.03	3.03	2.99	2.89	2.93	2.89	2.77
63 x 170	3.82	3.78	3.54	3.66	3.61	3.41	3.53	3.47	3.29
63 x 195	4.56	4.45	4.06	4.36	4.29	3.90	4.19	4.11	3.77
63 x 220	5.19	5.00	4.56	5.00	4.82	4.39	4.84	4.66	4.24
75 x 122	2.64	2.62	2.56	2.56	2.53	2.45	2.48	2.45	2.36
75 x 147	3.40	3.36	3.25	3.27	3.23	3.11	3.16	3.11	2.98
75 x 170	4.11	4.07	3.75	3.94	3.88	3.61	3.79	3.73	3.49
75 x 195	4.79	4.70	4.29	4.67	4.53	4.13	4.49	4.38	3.99
75 x 220	5.48	5.28	4.83	4.28	5.09	4.65	5.11	4.93	4.49
38 x 140	2.32	2.30	2.25	2.25	2.22	2.16	2.19	2.16	2.08
38 x 184	3.39	3.35	3.24	3.25	3.21	3.09	3.14	3.09	2.95

Notes

- 1 The sizes spacings and spans given will support the dead loads stated in the table and imposed loads of 1.50 kN/m², or a concentrated load of 0.9 kN.
- 2 The section sizes are either regularised from BS 4471 basic sawn sizes in accordance with the tolerances and requirements of BS 4471 or CLS/ALS sizes with BS 4471 tolerances.
- 3 The minimum bearing length at supports for roof joists should be 35mm.
- 4 Notches and drilling of roof joists should not exceed the limit given in paragraph 1B6.

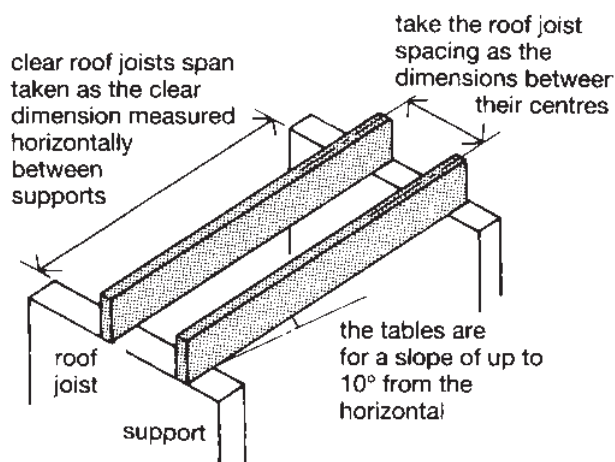

Table A15 Purlins supporting sheeting or decking for roofs having a pitch more than 10° but not more than 35°. Imposed loading 0.75 kN/m²

Maximum clear span of purlin(m) Timber of strength class SC3 and SC4 (see Table 1)

Size of purlin (mm x mm)	Dead Load [kN/m ²] excluding the self weight of the purlin																	
	Not more than 0.25						More than 0.25 but not more than 0.50						More than 0.50 but not more than 0.75					
	Spacing of purlins (mm)																	
	900	1200	1500	1800	2100	2400	900	1200	1500	1800	2100	2400	900	1200	1500	1800	2100	2400
50 x 100	1.68	1.63	1.51	1.42	1.34	1.28	1.55	1.48	1.40	1.31	1.24	1.18	1.45	1.37	1.31	1.22	1.16	1.10
50 x 125	2.24	2.03	1.88	1.77	1.67	1.60	2.06	1.88	1.74	1.63	1.54	1.47	1.91	1.77	1.63	1.53	1.44	1.37
50 x 150	2.68	2.44	2.26	2.12	2.01	1.19	2.49	2.26	2.09	1.96	1.85	1.76	2.34	2.12	1.96	1.83	1.73	1.65
50 x 175	3.12	2.84	2.63	2.47	2.34	2.23	2.90	2.63	2.43	2.28	2.16	2.06	2.72	2.47	2.28	2.13	2.02	1.92
50 x 200	3.56	3.24	3.00	2.82	2.67	2.55	3.31	3.00	2.78	2.60	2.46	2.35	3.11	2.81	2.60	2.44	2.30	2.19
50 x 225	4.00	3.63	3.37	3.17	3.00	2.86	3.71	3.37	3.12	2.93	2.77	2.64	3.49	3.16	2.92	2.74	2.59	2.47
63 x 100	1.87	1.77	1.64	1.54	1.46	1.39	1.72	1.64	1.51	1.42	1.34	1.28	1.60	1.52	1.42	1.33	1.26	1.20
63 x 125	2.42	2.20	2.04	1.92	1.82	1.73	2.25	2.04	1.89	1.77	1.68	1.60	2.10	1.91	1.77	1.66	1.57	1.50
63 x 150	2.90	2.63	2.44	2.30	2.18	2.08	2.69	2.44	2.26	2.12	2.01	1.92	2.53	2.29	2.12	2.00	1.88	1.79
63 x 175	3.37	3.07	2.85	2.67	2.54	2.42	3.13	2.84	2.63	2.47	2.34	2.23	2.94	2.67	2.47	2.32	2.19	2.09
63 x 200	3.84	3.50	3.25	3.05	2.89	2.76	3.57	3.24	3.01	2.82	2.67	2.55	3.36	3.05	2.82	2.65	2.51	2.39
63 x 225	4.31	3.92	3.64	3.43	3.25	3.10	4.01	3.64	3.38	3.17	3.01	2.87	3.77	3.42	3.17	2.97	2.82	2.68
50 x 100	1.70	1.71	1.58	1.48	1.40	1.34	1.64	1.57	1.46	1.37	1.30	1.23	1.53	1.45	1.37	1.28	1.21	1.15
50 x 125	2.34	2.13	1.97	1.85	1.75	1.67	2.17	1.97	1.82	1.71	1.62	1.54	2.02	1.85	1.71	1.60	1.51	1.44
50 x 150	2.80	2.55	2.36	2.22	2.10	2.00	2.60	2.36	2.18	2.05	1.94	1.85	2.44	2.21	2.05	1.92	1.81	1.73
50 x 175	3.26	2.97	2.75	2.58	2.45	2.34	3.03	2.75	2.54	2.39	2.26	2.15	2.85	2.58	2.39	2.24	2.12	2.01
50 x 200	3.72	3.38	3.14	2.95	2.79	2.67	3.45	3.13	2.90	2.73	2.58	2.46	3.25	2.94	2.72	2.55	2.42	2.30
50 x 225	4.17	3.80	3.53	3.31	3.14	3.00	3.88	3.52	3.26	3.06	2.90	2.77	3.65	3.31	3.06	2.87	2.72	2.59
63 x 100	1.99	1.84	1.71	1.61	1.52	1.45	1.81	1.71	1.58	1.49	1.41	1.34	1.69	1.60	1.48	1.39	1.32	1.26
63 x 125	2.53	2.30	2.13	2.00	1.90	1.81	2.35	2.13	1.97	1.85	1.76	1.68	2.21	2.00	1.85	1.74	1.65	1.57
63 x 150	3.02	2.75	2.55	2.40	2.28	2.17	2.81	2.55	2.37	2.22	2.10	2.01	2.64	2.40	2.22	2.08	1.97	1.88
63 x 175	3.52	3.20	2.97	2.80	2.65	2.53	3.27	2.97	2.76	2.59	2.45	2.34	3.08	2.79	2.59	2.43	2.30	2.19
63 x 200	4.01	3.65	3.39	3.19	3.03	2.89	3.73	3.39	3.14	2.95	2.80	2.67	3.51	3.19	2.95	2.77	2.62	2.50
63 x 225	4.49	4.10	3.81	3.58	3.40	3.25	4.18	3.80	3.53	3.32	3.15	3.00	3.94	3.58	3.32	3.11	2.95	2.81

Notes

- 1 The sizes spacings and spans given will support the dead loads stated in the table and imposed loads of 0.75 kN/m², measured on plan or a concentrated load of 0.9 kN.
- 2 The section sizes are either BS 4471 basic sawn sizes with the tolerances of BS 4471 or CLS/ALS sizes with BS 4471 tolerances.
- 3 The minimum bearing length at supports for purlins should be 50mm.
- 4 No notches or holes should be cut in purlins unless checked by a competent person.

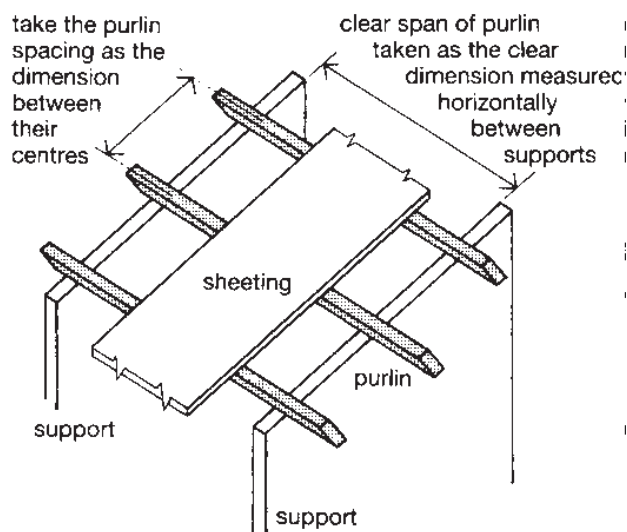

Standards referred to

BS 12: 1989 *Specification for Portland cements.*

BS 187: 1978 *Specification for calcium silicate (sandlime and flintlime) bricks*

Amendment slip
1: AMD 5427

BS 449: *Specification for the use of structural steel in building:*

Part 2: 1969 *Metric units*

Amendment slips

1: AMD 416,
2: AMD 523,
3: AMD 661,
4: AMD 1135,
5: AMD 1787,
6: AMD 4576,
7: AMD 5698,
8: AMD 6255.

BS 882: 1983 *Specification for aggregates from natural sources for concrete*

Amendment slip
1: AMD 5150.

BS 1243: 1978 *Specification for metal ties for cavity wall construction*

Amendment slips
1: AMD 3651,
2: AMD 4024.

BS 1297: 1987 *Specification for tongued and grooved softwood flooring.*

BS 3921: 1987 *Specification for clay bricks.*

BS 4471: 1987 *Specification for sizes of sawn and processed softwood.*

BS 4978: 1988 *Specification for softwood grades for structural use.*

BS 5268: *Structural use of timber:*

Part 2: 1991 *Code of practice for permissible stress design, materials and workmanship.*

Part 3: 1985 *Code of practice for trussed rafter roofs*

Amendment slip

1: AMD 5931

Part 6: *Code of practice for timber framed walls.*

Section 6.1: 1988 *Dwellings not exceeding three storeys.*

BS 5328: *Concrete:*

Part 1: 1991 *Guide to specifying concrete*

Part 2: 1991 *Methods for specifying concrete mixes*

BS 5390: 1976 *Code of practice for stone masonry,*

Amendment slip
1: AMD 4272

BS 5628: *Code of practice for use of masonry:*
Part 1: 1978 *Structural use of unreinforced masonry*

Amendment slips

1: AMD 2747,
2: AMD 3445,
3: AMD 4800,
4: AMD 5736.

Part 3: 1985 *Materials and components, design and workmanship*

Amendment slip

1: AMD 4974.

BS 5950: *Structural use of steelwork in buildings:*

Part 1: 1990 *Code of practice for design in simple and continuous construction: hot rolled sections.*

Part 2: 1992 *Specification for materials, fabrication and erection: hot rolled sections.*

Part 3: *Design in composite construction:*

Section 3.1: 1990 *Code of practice for design of simple and continuous composite beams.*

Part 4: 1982 *Code of practice for design of floors with profiled steel sheeting.*

Part 5: 1987 *Code of practice for design of cold rolled sections.*

Amendment slip

1: AMD 5957.

BS 6073: *Precast concrete masonry units*

Part 1: 1981 *Specification for precast concrete masonry units*

Amendment slips

1: AMD 3944,
2: AMD 4462.

BS 6399: *Loading for buildings:*

Part 1: 1984 *Code of practice for dead and imposed loads*

Amendment slips

1: AMD 4949,
2: AMD 5881,
3: AMD 6031.

Part 3: 1988 *Code of practice for imposed roof loads*

Amendment slip

1: AMD 6033.

BS 6649: 1985 *Specification for clay and calcium silicate modular bricks.*

BS 6750: 1986 *Specification for modular co-ordination in building.*

BS 8004: 1986 *Code of practice for foundations.*

BS 8110: Structural use of concrete,
Part 1: 1985 *Code of practice for design and construction*

1: AMD 5917,
2: AMD 6276.

Part 2: 1985 *Code of practice for special circumstances*

Amendment slip

1: AMD 5914

Part 3: 1985 *Design charts for single reinforced beams, doubly reinforced beams and rectangular columns*

Amendment slip

1: AMD 5918.

BS 8200: 1985 *Code of practice for design of non-loadbearing external vertical enclosure of buildings.*

BS 8298: 1989 *Code of practice for design and installation of natural stone cladding and lining.*

CP3: Chapter V: *Loading:*

Part 2: 1972 *Wind loads*

Amendment slips

1: AMD 4952,
2: AMD 5152,
3: AMD 5343,
4: AMD 6028.

CP 118: 1969 *The structural use of aluminium.*

Amendment slip

1: AMD 1129.

BS 5628: *Code of practice for use of masonry:*

Part 1: 1978 Structural use of unreinforced masonry

Amendment slips

1: AMD 2747,
2: AMD 3445,
3: AMD 4800,
4: AMD 5736.

BS 5950: *Structural use of steelwork in building:*

Part 1: 1990 Code of practice for design in simple and continuous construction; hot rolled sections.

BS 8110: *Structural use of concrete:*

Part 1: 1985 *Code of practice for design and construction,*

Amendment slips

1: AMD 5917,
2: AMD 6276.

Part 2: 1985 *Code of practice for special circumstances*

Amendment slip

1: AMD 5914.

Lists of codes of practice currently issued or approved by the Planning and Environment Committee for the purpose of showing compliance with the Building Bye-Laws (Jersey) 1997.

- Technical Guidance Document. Part 1 Structure
- Technical Guidance Document. Part 2 Fire Safety
- Technical Guidance Document. Part 3 Heat Producing Appliances and Storage of Fuels
- Technical Guidance Document. Part 4 Site Preparation and Resistance to Moisture
- Technical Guidance Document. Part 5 Ventilation
- Technical Guidance Document. Part 6 Drainage, Hygiene and Water Storage
- Technical Guidance Document. Part 7 Stairs, Ramps and Protective Barriers
- Technical Guidance Document. Part 8 Access and Facilities for Disabled People
- Technical Guidance Document. Part 9 Resistance to the Transmission of Sound
- Technical Guidance Document. Part 10 Glazing—Safety and Protection
- Technical Guidance Document. Part 11 Conservation of Fuel and Power
- Technical Guidance Document. Supporting Bye-Law 7. Materials and Workmanship